

SMOKE STOPPER

INTRODUCTION

> To answer the growing demand for a safe working environment, **REFLEX™** has incorporated the **SMOKE STOPPER** smoke containment product into the already extensive range of **REFLEX™** automated, environmental control blinds and screens.

APPLICATION

> In the design of public buildings and other highly populated defined spaces where there is any possibility of the threat of smoke or fume generation, consideration must be given to the safe escape of the occupants. To be able to automatically contain or redirect the flow of fumes or smoke within a confined area is the purpose of the **REFLEX™ SMOKE STOPPER**. Designed to be permanently hidden within the ceiling cavity of any given thoroughfare and to be activated in concert with electronic fire warning systems, the flame proof screen will automatically lower to a predetermined height above FFL to allow the egress of occupants while stopping the progress of smoke spread to that area.

SPECIFICATION

> The **REFLEX™ SMOKE STOPPER** is an electrically operated roller screen, sealed within a heavy steel cassette which is installed within ceiling cavities in conjunction with a cavity smoke sealing system. When activated, by the fire management system, a flame proof, textile screen will lower to either one of the two possible preset positions.

The casing of the cassette shall be 2 mm mild steel with Galvabond coating. Casing dimensions are 165 mm wide and 180 mm high. End plates of the cassette shall be 8 mm thick mild steel with blue zinc plated finish to prevent corrosion. These end plates also serve as mounting points for the internal fabric storage roller and drive motor.

Maximum span for a single cassette is 5,000 mm.

Mounting cross bars shall be spaced at approximately 2,000 mm centres and 500 mm from each end of the cassette.

Approximate weight of the complete system is 25 kgs/metre.

When the blinds are mounted abutting a vertical wall, side edge guides are available as an option to complete the total smoke seal to the three sides (top, left and right).

The flame proof fabric shall be a continuous filament, fibreglass based, sealed woven cloth with zero particle penetration. Colour shall be silver grey to both sides.

Fabric thickness shall be 0.46 mm (nominal) and weight is 0.543 gsm (nominal). The fabric shall be stored when not in use by axial rotation onto the 127 mm aluminium roller. This roller shall be made from 6106 T6 extruded aluminium and is in one piece. Fabric shall be fixed to the roller both chemically and mechanically. The fabric hem rail shall be extruded, natural anodised aluminium in a profile to suit.

An internal asynchronous digitally controlled AC motor shall drive the fabric storage roller in each individual system and lower the screen at approximately 8 seconds per metre when commanded by the management system via dry contactors for extend/stop/retract control.

The circuitry allows for three predetermined hem positions

- Fully retracted which may be the ceiling level or fully retracted into the cassette,
- Intermediate – which may be used as “egress height” or evacuation level (900 mm above F.F.L).
- Fully extended – which would be to floor level as required.

Control wiring shall be four core flat cable and RJ11 phone type connectors. Multiple blinds can be wired in series or parallel with no extra control components.

Standard 240 volt power should be supplied to each screen by incorporating a UPS within the supply circuit. (Specifications available separately, are dependent on individual installations and control systems).

Minimum width	=	1,000 mm
Maximum width	=	5,000 mm
Minimum drop	=	500 mm
Maximum drop	=	5,000 mm



SMOKE STOPPER

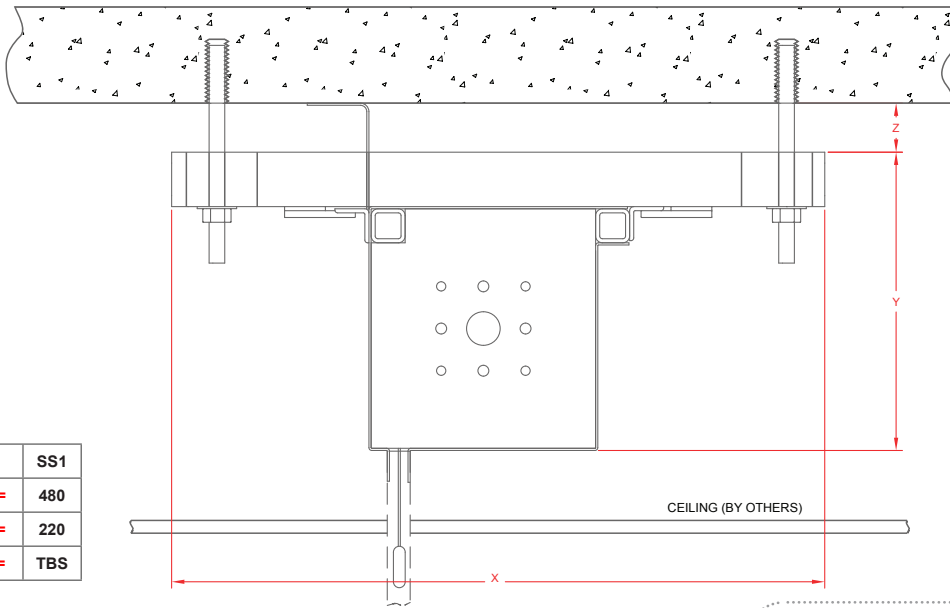

	SS1
X =	480
Y =	220
Z =	TBS

PROFILE

SMOKE STOPPER EXPLODED

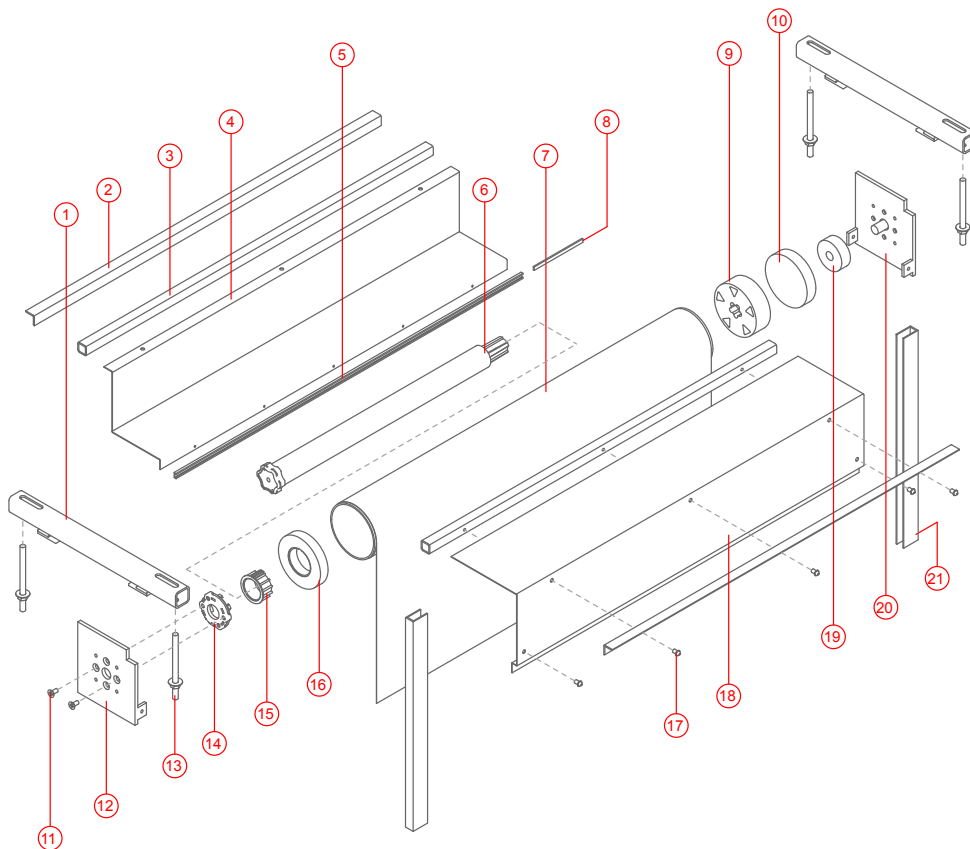

ITEM	DESCRIPTION
1.	MOUNT BAR
2.	ANGLED BAR
3.	HOLLOW BAR
4.	COVER - BACK
5.	FELT STRIP CHANNEL
6.	MOTOR
7.	ROLLER TUBE WITH FABRIC
8.	FELT STRIP
9.	MOTOR WHEEL
10.	BEARING PLATE
11.	MOTOR ADAPTOR SCREW
12.	END PLATE - LHS
13.	MOUNTING ROD
14.	MOTOR ADAPTOR
15.	MOTOR CROWN INSERT
16.	MOTOR CROWN
17.	COVER FIXING SCREW
18.	COVER - FRONT
19.	BEARING
20.	END PLATE - RHS
21.	SIDE GUIDE