



C-Bus 2 Channel Bus Coupler with Remote LED Facility Installation Instructions

5102BCLEDL

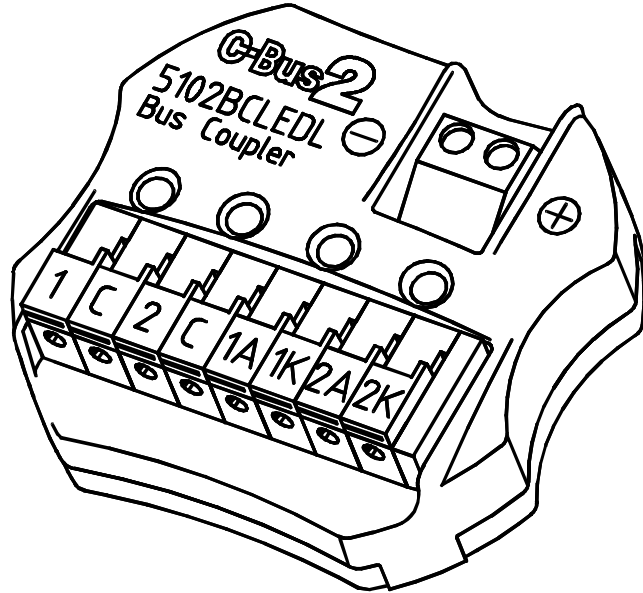

Table of Contents

Section.....	Page
1.0 Product Range	3
2.0 Description	3
3.0 Capabilities	3
4.0 Wiring Instructions.....	4
4.1 Connection to the C-Bus Network.....	5
4.2 Connection to Remote Switches and LEDs	6
4.3 Programming Requirements	7
5.0 Power Surges and Short Circuit Conditions	8
6.0 Megger Testing	8
7.0 Important Warning.....	8
8.0 Standards Complied.....	9
9.0 Product Specifications.....	10

Copyright Notice

© Copyright 2004 Clipsal Integrated Systems Pty Ltd. All rights reserved.

Trademarks

- Clipsal is a registered trademark of Clipsal Australia Pty Ltd.
 - C-Bus and C-Bus2 are registered trademarks of Clipsal Integrated Systems Pty Ltd.
 - Intelligent Building Series is a registered trademark of Clipsal Integrated Systems Pty Ltd.
- All other logos and trademarks are the property of their respective owners.

Disclaimer

Clipsal Integrated Systems reserves the right to change specifications or designs described in this manual without notice and without obligation.

1.0 Product Range

5102BCLEDL C-Bus Two Channel Bus Coupler with Remote LED's

2.0 Description

The Two Channel Bus Coupler unit is a Key Input device allowing connection of voltage free mechanical switches into the C-Bus system. It offers the facility to connect external LED indicators via flying leads. The Learn Mode feature is also incorporated in this device, allowing a quick and easy way to program mechanical switches, to achieve various control functions such as: on/off, dimmer or timer.

3.0 Capabilities

The Two Channel Bus Coupler facilitates remote access to C-Bus via any voltage free switch mechanism, such as the Clipsal 30M range. In this way the user can mix and match 2000 Series, Standard Range, Heritage Range, Metal Plate or Prestige Series style switch plates and products with C-Bus. Alternatively, reed, pressure, micro or other switches may be used to enhance the system flexibility.

The Two Channel Bus Coupler is designed to use external LED's to indicate the condition of the being operated. These are connected to the unit via flying leads.

Being an input device, the unit transmits messages to output devices to control load states. All C-Bus switching commands are available, including: on, off, toggle, timer and dimming functions etc. **Dimming operations are best achieved using a spring return type switch such as the Clipsal 30MBPR Bell Press mechanism.**

The Two Channel Bus Coupler consumes 18mA of current and is counted as one C-Bus unit when considering the number of units connected to a Power Supply on the Network.

4.0 Wiring Instructions

WARNING: The two channel inputs of the Bus Coupler are NOT isolated from the C-Bus Network. Take extra care when installing these devices ensuring all cables connected to C-Bus are well separated from mains. External switches must not be referenced to any other voltage source.

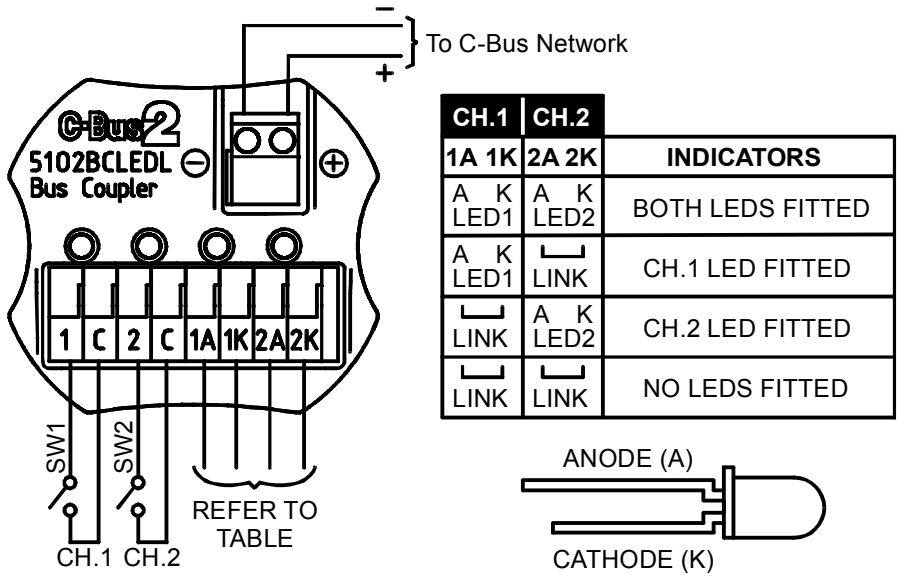

IMPORTANT – The LED output connections must be made and maintained correctly for the unit to operate. **The factory fitted wire link should only be removed if an LED connection is to be made.**

- **Flashing LED's are not compatible with this product.**

To minimise the amount of wire required (see section 4.2) a single common wire may be used as shown in the diagram below.

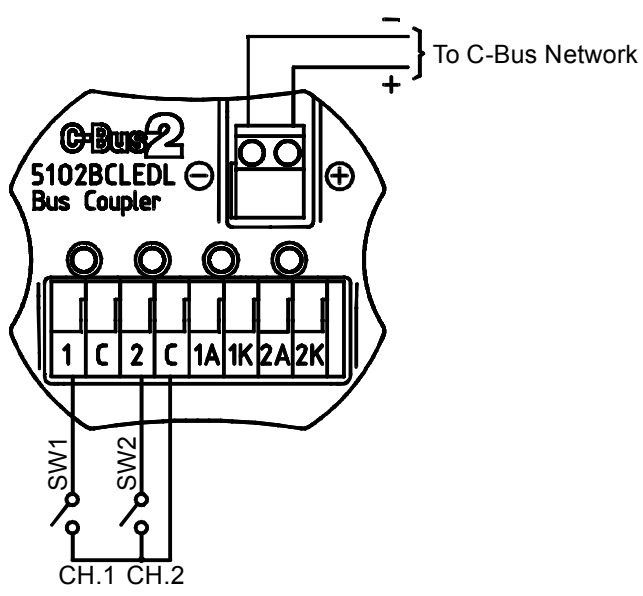

4.1 Connection to the C-Bus Network

Installation of the Two Channel Bus Coupler requires connection to the unshielded twisted pair C-Bus Network Cable. Connection should be made using Category 5 data cable, catalogue number 5005C305B.

The C-Bus Network Connection is polarity sensitive, and is clearly marked on the unit. One loop-in removable terminal block is provided for easy installation and maintenance. Ensure that correct colour coding (as shown below) is adhered to for trouble free operation.

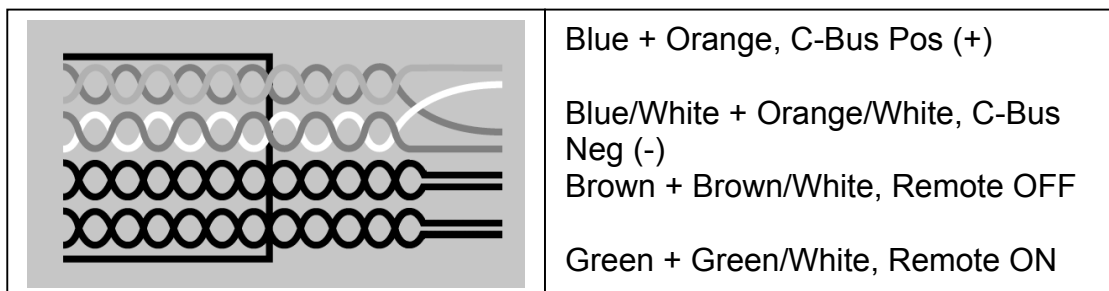
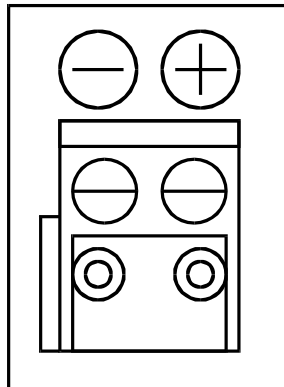

C-Bus Connection	Colour	Bus Coupler
Remote ON*	Green/White	Not Connected
Remote ON	Green	Not Connected
C-Bus Neg (-)	Orange/White	C-Bus Neg (-)
C-Bus Pos (+)	Blue	C-Bus Pos (+)
C-Bus Neg (-)	Blue/White	C-Bus Neg (-)
C-Bus Pos (+)	Orange	C-Bus Pos (+)
Remote OFF	Brown/White	Not Connected
Remote OFF	Brown	Not Connected

* The Two Channel Bus Coupler does not have Remote Override (On/Off) functions, however correct connections must be maintained for these services across the C-Bus Network.

4.2 Connection to Remote Switches and LEDs

The C-Bus Bus Coupler with remote LED feedback enables the use of a wide range of conventional dry contact switch mechanisms, chosen on the basis of appearance, to indirectly switch C-Bus loads. The C-Bus Bus Coupler is designed to fit within the wall box behind switches. A small length of wire is used to connect these switches and remote LED's to the inputs and outputs of the C-Bus Bus Coupler.

Insulated wire¹ with a diameter no greater than 2mm may be used to connect the voltage free switches and remote LED's to the Bus Coupler terminals. The maximum cable length is 1 metre per channel/LED output, however the total length of cable connecting the remote switches and LED's to C-Bus Bus Couplers in a single network should be kept to 10 metres for good communications in a C-Bus system. (i.e. 5 channels, 5 LED's at 1m or 10 channels, 10 LED's at 500mm etc)

If longer connections are required the 5104AUX or L5504AUX, which have input isolation, should be used as these units are specifically designed for such an application but do not offer remote LED indication.

In all cases, switch input and LED connection wires should be segregated from mains wiring, any electrical noise sources and earthed metal structures in accordance with C-Bus wiring rules.

If one or both LEDs are not being fitted, the unused LED output(s) must be shorted by link wire to maintain a connection. In order to facilitate off-site operation and programming without the need to fit LEDs, the unit is supplied with wire links fitted.

IMPORTANT – The LED output connections must be made and maintained as shown in the previous wiring diagram for the unit to operate.

Spring Loaded Terminal	Description
1	Channel 1 Input
C	Switched Input Common ²
2	Channel 2 Input
C	Switched Input Common ²
1A	LED 1 Anode
1K	LED 1 Cathode ³
2A	LED 2 Anode ³
2K	LED 2 Cathode

¹ Insulated cables must be of a type conforming to requirements of the ACA Telecommunications labelling notice.

² The switched input Common is internally connected to C-Bus negative.

³ The 1K and 2A outputs are linked internally.

4.3 Programming Requirements

The installer can program the unit in two ways, with the computer or using Learn mode. Whichever method is used, the Two Channel Bus Coupler must be assigned a unique unit address and a group address for each of the two channels.

4.3.1 Programming with a Personal Computer

The latest C-Bus Service Pack is available for download from the Clipsal Integrated System's Web Site (www.clipsal.com/cis). This is available on the 'Downloads' page along with other C-Bus products.

For further information about programming this and other C-Bus units, please refer to the C-Bus Technical Manual (5000S/2, 5000M/2).

4.3.2 Programming without a Personal Computer using Learn Mode

The Two Channel Bus Coupler is a C-Bus2 Input device, which allows users to set the relationships between Output Units and the Input Unit without a computer.

Note: Each output unit which is to be associated with the Two Channel Bus Coupler in this way must be a C-Bus2 unit as well.

Learn Mode provides a quick and simple way to program the C-Bus2 Input devices to provide basic functions. If more advanced functions are required see section 5.1 above.

To program the Two Channel Bus Coupler to turn on loads by means of Learn Mode connect each channel of the Two Channel Bus Coupler to a conventional switch. Then do the following for each channel:

- Enter Learn Mode on a C-Bus2 output unit by holding down a toggle key on that unit for 10 seconds until the Unit and C-Bus indicators flash alternately.
- Select the toggle keys on the output unit associated with the loads you want to control. The selected indicators will illuminate.
- Flick the (non C-Bus) toggle switch you want to associate with the selected load on. The light on the Bus Coupler associated with this switch will light.
- Exit Learn Mode by pressing any toggle switch on an output unit for 2 seconds.

5.0 Power Surges and Short Circuit Conditions

The mains voltage must be limited to the range specified for any unit that is mains powered. Each unit incorporates transient protection circuitry and additional external power surge protection devices should be used to enhance system immunity to power surges. It is strongly recommended that over-voltage equipment such as the Clipsal 970 series is installed at the switchboard.

6.0 Megger Testing

Megger testing of mains cabling of an electrical installation that has C-Bus units connected will not cause any damage to C-Bus units. Since C-Bus units contain electronic components, the installer should interpret megger readings with due regard to the nature of the circuit connection.

Megger testing must never be performed on the C-Bus data cabling or Bus Coupler input terminals as it may degrade the performance of the network.

7.0 Important Warning

The use of any non C-Bus Software in conjunction with the hardware installation without the written consent of Clipsal Integrated Systems may void any warranties applicable to the hardware.

8.0 Standards Complied

DECLARATIONS OF CONFORMITY

European Directives and Standards

Model 5102BCLEDL complies with the following:



European Council Directive		Standards	Title
89/336/EEC	EMC Directive	EN 55014-1; IEC/CISPR 14-1 EN61000-3-2; IEC61000-3-2 EN60669-2-1; IEC 60669-2-1 BS/EN 61000-4-2 BS/EN 61000-4-3 BS/EN 61000-4-4 BS/EN 61000-4-5 BS/EN 61000-4-11	RFI Emissions Standard RFI Emissions Standard RFI Emissions Standard Immunity to ESD Immunity to RFI Immunity to EFT Immunity to Surge Voltages Immunity to Voltage Dips & Interruptions

Australian/New Zealand EMC Framework and Standards

Model 5102BCLEDL complies with the following:



C-Tick Framework	Standards	Title
EMC	AS1044; IEC/CISPR14-1 AS/NZS61000.3.2; EN61000-3-2; IEC61000-3-2	RFI Emissions Standard RFI Emissions Standard

U.S. FCC Regulations

Model 5102BCLEDL complies with the following:



Standards/Regulations	Title
FCC	Part 15, Class B Digital Device for Home or Office Use

Supplemental Information

This device complies with part 15 of the FCC Rules. Operation is subject to the following two conditions: (1) this device may not cause harmful interference, and (2) this device must accept any interference received, including interference that may cause undesirable operation

Class B Product

NOTE:

This equipment has been tested and found to comply with the limits for a Class B digital device, pursuant to Part 15 of the FCC Rules. These limits are designed to provide reasonable protection against harmful interference in a residential installation. This equipment generates, uses and can radiate radio frequency energy and, if not installed and used in accordance with the instructions, may cause harmful interference to radio communications. However, there is no guarantee that interference will not occur in a particular installation. If this equipment does cause harmful interference to radio or television reception, which can be determined by turning the equipment off and on, the user is encourage to try to correct the interference by one or more of the following measures:

- Reorient or relocate the receiving antenna
- Increase the separation between the equipment and receiver
- Connect the equipment into an outlet on a circuit different from that to which the receiver is connected
- Consult the dealer or an experienced radio/TV technician for help

Warning: Any changes or modifications not expressly approved by Clipsal Integrated Systems could void the user's authority to operate this equipment.

9.0 Product Specifications

Parameter	Description
Catalogue Number	5102BCLEDL Two Channel Bus Coupler with Remote LED's
C-Bus Supply Voltage	15-36V DC @ 18mA required for normal operation depending on LED output configuration (See table below for minimum operating voltages). Does not source current to the C-Bus Network.
Current Drain	18 mA
Voltage across Input when external switch opens	5V DC
Voltage across Input when external switch closes	0V DC
Switch closed current	Less than 50µA
Max cabling distance	1m
Isolation between inputs	Not isolated
Isolation between inputs and C-Bus	Not isolated
Operating Temperature	0 – 45°C
Operating Humidity Range	10-95% RH
C-Bus Terminals	Removable terminals for wire size 0.2 – 1.5 mm ²
Two Channel Input/Output Side	Spring loaded terminals for wire size 0.2 – 2.5mm ²
Weight	32g
Dimensions	55 x 49 x 18mm (L x W x D)

Minimum C-Bus operating voltage specifications

LED output configuration	Minimum C-Bus operating voltage
Using two LEDs	15V + Sum of both LED forward voltages
Using one LED and one link	15V + LED forward voltage
Using no LEDs and two links	15V

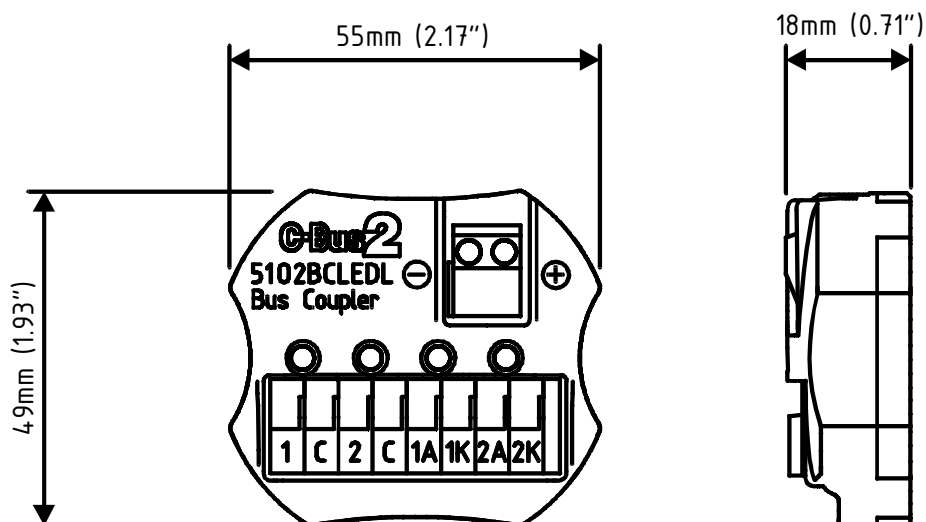

No user serviceable parts inside.

Further Information

For further information about configuring this product and other C-Bus devices, please consult the documentation supplied. Further assistance can be obtained as follows:

- **C-Bus Manuals**

The 5000M/2 C-Bus Technical Manual provides a comprehensive and definitive guide to Clipsal C-Bus. Includes hardware and software specifications, product datasheets, system design and installation guides, and software overview with fully worked programming examples.

- **C-Bus Installation Software**

The 5000S/2 C-Bus Installation Software (includes 5000M/2 C-Bus Technical Manual) may be used to unlock the power and flexibility of Clipsal C-Bus. Unit operation may be completely customised to suit user requirements. Advanced control functions may be programmed.

- **C-Bus Installer Training Courses**

Contact your nearest Clipsal Integrated Systems Sales or Technical Support Officer and enquire about Clipsal C-Bus Installer Training and Certification Programs today.

- **Technical Support and Troubleshooting**

For further assistance, please consult your nearest Clipsal Integrated Systems Sales Representative or Technical Support Officer.

Technical Support Hotline

1 300 722 247

(Cost 25¢ per call, Australia Only)

Technical Support Email

techsupport.cis@clipsal.com.au

Sales Support Email

sales.cis@clipsal.com.au

Clipsal Integrated Systems Website

clipsal.com/cis

Products of Clipsal Integrated Systems Pty Ltd

ABN 15 089 444 931

Head Office

12 Park Terrace, Bowden

South Australia 5007

International Phone +61 8 8440 0500

International Fax +61 8 8346 0845

Internet clipsal.com/cis

E-Mail cis@clipsal.com.au

1036494