

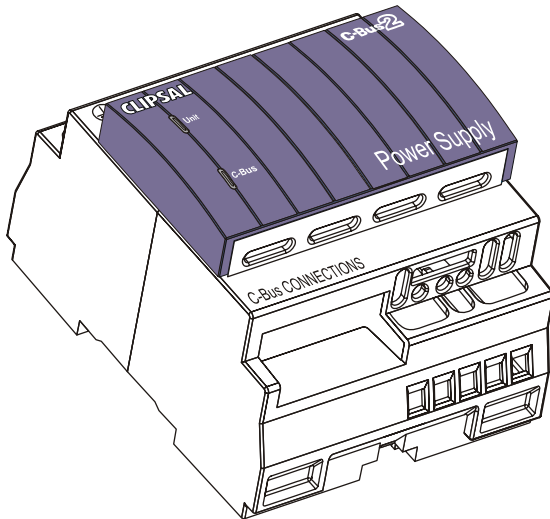

C-Bus DIN Rail Power Supply, 350 mA

Installation Instructions

5500PS Series



© Copyright Clipsal Integrated Systems Pty Ltd 2005. All rights reserved. This material is copyright under Australian and international laws. Except as permitted under the relevant law, no part of this work may be reproduced by any process without prior written permission of and acknowledgement to Clipsal Integrated Systems Pty Ltd.

Clipsal is a registered trademark of Clipsal Australia Pty Ltd.

The information in this manual is provided in good faith. Whilst Clipsal Integrated Systems (CIS) has endeavoured to ensure the relevance and accuracy of the information, it assumes no responsibility for any loss incurred as a result of its use. CIS does not warrant that the information is fit for any particular purpose, nor does it endorse its use in applications which are critical to the health or life of any human being. CIS reserves the right to update the information at any time without notice.

V2.0 July 2005

Contents

1.0	Product Range	5
2.0	Description	5
	2.1 Why Use a C-Bus Power Supply?	5
3.0	Installation Considerations	6
4.0	Wiring Instructions	6
5.0	C-Bus Network Connection	7
6.0	Status Indicators	9
	6.1 C-Bus Indicator	9
	6.2 Unit Indicator	9
7.0	Output Current Limiting	10
8.0	Power Surges and Short Circuit Conditions	10
9.0	Megger Testing	11
10.0	Programming	11
11.0	Electrical Specifications	12
12.0	Mechanical Specifications	13
13.0	Standards Complied	14
14.0	Warranty	15

1.0 Product Range

5500PS C-Bus DIN Rail Power Supply, 350 mA (220 to 240 V)

E5500TPS C-Bus DIN Rail Power Supply, 350 mA (110 to 120 V)

2.0 Description

The 5500PS Series C-Bus Power Supply provides up to 350 mA to a C-Bus network, at up to 36 V DC. This is sufficient to power approximately 15×22 mA C-Bus units such as Neo and Ulti Saturn switch plates. The unit is DIN rail mounted, measuring 4 modules wide (1 module = 17.5 mm). C-Bus connection is achieved through the use of RJ45 connectors, allowing similar units to be quickly looped together.

2.1 Why Use a C-Bus Power Supply?

The C-Bus Power Supply is designed to have a defined value DC output resistance, and at the same time present a high AC impedance at C-Bus communication frequencies (500 to 5000 Hertz). For this reason, standard off the shelf power supplies are not suitable for use with a C-Bus network.

3.0 Installation Considerations

A maximum total current of 2 Amps may be supplied to a C-Bus network. This is due to power dissipation limitations of the cable. It means that up to five 5500PS Series units may be connected to an individual C-Bus network if no other C-Bus power supplies are connected. Some C-Bus units such as the L5508D1A Dimmer and the L5508RVF Voltage Free Relay, have built-in power supplies. These must be taken into account when determining the total current available.

To minimise voltage drop due to cable resistance, Power Supplies should be distributed evenly along a C-Bus network. The minimum operating voltage of any C-Bus unit on the network is 15 V DC. To achieve the most efficient installation, it is recommended that the maximum voltage drop between a C-Bus unit and the closest power supply is limited to 10 volts. For simplicity, it can be assumed that the Cat-5 C-Bus cable resistance is 1 ohm per 10 metres. The DC output resistance characteristic of the 5500PS Series ensures that the load is shared relatively evenly between multiple Power Supplies.

4.0 Wiring Instructions

A wiring diagram for the 5500PS Series Power Supply is provided in Figure 1. Consider the following points when installing the unit:

- An individual C-Bus network must not be supplied with more than 2 Amps total current.
- Fix mains cabling in the distribution board using cable ties or trunking as required by local wiring rules. Take care not to allow copper strands to enter the DIN unit's apertures.
- Apply a maximum torque of 1.4 Nm to the mains rated screw terminals.
- Rubber bungs are supplied for unused RJ45 connectors, to stop foreign bodies from entering the unit. Always install these bungs when the unit is mounted inside a mains rated enclosure.
- Use copper wire only.

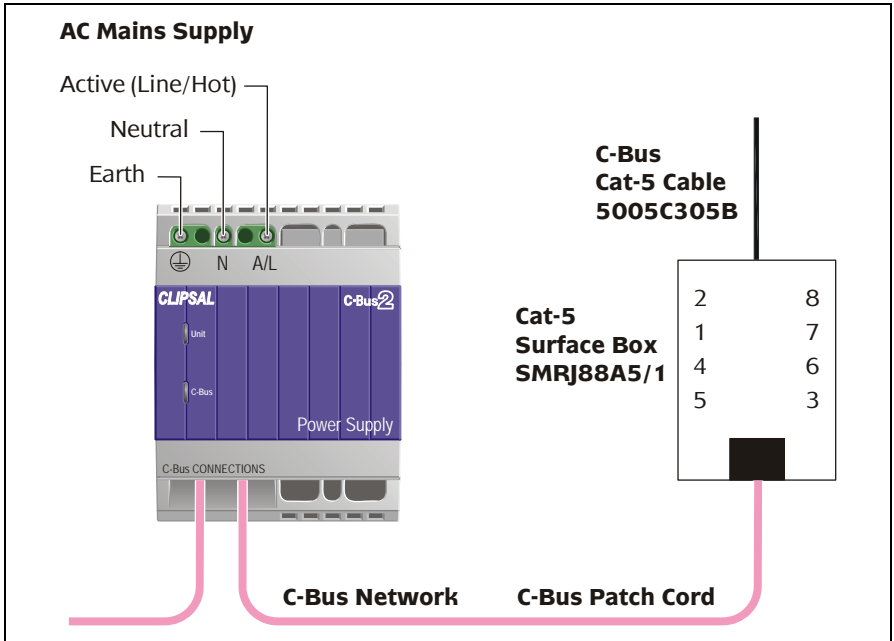

Figure 1 – 5500PS Series wiring

5.0 C-Bus Network Connection

Connection to the C-Bus network is made via one of the RJ45 sockets. Use Cat-5 Unshielded Twisted Pair (UTP) C-Bus cable, and an appropriately wired RJ45 plug. Pinouts and cable conductor assignments are provided in Figure 2 and Table 1. The RJ45 sockets are internally connected. The Clipsal catalogue number for the C-Bus Cat-5 UTP cable is 5005C305B.

It is recommended that the Remote Override (On/Off) connections be maintained for correct operation of these services across the C-Bus network, even if they are not intended to be used.

A Clipsal RJ5CB300PL Cat-5 UTP patch cord is included with the unit for easy interconnection. No more than 5 × 5500PS Series products should be connected to one physical C-Bus network.

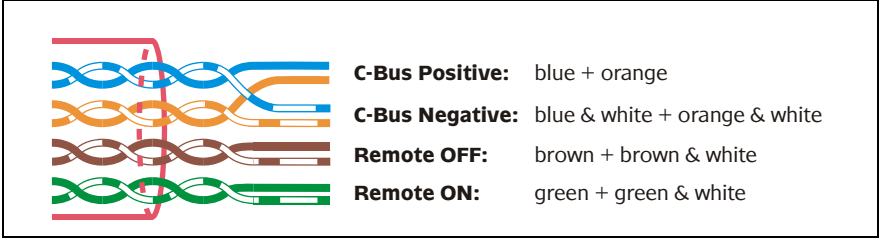

Figure 2 – C-Bus cable conductor assignments

Pin	C-Bus Connection	Colour
1	Remote ON	green & white
2	Remote ON	green
3	C-Bus Negative (-)	orange & white
4	C-Bus Positive (+)	blue
5	C-Bus Negative (-)	blue & white
6	C-Bus Positive (+)	orange
7	Remote OFF	brown & white
8	Remote OFF	brown

Table 1 – RJ45 sockets and C-Bus pinouts

6.0 Status Indicators

6.1 C-Bus Indicator

The “C-Bus” indicator shows the status of the C-Bus network at the unit. If sufficient network voltage is present, the indicator illuminates (as a continuous green light). If a network is connected which has a higher current load than the power supplies support, the indicator flashes to show a marginal network voltage.

Indicator Status	Meaning
On	Power is on and functional
Flashing	The network voltage is marginal (15 V < voltage < 20 V)
Off	Mains power is not connected or C-Bus voltage is below 15 V

Table 2 – The “C-Bus” indicator

6.2 Unit Indicator

The “Unit” indicator shows the status of the individual unit. When mains power is supplied, the indicator illuminates (as a continuous green light).

Indicator Status	Meaning
On	Normal operation
Off	No mains power is connected

Table 3 – The “Unit” indicator

7.0 Output Current Limiting

One of the advantages of the low C-Bus DC operating voltage, is that connections can be made whilst the network is powered up. Should a short circuit occur, the Power Supply's output current limiting / overload circuitry protects it from damage for an indefinite period of time. The Power Supply's defined output resistance and current limiting characteristic is illustrated in Figure 3.

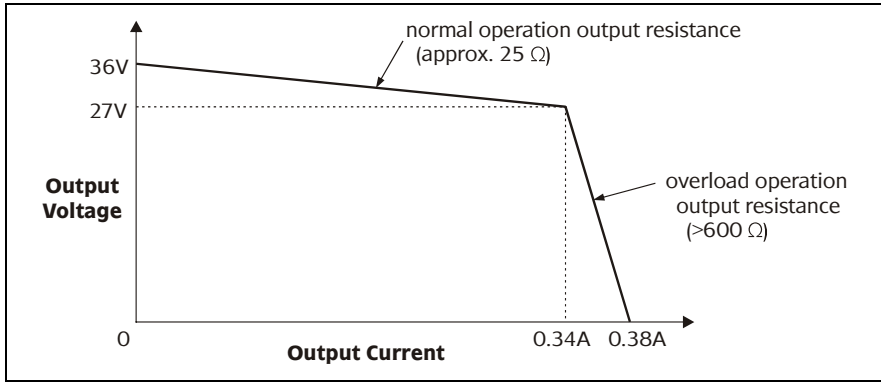

Figure 3 – Output voltage vs output current

8.0 Power Surges and Short Circuit Conditions

External power surge protection devices should be used to enhance system immunity to mains voltage surges. It is recommended that overvoltage equipment such as the Clipsal 970RMT be installed at the switchboard.

The C-Bus Power Supply output includes protection against short circuits and electrical overload. The unit electronically isolates mains power from the C-Bus network.

9.0 Megger Testing

Megger testing must never be performed on the C-Bus data cabling or terminals as it could degrade the performance of the network.

Megger testing of a mains electrical installation that has C-Bus units connected will not damage the units. Since C-Bus units contain electronic components, this should be taken into account when interpreting megger readings.

10.0 Programming

Unlike other C-Bus units, the 5500PS Series Power Supply does not require programming.

11.0 Electrical Specifications

Parameter	Description	
	5500PS	E5500TPS
Nominal supply voltage	220 to 240 V AC	110 to 120 V AC
Frequency range	47 to 63 Hz	
C-Bus output voltage	36 V DC maximum	
C-Bus output current	≤ 350 mA	
Output short circuit current	< 400 mA	
DC output resistance	25 Ω (approx.)	
C-Bus AC output impedance	> 60 k Ω @ 1 kHz	
Electrical isolation	3.75 kV RMS from C-Bus to mains	
Maximum units per C-Bus network	5	
Power supply type	Electronic transformer with high output impedance	
Quiescent power	15 W maximum	
Warm up time	3 seconds	
Operating temperature	0 to 45 °C (32 to 113 °F)	
Operating humidity	10 to 95% RH	

12.0 Mechanical Specifications

Parameter	Description
Dimensions (W×H×D)	72 × 92 × 63 mm (2.83 × 3.62 × 2.48 inches)
Weight	190 g (6.7 oz)
Mains terminals	Accommodates 2 × 1.5 mm ² or 1 × 2.5 mm ² (2 × 16 AWG or 1 × 13 AWG)
C-Bus connections	2 × RJ45 sockets (in parallel)

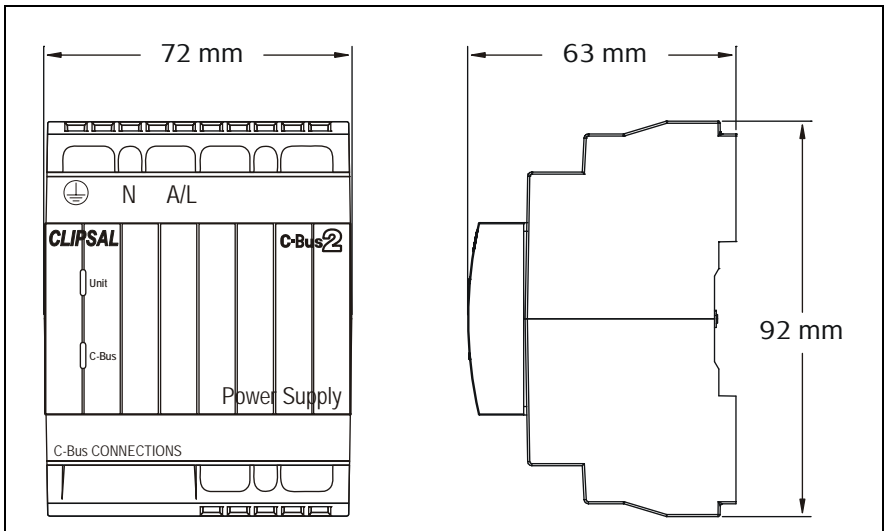

13.0 Standards Complied

Australian/New Zealand EMC & Electrical Safety Frameworks and Standards

The 5500PS product complies with the following:



Regulation	Standard	Title
Electrical Safety	AS/NZS 3100	General Requirements for Electrical Equipment
	AS/NZS 3108	Requirements for Safety Extra Low Voltage
EMC (C-Tick)	IEC61204-3	LV Power Supplies (Emissions)

European Directives and Standards

The 5500PS product complies with the following:



European Council Directive	Standard	Title
EMC Directive 89/336/EEC	EN61000-3-2, EN61000-3-3 EN61204-3	EMC LF Standard LV Power Supplies (Emissions & Immunity)
Low Voltage Directive 73/23/EEC	EN 61558-1, EN61558-2-17	Safety of Power Supplies & Transformers

US and Canadian Product Safety Standards and US FCC Regulations

The E5500TPS product complies with the following:



Standard/Regulation	Title
CSA C22.2 No. 107.1 UL1012	General Use Power Supplies Power Units Other Than Class 2
Tested to FCC Standards for Home or Office Use	FCC Part 15 ANSI C63.4



Supplemental Information

This device complies with part 15 of the FCC Rules. Operation is subject to the following two conditions: (1) this device may not cause harmful interference, and (2) this device must accept any interference received, including interference that may cause undesirable operation.

Class B Product

NOTE:

This equipment has been tested and found to comply with the limits for a Class B digital device, pursuant to Part 15 of the FCC Rules. These limits are designed to provide reasonable protection against harmful interference in a residential installation. This equipment generates, uses and can radiate radio frequency energy and, if not installed and

used in accordance with the instructions, may cause harmful interference to radio communications. However, there is no guarantee that interference will not occur in a particular installation. If this equipment does cause harmful interference to radio or television reception, which can be determined by turning the equipment off and on, the user is encouraged to try to correct the interference by one or more of the following measures:

- reorient or relocate the receiving antenna
- increase the separation between the equipment and receiver
- connect the equipment into an outlet on a circuit different from that to which the receiver is connected
- consult the dealer or an experienced radio/TV technician for help.

Warning: Any changes or modifications not expressly approved by Clipsal Integrated Systems could void the user's authority to operate this equipment.

Other International Directives and Standards

The 5500PS and E5500TPS products comply with the following:

Regulation	IEC Standard	Title
EMC	61000-4-2, 61000-4-3, 61000-4-4, 61000-4-5, 61000-4-6, 61000-4-11 61204-3	Immunity to ESD, Immunity to RFI, Immunity to EFT, Immunity to Surge Voltages, Immunity to Conducted RFI LV Power Supplies
Electrical Safety	61558-1, 61558-2-17	Safety of Power Supplies & Transformers

14.0 Warranty

The 5500PS Series C-Bus Power Supply carries a two year warranty against manufacturing defects (refer to the Warranty Statement).



Technical Support and Troubleshooting

For further assistance in using this product, consult your nearest Clipsal Integrated Systems Sales Representative or Technical Support Officer.

Technical Support Hotline: 1300 722 247 (Australia)
0800 888 219 (New Zealand)

Technical Support Email: techsupport.cis@clipsal.com.au

Sales Support Email: sales.cis@clipsal.com.au

A list of worldwide contacts, additional product information and technical resources is provided at <http://www.clipsal.com/cis/>

Product of Clipsal Integrated Systems Pty Ltd

ABN 15 089 444 931

Head Office

12 Park Terrace, Bowden, SA 5007, Australia

Telephone: (+61) 8 8440 0500

Facsimile: (+61) 8 8346 0845

Email: cis@clipsal.com.au

Web: <http://www.clipsal.com/cis/>

10358563