

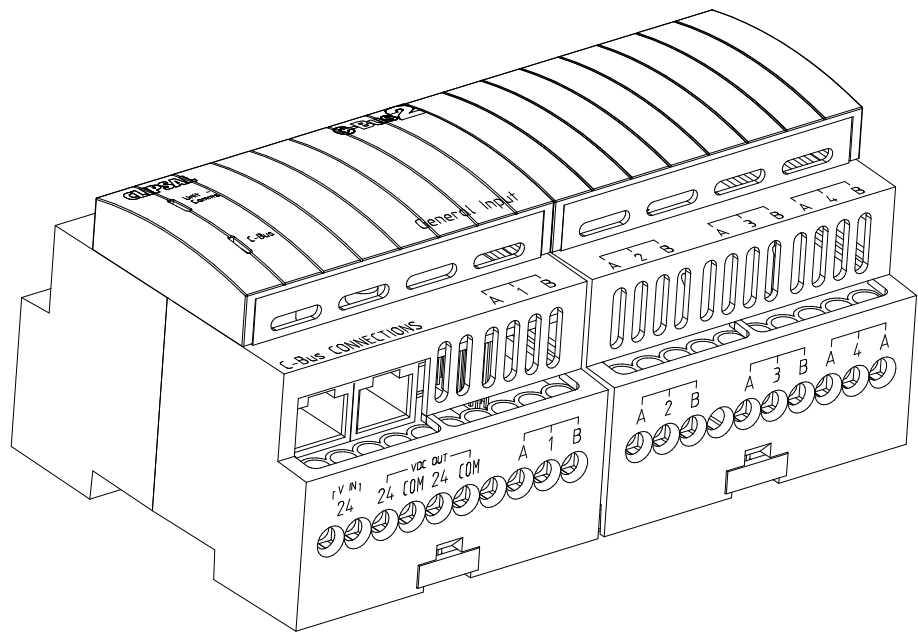

C-Bus Four Channel General Input Unit Installation Instructions

5504GI Series



REGISTERED DESIGN
REGISTERED PATENT



Table of Contents

Section.....	Page
1.0 Product Range	3
2.0 Description	3
3.0 Capabilities	3
4.0 Compatible Inputs	3
5.0 Wiring Instructions.....	4
6.0 Connection to the C-Bus Network	5
7.0 C-Bus Messaging	6
7.1 Programming Considerations:.....	6
8.0 Status Indicators	6
8.1 C-Bus Indicator	6
8.2 Unit Indicator	6
9.0 C-Bus System Clock	7
10.0 C-Bus Network Burden	7
11.0 Power-Up Status	7
12.0 Power Requirements.....	8
12.1 C-Bus	8
12.2 24Vac/dc Input	8
12.3 24Vdc Output	8
13.0 Power Surges and Short Circuit Conditions	8
14.0 Megger Testing	8
15.0 Standards Complied.....	8
16.0 Programming Requirements	8
17.0 Mechanical Specifications	9
18.0 Electrical Specifications	10

Copyright Notice

© Copyright 2003 Clipsal Integrated Systems Pty Ltd. All rights reserved.

Trademarks

- Clipsal is a registered trademark of Gerard Industries Pty Ltd.
 - C-Bus and C-Bus2 are registered trademarks of Clipsal Integrated Systems Pty Ltd.
 - Intelligent Building Series is a registered trademark of Clipsal Integrated Systems Pty Ltd.
- All other logos and trademarks are the property of their respective owners.

Disclaimer

Clipsal Integrated Systems reserves the right to change specifications or designs described in this manual without notice and without obligation.

1.0 Product Range

- 5504GI** C-Bus Four Channel General Input Module (with 24Vac @ 500mA AUS plug pack)
E5504GI C-Bus Four Channel General Input Module

2.0 Description

The 5504GI Series C-Bus Four Channel General Input (CBGIM) products are C-Bus input devices. This extra low voltage device should be mounted in accordance to local wiring rules (AS/NZS3000 or equivalent). For ease of installation they are DIN rail mounted, measuring 8M wide (1M = 17.5 +0.5/-0.0 mm) wide. C-Bus connection is conveniently achieved through the use of RJ45 connectors, allowing similar units to be quickly looped together. Four independent input channels capable of measuring voltage, current and resistance are provided to control other C-Bus devices.

3.0 Capabilities

The 5504GI Series C-Bus Four Channel General Input products are powered from the C-Bus and from an external 24Vac/dc supply.

These units can generate a C-Bus system clock signal and apply a network burden.

These units isolate the external power connections from the extra low voltage C-Bus Network.

4.0 Compatible Inputs

The 5504GI Series C-Bus Four Channel General Input products are suitable for use to measure voltage, current and resistance in the following ranges.

Input Specifications	Range
TTL Digital * (See Wiring Instruction 7)	0 to 5V dc
Voltage	0 to 1V dc
	0 to 5V dc
	0 to 10V dc
	0 to 20V dc
Current	0 to 20mA
	4 to 20mA
Resistance	0 to 500 Ohms
	0 to 1k Ohms
	0 to 3k Ohms
	0 to 10k Ohms

All input ranges feature user selectable filtering at mains frequency (or if using dc supply, at 50Hz).

Hysteresis, set during installation, is applicable to all inputs when determining if an action shall be performed.

Important Note:

The CBGIM is designed to monitor slow moving signals. All input signals are filtered using a median filter to reduce susceptibility to impulse noise. This means that signals faster than 10Hz cannot be followed. Maximum allowable input voltage for all ranges is +60/-20V. Voltages greater than this level may damage the CBGIM.

5.0 Wiring Instructions

1. All sensors wired to the device shall use their own cable. No commoning of connections is allowed.
2. All sensor cables shall run at least 500mm from any mains wiring.
3. Where possible the use of twisted pair shielded cable is preferred, with the shield being connected to the 24Vdc common terminal. Maximum cable lengths are dependant on notes 4, 5 and 6 below.
4. The current loop connections are distance limited by the cable resistance and the voltage required across the current loop transmitter. In calculating this distance, take into account that the current loop sensing resistor will drop 5V across it at the 20mA level. The current loop connection requires that the 24Vdc output be used to supply power to the sensor.
5. The resistance ranges operate by injecting current into the sensor. This current is 500uA. Sensor self-heating must be taken into account.
6. The resistance ranges use a 3 wire resistance measurement technique that takes cable resistance into account up to 2000 Ohms.
7. An externally powered logic gate or transistor output is required for a digital input.

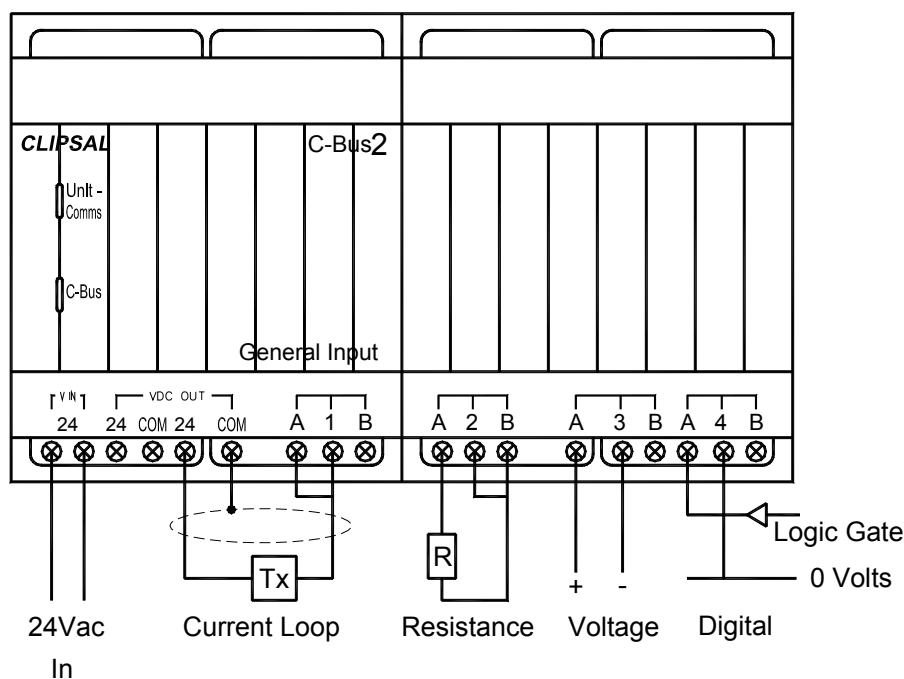

Figure 1. A typical wiring example

NOTE:

- Care must be taken not to allow copper strands to enter the DIN unit's apertures.
- Rubber bungs are supplied (3 off) for unused RJ45 connectors, to stop foreign bodies from entering the unit.
- A maximum torque of 1.4Nm should be applied to the mains rated screw terminals.
- It is recommended that the General Input unit be segregated from the mains terminals by use of a separate enclosure. Please refer to local wiring standards for isolation requirements between mains and extra low voltage wiring terminations.

6.0 Connection to the C-Bus Network

Installation requires connection to the unshielded twisted pair C-Bus Network Cable. The illustration following, shows the recommended technique for cable termination giving the best electrical performance. It is required that Category 5 data cable is used, Clipsal catalogue number 5005C305B.

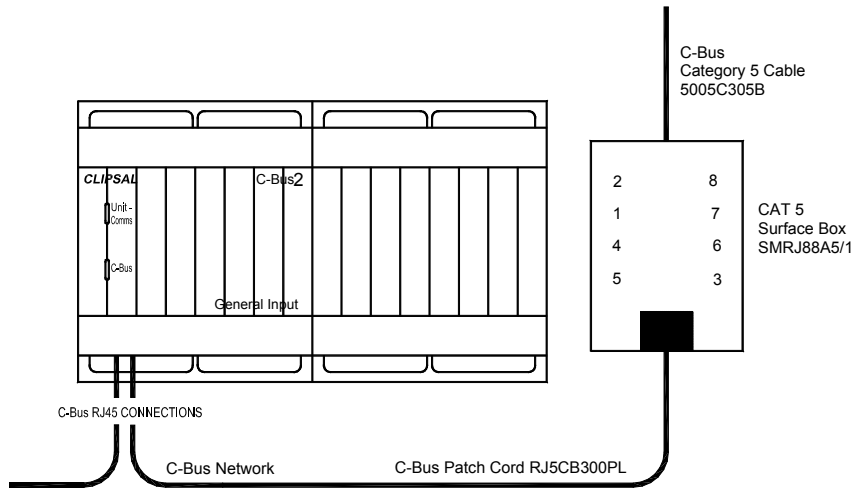
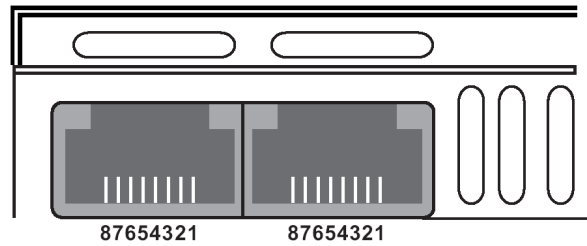

RJ Pin	C-Bus Connection	Colour
1	Remote ON	Green/White
2	Remote ON	Green
3	C-Bus Neg (-)	Orange/White
4	C-Bus Pos (+)	Blue
5	C-Bus Neg (-)	Blue/White
6	C-Bus Pos (+)	Orange
7	Remote OFF	Brown/White
8	Remote OFF	Brown

NOTE:

- The Remote Override (ON/OFF) functions are not available on this unit.
- It is recommended that the Remote Override (ON/OFF) connections be maintained for correct operation of these services across the C-Bus Network.

7.0 C-Bus Messaging

7.1 Programming Considerations:

The 5504GI Series C-Bus Four Channel General Input products can be programmed by connection to any operational C-Bus Network that is capable of supporting one or more extra C-Bus units (18mA current required) and a 24Vac/dc source. The unit can then be configured using the C-Bus Installation Software.

1. It is recommended that no more than 10 CBGIM units are on any one network.
2. Rapidly changing input levels will cause heavy C-Bus traffic and may lead to loss of other messages. Slowly moving input signals are preferred.
3. On noisy inputs, a higher level of hysteresis is recommended to reduce excessive messaging.
4. Too high a level of hysteresis could lead to total inoperability of the unit.
5. Select the longest time that results in acceptable performance for the Direct Level Sample Rate to reduce C-Bus traffic.
6. Global parameters must be set before channel parameters.
7. On heavy traffic systems, set the Broadcast timer to longer times to reduce traffic from the CBGIM.

For further information about the programming this and other C-Bus units, please refer to the C-Bus Technical Manual (5000S/2, 5000M/2).

8.0 Status Indicators

8.1 C-Bus Indicator

This indicator shows the status of the C-Bus Network at this unit. If sufficient network voltage and a valid C-Bus Clock signal are present then the 'OK' signal will be displayed (continuous green light). If a Network is connected which has more current load than the power supplies can support, then this indicator will flash to show a marginal Network voltage. If there is no C-Bus Clock present then this indicator will not light.

Indicator Status	Meaning
On	Power on and functional
Flashing	Insufficient power to support Network
Off	No C-Bus Clock signal present;

Further debugging of possible Network problems can be achieved with the Clipsal C-Bus Network Analyser tool (5100NA).

8.2 Unit Indicator

Indicator Status	Meaning
On	Normal operation
Off	No C-Bus connected

9.0 C-Bus System Clock

The 5504GI Series C-Bus Four Channel General Input product incorporates a software selectable C-Bus System Clock. The System Clock is used to synchronise data communications waveforms on a C-Bus Network. At least one active C-Bus System Clock is required on each C-Bus Network for successful communications. No more than three units on any C-Bus Network should have Clock circuitry enabled, so this option should normally be disabled using the C-Bus Installation Software.

If a System Clock is required, it can be enabled from the 'Global Tab' on the Graphical User Interface (GUI) for the unit.

10.0 C-Bus Network Burden

The 5504GI Series C-Bus Four Channel General Input product incorporates a software selectable Network Burden. The Network Burden can be enabled using the C-Bus Installation Software.

A Network Burden may or may not be required to ensure correct operation of the C-Bus Network. If in doubt, consult the C-Bus Calculator (Network Design Verification Software Utility) before proceeding with the hardware installation.

CAUTION:

The Graphical User Interface (GUI) software is designed to prevent the Burden from accidental selection. The following steps are required to correctly enable the Network Burden from the GUI:

1. Set the Unit Address to '001';
2. Turn to the 'Global Tab' of the GUI;
3. Select the Network Burden check box;
4. Click the OK button;
5. Select 'Save to Network' and/or 'Save to Database';
6. Click the OK button; then
7. Repeat steps 3 and 4 within 20 seconds, to save your selection.

To disable the Network Burden the same process applies except the Burden selection check box is cleared (remove cross).

Important Note:

Always disable all 5100 PC Interface Network Burdens before installing C-Bus DIN range products, which include a power supply (non "P" suffix versions). If a burden is required, use the built-in burden on the DIN Rail unit only.

11.0 Power-Up Status

All C-Bus units have onboard non-volatile memory, which is used to store the operating state of the unit in case of power loss. On restoration of power the DIN Rail General Input unit initiates a short power-up diagnostic routine, which lasts for approximately 5 seconds. For further information about the programming this and other C-Bus units, please refer to the C-Bus Technical Manual (5000S/2, 5000M/2).

12.0 Power Requirements

12.1 C-Bus

The 5504GI Series C-Bus Four Channel General Input product draws 18mA from the C-Bus Network.

Adequate C-Bus Power Supply Units must be installed to support the connected devices. If in doubt, consult the C-Bus Calculator (Network Design Verification Software Utility) before proceeding with the hardware installation.

12.2 24Vac/dc Input

The unit requires the connection of 16-27Vac to the V(in) terminals

12.3 24Vdc Output

The 24Vdc output is provided to supply power to external sensors and the current loop mode. This output is unregulated and is limited to 250mA.

13.0 Power Surges and Short Circuit Conditions

The external 24Vac/dc voltage must be limited to the range specified. Power surge protection devices should be used to enhance system immunity to power surges. It is strongly recommended that overvoltage equipment such as the Clipsal 970 be installed at the switchboard.

14.0 Megger Testing

Megger testing must never be performed on the C-Bus data cabling or terminals as it may degrade the performance of the Network.

Megger testing of mains wiring of an electrical installation that has C-Bus Units connected will not cause any damage to C-Bus Units. Since C-Bus Units contain electronic components, the installer should interpret megger readings with due regard to the nature of the circuit connection.

15.0 Standards Complied

Standard/Directive	Title
AS/NZS 1044:1995 IEC/CISPR14-1:1993 EN55014-1: 2000 CISPR14-1:2000	Limits and methods of measurement of radio disturbance characteristics of electrical motor-operated and thermal appliances for household and similar purposes, electric tools and similar electric apparatus
EN61000-3-2:2000; IEC61000-3-2:2000	Electromagnetic Compatibility (EMC) Part 3 Limits Section 2: Limits for Harmonic Current Emissions
EN60669-2-1:2000; IEC60669-2-1:1995	Switches for household and similar fixed electrical installations - Part 2: Particular requirements – Section 1: Electronic switches

16.0 Programming Requirements

The 5504GI Series C-Bus Four Channel General Input must be programmed to set a unique identification (Unit Address) and mode of operation on the C-Bus Network. C-Bus Installation Software can be used to configure the following:

- Project Name
- Part Name
- Unit Address
- Clock (Enable/Disable)
- Network Burden (Enable/Disable)
- Switching thresholds and hysteresis relationships

The C-Bus Installation Software can be downloaded from the Clipsal Integrated Systems Web Site (www.clipsal.com/cis).

For further information about programming this and other C-Bus units, please refer to the C-Bus Technical Manual (5000S/2, 5000M/2).

Important Warning

The use of any non-approved software in conjunction with the hardware installation without the written consent of Clipsal Integrated Systems may void any warranties applicable to the hardware.

17.0 Mechanical Specifications

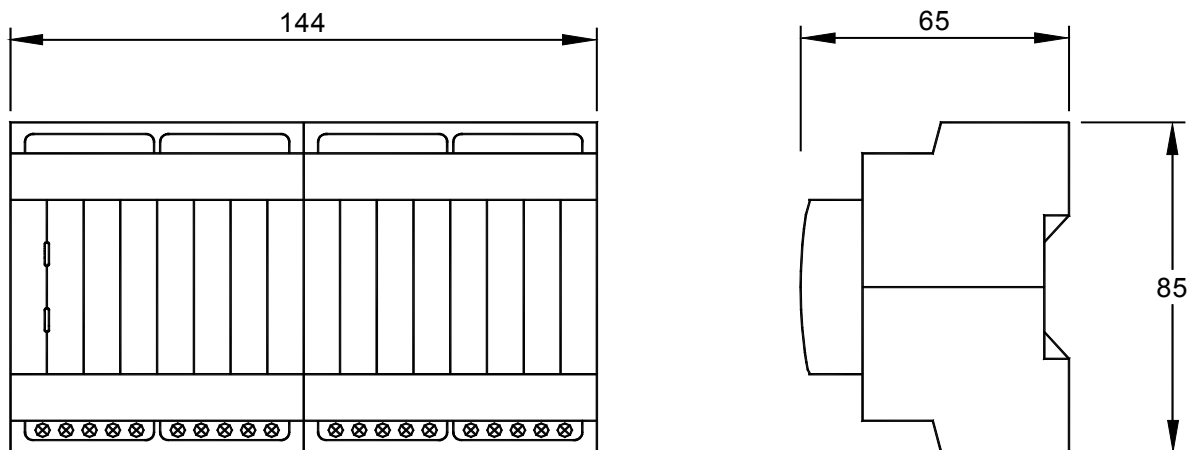

All dimensions are in millimeters.
No user serviceable parts inside.

18.0 Electrical Specifications

Catalogue No.	5504GI Series		
Nominal Supply Voltage	16-27Vac/dc		
Frequency Range(s)	50-60Hz		
C-Bus Supply Voltage	15-36Vdc		
C-Bus Current Drawn	18mA		
AC Input Impedance	100k Ω @1kHz A maximum of 10 units may be connected on a single C-Bus network		
Supply Current Drain With No External Loads	61mA		
24Vdc (nominal) Output Voltage	24Vdc \pm 10%		
24Vdc (Nominal) Current Source Capability	250mA Total		
Inputs			
Number of Input Channels	4		
Input Voltage Ranges	0 – 1Vdc, 0 – 5Vdc, 0 – 10Vdc, 0 – 20Vdc		
Maximum Input Voltages	-20 < V < +60 Vdc		
Input Voltage Range Impedance	\geq 100 k Ω		
Input Current Ranges	0 – 20mAdc, 4 – 20mAdc		
Current Sense Impedance	249 Ω		
Input Resistance Ranges	0 - 500 Ω , 0 - 1000 Ω , 0 - 3000 Ω , 0 - 10000 Ω		
Resistance Range Injection Current	500uA		
Basic Accuracy After Calibration	0.5% of Full-Scale		
Maximum Input Frequency	10Hz (see text 4.0)		
Control Functions	Load switching, Dimming, Trigger applications, Enable Control applications and Measurement applications		
Electrical Isolation	500V RMS / Input		
Status Indicators	C-Bus Indicator Voltage \geq 20V DC Voltage < 20V DC Voltage < 15V DC Unit Status Indicator On Off	Clock Present On Flashing Off C-Bus Present Present Fail	No Clock Present Off Off Off Conditions Normal Operations
Maximum Number of Units on a Single C-Bus Network	10		
Start Up Time	5 seconds from application of DC supply		
Network Clock	Software selectable (Factory default is disabled)		
Network Burden	Software selectable		
Dimensions	144 x 85 x 65 mm		
Weight	190g		
C-Bus Connections	2 x RJ45 sockets		
Operating Temperature Range	0-45 $^{\circ}$ C		
Operating Humidity Range	10 – 95% RH		

Further Information

For further information about configuring this product and other C-Bus devices, please consult the documentation supplied. Further assistance can be obtained as follows:

- **C-Bus Manuals**

The 5000M/2 C-Bus Technical Manual provides a comprehensive and definitive guide to Clipsal C-Bus. Includes hardware and software specifications, product datasheets, system design and installation guides, and software overview with fully worked programming examples.

- **C-Bus Installation Software**

The 5000S/2 C-Bus Installation Software (includes 5000M/2 C-Bus Technical Manual) may be used to unlock the power and flexibility of Clipsal C-Bus. Unit operation may be completely customised to suit user requirements. Advanced control functions may be programmed.

- **C-Bus Installer Training Courses**

Contact your nearest Clipsal Integrated Systems Sales or Technical Support Officer and enquire about Clipsal C-Bus Installer Training and Certification Programs today !!

- **Technical Support and Troubleshooting**

For further assistance, please consult your nearest Clipsal Integrated Systems Sales Representative or Technical Support Officer.

Technical Support Hotline

1 300 722 247

(Cost 25¢ per call, Australia Only)

Technical Support Email

techsupport.cis@clipsal.com.au

Sales Support Email

sales.cis@clipsal.com.au

Clipsal Integrated Systems Website

clipsal.com/cis

Products of Clipsal Integrated Systems Pty Ltd

ABN 15 089 444 931

Head Office

12 Park Terrace, Bowden

South Australia 5007

International Phone +61 8 8269 0560

International Fax +61 8 8346 0845

Internet clipsal.com/cis

E-Mail cis@clipsal.com.au

1036429