



C-Bus Four Channel Voltage Free Relay, 20A

Installation Instructions

5504RDP Series

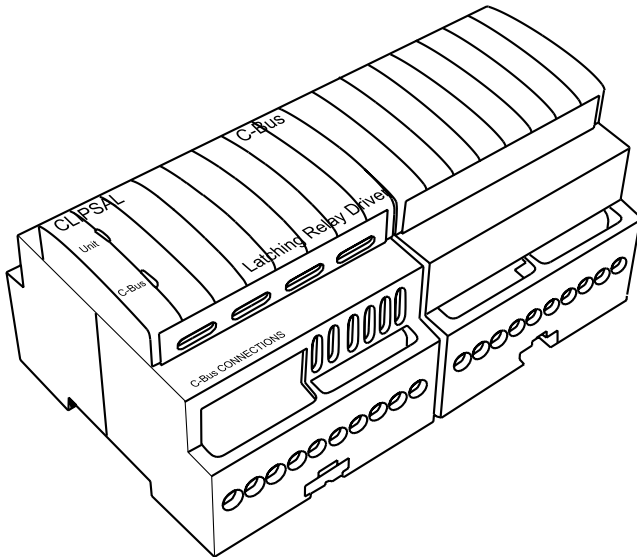

Table of Contents

1.0	Product Range	4
2.0	Description	4
3.0	Capabilities	4
4.0	Compatible Loads	4
5.0	Wiring Instructions	4
6.0	Remote Override Facility	5
7.0	Priority of Operating Modes	6
8.0	Indicators	6
8.1	C-Bus Indicator	6
8.2	Unit indicator	6
9.0	Power-Up Load Status	7
10.0	C-Bus Power Requirements	7
11.0	Stand-Alone Programming	7
12.0	Connection to the C-Bus Network	7
13.0	Programming Requirements	8
14.0	Power Surges and Short Circuit Conditions	8
15.0	Megger Testing	8
16.0	Important Warning	8
17.0	Standards Complied	8
18.0	Product Specifications	9
19.0	Mechanical Specifications	10

© 2001 Copyright Clipsal Integrated Systems Pty Ltd. All rights reserved.

Clipsal is a registered trademark of Gerard Industries Pty Ltd.

C-Bus is a registered trademark of Clipsal Integrated Systems Pty Ltd

Intelligent Building Series is a registered trademark of Clipsal Integrated Systems Pty Ltd

All other logos and trademarks are the property of their respective owners.

Disclaimer: Clipsal Integrated Systems reserves the right to change specifications or designs described in this manual without notice and without obligation.

1.0 Product Range

- 5504RDP** Four Channel Latching Relay Driver, (220-240Vac, 50-60Hz)
- E5504TRDP** Four Channel Latching Relay Driver, (110-120Vac, 50-60Hz)

2.0 Description

The 5504RDP products are C-Bus output devices designed to be used in a switchboard application. For ease of installation they are DIN rail mounted, measuring 8M wide. Four independent relay driver outputs are provided for driving specified latching relay coils.

3.0 Capabilities

C-Bus connection is conveniently achieved through the use of RJ45 connectors, allowing similar units to be quickly looped together. All units have no C-Bus power supply, and consume no current from the C-Bus network during normal operation. Remote ON and OFF facilities are available, permitting all channels to be turned ON or OFF without C-Bus network communication. These units isolate the mains power from the safe extra low voltage C-Bus network.

4.0 Compatible Loads

The C-Bus Four Channel DIN Rail Latching Relay Driver unit is suitable for use with either 5000RL20 or 50002RL20 Latching Relay modules.

5.0 Wiring Instructions

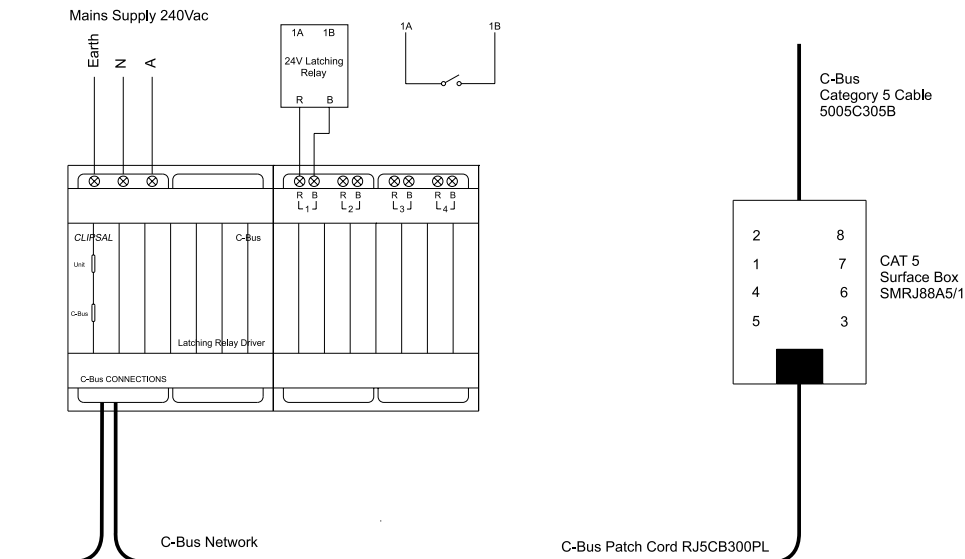

The DIN Rail Relay Driver is capable of handling up to four channels of external latching relay loads (described above). The installer should make adequate consideration for the total current consumption when selecting power feed cables. It is recommended that multiple feed cables be allowed for.

Notes:

1. A maximum of 100 units may be interconnected.
2. The installer must fix mains cabling in the distribution board using cable ties or trunking as required by local wiring rules. Care must be taken not to allow copper strands to enter DIN unit apertures.
3. The wires between the driver and relay coil are at C-Bus potential and hence require correct isolation from mains.

6.0 Remote Override Facility

Remote control of all channels on a unit can be achieved via the extra pairs of conductors on the C-Bus connector. C-Bus is a balanced network and thus any point where C-Bus negative (-) is taken, C-Bus positive (+) must also be present. Hence both network conductors must be looped through all remote input switches on the network. The diagram shows that switches may be connected in parallel on any one network, using the green and green/white conductors for a remote ON function. Brown and brown/white may be wired in the same fashion for remote OFF, with these conductors being connected to C-Bus negative (-) via the switch to action this state. A Clipsal 30/1/2LM mechanism makes an ideal remote input switch.

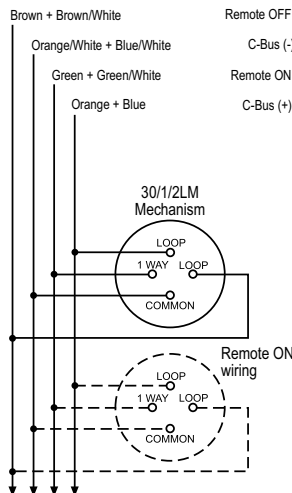

7.0 Priority of Operating Modes

The output status of a DIN Rail Series relay unit can be changed by pressing a C-Bus Key, or by using the Remote Override facilities.

The table below shows the priority ranking of these control inputs.

Mode	Priority	Function
Remote OFF	1 (Highest)	Turns all channels OFF
Remote ON	2	Turns all channels ON
C-Bus Input Unit (Key, PIR etc)	3 (Lowest)	Control the channel

8.0 Indicators

8.1 C-Bus Indicator

This indicator shows the status of the C-Bus Network at this unit. If sufficient network voltage and a valid C-Bus clock signal are present then the 'OK' signal will be displayed (continuous green light). If a network is connected which has more current load than the power supplies can support, then this indicator will flash to show a marginal network voltage. If there is no C-Bus clock present then this indicator will not light.

Indicator	Meaning
On	C-Bus network operational
Flashing	Insufficient power to support network
Off	No C-Bus clock signal present

Further debugging of possible network problems can be achieved with the Clipsal C-Bus Network Analyser tool (5100NA).

8.2 Unit Indicator

This indicator shows the status of the individual unit. When mains is supplied to the unit 'OK' will be displayed (continuous green light). If any of the four channels have been toggled (using Remote Override facilities) into a state other than is present on the C-Bus network, this indicator will flash with a 80% ON duty cycle. When the unit is powered from C-Bus only for stand-alone programming, this indicator will not function.

Indicator	Status Meaning
On	Normal operation
Flashing	Unit in override mode
Off	No mains connection

9.0 Power-Up Load Status

All C-Bus units have onboard non-volatile memory which is used to store the operating state of the unit in case of a power loss. The 5504RDP products drive latching relays, and will therefore retain the current output status if C-Bus power is lost. On restoration of power, the DIN Rail Latching Relay Driver unit initiates a short power-up diagnostic (approximately 5 seconds). User programmable options then allow the relay status to be set as desired.

10.0 C-Bus Power Requirements

The C-Bus DIN Rail Relay Unit draws 18mA from the C-Bus network when it is not connected to mains supply. With mains voltage connected no current is drawn by the unit.

11.0 Stand-Alone Programming

The 5504RDP products can be programmed without a mains connection. The unit can be connected to any operational C-Bus network that is capable of supporting one or more extra C-Bus units (18mA current required). The unit can then be configured using C-Bus Installation Software.

12.0 Connection to the C-Bus Network

It is recommended that Category 5 data cable be used, Clipsal catalogue number 5005C305B. Installation of the 5504RDP products requires connection to the unshielded twisted pair C-Bus Network Cable. This connection is polarity sensitive, and is clearly shown in the diagram below.

A Clipsal RJ5CB300PL Cat 5 UTP patch cord is included with the unit for easy inter-connection. No more than 100 x 5504RDP Series products should be connected to one physical C-Bus network.

Pin	Connection	Colour
1	Remote ON	Green/White
2	Remote ON	Green
3	C-Bus Neg (-)	Orange/White
4	C-Bus Pos (+)	Blue
5	C-Bus Neg (-)	Blue/White
6	C-Bus Pos (+)	Orange
7	Remote OFF	Brown/White
8	Remote OFF	Brown

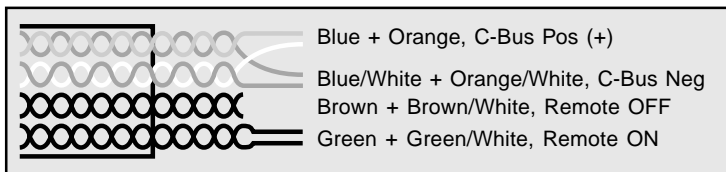
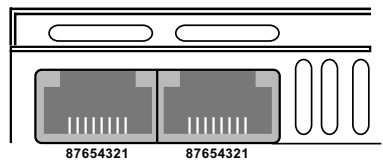

13.0 Programming Requirements

As with other C-Bus units, the Latching Relay Driver Units must be programmed to set their unique identification and the mode of operation on the C-Bus Network. The C-Bus Installation Software can be used to configure all operational parameters including the specification of control sources, and power up options.

14.0 Power Surges and Short Circuit Conditions

The mains voltage must be limited to the range specified for any unit which is mains powered. Each unit incorporates transient protection circuitry and additional external power surge protection devices should be used to enhance system immunity to power surges. It is strongly recommended that over-voltage equipment such as the Clipsal 970 Series is installed at the switchboard.

15.0 Megger Testing

Megger testing of an electrical installation that has C-Bus units connected will not cause any damage to C-Bus units. Since C-Bus units contain electronic components, the installer should interpret megger readings with due regard to the nature of the circuit connection.

16.0 Important Warning

The use of any non C-Bus Software in conjunction with the hardware installation without the written consent of Clipsal Integrated Systems may void any warranties applicable to the hardware.

17.0 Standards Complied

The units have been designed to meet Australian and European standards for EMC Compliance and Safety.

AS/NZS 3100:1997 General Requirements for Electrical Equipment
AS/NZS 3108:1994, IEC 742: 1983 Requirements for Safety Extra Low Voltage
97/32C/EEC Low Voltage Directives
AS/NZS 1044:1995, IEC/CISPIR 14:1993, BS/EN 55014: 1994 RFI Emissions Standard
AS/NZS 4051:1998, IEC/CISPR 15: 1996, BS:EN 55015: 1994 RFI Emissions Standard
IEC 669-2-2, BS/EN 60669-2-2 Particular Requirements for Remote Control
Switching Devices
BS/EN 61000-4-2 Immunity to Electrostatic Discharge
BS/EN 61000-4-3 Immunity to Radio Frequency Interference
BS/EN 61000-4-4 Immunity to Electrical Fast Transients
BS/EN 61000-4-5 Immunity to Surge Voltages
BS/EN 61000-4-11 Immunity to Voltage Dips and Interruptions
89/336/EEC Electromagnetic Compatibility Directive

18.0 Product Specifications

Cat. No.	5504RDP	E5504TRDP	
Nominal Supply Voltage	220-240V~	110-120V~	
Frequency Range(s)	47-53Hz and 57-63Hz		
C-Bus Supply Voltage	15-36V DC @ 18mA required for programming when mains power is not connected. 15-36V DC @ 0mA when mains power is connected. Does not source current to the C-Bus network.	15-36V DC @ 18mA required for programming when mains power is not connected. 15-36V DC @ 0mA when mains power is connected. Does not source current to the C-Bus network.	
AC Input Impedance	100k Ω @ 1kHz A maximum of 100 units may be connected on a single C-Bus network	100k Ω @ 1kHz A maximum of 100 units may be connected on a single C-Bus network	
Electrical Isolation	3.75kV RMS from C-Bus to mains		
Status Indicators	C-Bus Voltage \geq 20V DC On Voltage < 20V DC Flashing Voltage < 15V DC Off Unit Status On Flashing Off	Clock Present On Flashing Off Mains Power Present Present Fail	No Clock Present Off Off Off Conditions Normal Operation Remote Override Mode Mains power not available
Maximum Number of Units on a single C-Bus Network	100	100	
Relay Load Rating	Latching Relay Coil voltage 24V (5000RL20 or 5002RL20)	Latching Relay Coil voltage 24V (5000RL20 or 5002RL20)	
Contact Type	Voltage Free, Normally Open, Magnetically Latched		
Relay Drive Pulse Time	20mS	20mS	
Quiescent Power	4 Watts		
Warm Up Time	5 seconds		
Network Clock	Not available		
Network Burden	Not available		
Dimensions	144 x 85 x 65mm		
Remote Override Input	Remote switch input can be daisy chained to a maximum of 100 units and a maximum of 1000m of cable	Remote switch input can be daisy chained to a maximum of 100 units and a maximum of 1000m of cable	
Mains Terminal	Accommodates 2 x 1.5mm ² or 1 x 2.5mm ²		
Weight	348g		
C-bus Connection	RJ45 socket		
Remote Override Connection	RJ45 socket		
Operating Temperature Range	0 - 45°C		
Operating Humidity Range	10 - 95% RH		

19.0 Mechanical Specifications

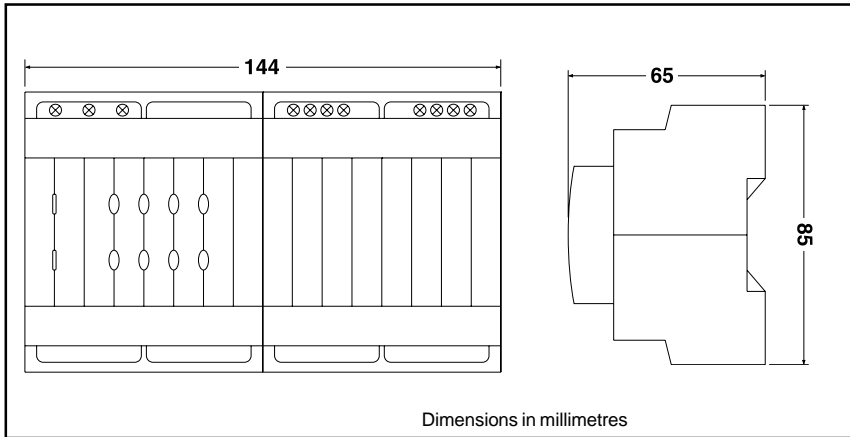

No user serviceable parts inside

Technical Support and Troubleshooting

For technical support on this product please call the Clipsal Integrated System's call centre on

1300 722 247

(In Australia only)

For further assistance in using C-Bus, please consult your nearest Clipsal Integrated Systems Sales Representative or Technical Support Officer.

Technical Support Email techsupport.cis@clipsal.com.au

Sales Support Email sales.cis@clipsal.com.au

Clipsal Integrated Systems Website

clipsal.com/cis

Please visit the Clipsal Integrated Systems' Website for information on new product developments, online software registration, software upgrades, plus much more.

Products of Clipsal Integrated Systems Pty Ltd

ACN 089 444 931 ABN 15 089 444 931

Head Office

12 Park Terrace, Bowden
South Australia 5007
PO Box 103, Hindmarsh
South Australia 5007

Telephone (08) 8269 0560
International +61 8 8269 0560
Facsimile (08) 8346 0845
International +61 8 8346 0845
Internet clipsal.com/cis
E-Mail cis@clipsal.com.au

Offices in all States

NSW	Sydney	(02) 9794 9200
	Albury	(02) 6041 2377
VIC	Melbourne	(03) 9207 3200
	Country Areas	1800 653 893
QLD	Brisbane	(07) 3244 7444
	Townsville	(07) 4729 3333
SA	Adelaide	(08) 8269 0555
WA	Perth	(08) 9442 4444
TAS	Hobart	(03) 6272 3177
	Launceston	(03) 6343 5900
NT	Darwin	(08) 8947 0278

International Enquiries

Head Office Export Department

Telephone +61 8 8269 0587
Facsimile +61 8 8340 7350
E-Mail export@clipsal.com.au

New Zealand

Clipsal Industries (NZ) Ltd (Auckland)

Telephone (09) 576 3403
Facsimile (09) 576 1015
E-Mail headoffice@clipsal.co.nz

Customer Service

Free Fax (0508) 250 305
Auckland/Mobile Phone (09) 572 0014
Free Phone (0508) CLIPSAL
2547725

Malaysia

Clipsal Integrated Systems (M) Sdn Bhd
Level 3, Unit 3-2, CP Tower
Jalan Damansara
46350 Petaling Jaya
Malaysia
Telephone +61 +603 7665 3555
Facsimile +61 +603 7665 3155
E-mail clipsal@clipsaltech.com.my

Singapore

CIS Pte Ltd (Singapore)
No. 8, Jurong Town Hall Road
#24-05-06 The JTC Summit
Singapore 609434
Telephone +65 (266) 1998
Facsimile +65 (266) 3922
E-mail clipsal@clipsaltech.com.sg

International Representatives

Argentina

Controles Tecnova S.A. (114) 207 9534

China

Clipsal (China) Ltd (755) 246 1122

Greece

Clipsal Hellas S.A. (1) 600 3718

Middle East

Clipsal Middle East (6) 557 0777

South Africa

Clipsal South Africa (Pty) Ltd (11) 314 5200

Taiwan

Clipsal (Taiwan) Co Ltd (2) 2558 3456

Thailand

Clipsal Thailand Ltd (2) 952 5338

United Kingdom

Clipsal Ltd (UK) (44) 1494 521111

Vietnam

Clipsal – VTEC (8) 856 3002