

# INSTALLATION GUIDE



Home  
Networking  
Solutions



# CLIPSAL STARSERVE® INSTALLATION GUIDE - CONTENTS

## Section 1 - What is Clipsal StarServe®?

What is Clipsal StarServe®? .....	4
Video distribution.....	4
Telephone and Data Distribution.....	5

## Section 2 - Introduction to MATV Basics

MATV Introduction .....	6
Signal Strength.....	7
Signal Quality.....	8
Signal Losses - Cable.....	9
Signal Losses - Splitters.....	10
Choosing the Right Antenna .....	11

## Section 3 - Clipsal StarServe® Product Introduction

3105ABEN Slimline Enclosure .....	12
8000LEN Lite Sized Enclosure.....	13
8000MEN Mid Sized Enclosure.....	14
3105PENF / 3105PENS Professional Enclosures .....	15
Video Distribution Units.....	16-17
3105VDU38IRT Distribution Unit .....	18
3105VDU24T Distribution Unit .....	19
8073/8VHPIR Video Hub.....	20
8072/6VHP Video Hub.....	21
Clipsal StarServe® VDU Power Options .....	22
Power Injector .....	23
Local Powering of the VDU - Plug Pack.....	24
Clipsal Digital Ready Antennas .....	25
Modulators.....	26
Emitter Leads & Infrared Targets .....	27
Patch Panels - Data and Telephone.....	28
Switches - Data Patch Panels .....	29
8001/4EX Output Expander .....	30
8000INJ IR Injector .....	30
8000DCB Coaxial DC Block.....	31
8000SS Surge Suppressor .....	31
8000AVB RCA to Cat-5 Cable Adaptor.....	31

## Section 4 - Minimum TV Cabling Requirements

TV Cabling Requirements .....	32
F-Type Connectors.....	32
MATV Tools Required.....	32
TV Mechs.....	33
TV Fly Leads .....	33
Digital Terrestrial Meter .....	33
Conventional TV Cabling.....	34
Clipsal StarServe® TV Cabling .....	35
3105VDU38IRT TV Wiring Diagram .....	36
3105VDU24T TV Wiring Diagram .....	37
8073/8VHPIR TV Wiring Diagram .....	38
8072/6VHP TV Wiring Diagram.....	39

## Section 5 - Video Distribution - How To Connect

Antenna Input .....	40
Antenna Input - Using an Amplifier with the VDU .....	41
Antenna Outputs.....	42
Modulator Input B - Distribution of Devices.....	43
Setup of the Modulator.....	44
Modulator AV Connections .....	45
Modulator AV Connections - Y-Lead Connections.....	46
IR Emitter Leads .....	47
IR Target.....	48
IR Control of Devices.....	49

Modulator Input A - Single Surveillance Camera .....	50
Modulator Input A - Multiple Surveillance Cameras .....	51
Surveillance Camera Connection Using an AV Balun.....	52
Connecting More Than Eight Outputs .....	53

## Section 6 - Phone/Data Minimum Cabling Requirements

Telephone/Data Cabling .....	54
Telephone/Data Outlets and Patch Panels .....	54
Patch Leads .....	54
Required Data Tools .....	54
Recommended Cabling for Telephone and Data Requirements .....	55

## Section 7 - Telephone/Internet - How To Connect

Telephone Connection .....	56
Jumpering Telephone Outlets .....	57
Mode 3 Connection.....	58
ADSL Connection .....	59
ADSL Connection with Jumpering Leads .....	60
ADSL Switch Modem Router Connection.....	61

## Section 8 - Data Cabling - How To Connect

Patch Panel Setup - Data Cabling .....	62
Patch Panel Connection for Structured Cabling System.....	63
Telephone Distribution Using a Telephone Patch Panel.....	64

## Section 9 - Subscription TV Cabling Requirements/Overview

Foxtel IQ Cabling Requirements - Domestic .....	65
Austar Cabling Requirements - Domestic .....	66
Multiple Subscription TV Decoder Cabling Requirements - Domestic .....	67
Apartment Cabling Requirements - Commercial Installations.....	68

## Section 10 - Cabling Considerations

Key Area 1 - The Lounge Room.....	69
Typical Locations.....	69
Future Distribution of Services.....	69
Foxtel/Austar .....	69
Key Area 2 - The Master Bedroom .....	70
Key Area 3 - Other Bedrooms.....	70
Key Area 4 - Study/Other Bedrooms .....	70
Key Area 5 - The Kitchen .....	71
Smart Wired Wall Plate .....	71
Other Areas .....	71

## Section 11 - Clipsal Audio Solutions

Clipsal Audio Solutions Product Introduction.....	72
Speaker Options, Tools and Cabling .....	72
Infrared Control of the Source .....	73
Clipsal Audio Solutions Wiring .....	73
Clipsal Audio Solutions Loop Wiring.....	74
Clipsal Audio Solutions Star Wiring .....	74
Clipsal Audio Solutions and Clipsal StarServe®.....	75

## Section 12 - Troubleshooting Guides

Infrared Troubleshooting Guide.....	76-77
TV Reception Troubleshooting Guide - Free to Air Picture.....	78-79
TV Reception Troubleshooting Guide - Modulated Channels.....	79

## Section 13 - Clipsal StarServe® FAQs

Preface .....	80
FAQs .....	80-81

## Back Page - Clipsal StarServe® Service Agent

## What is Clipsal StarServe®?

Clipsal StarServe® is three distribution systems in one for the home:



Digital and analogue  
video distribution

AND/OR



Telephone/internet  
distribution

AND/OR



Data networking

You can take advantage of just one or utilise all three areas - the choice is yours.

## Video Distribution

Apart from distributing analogue or digital free and air TV, Clipsal StarServe® also enables the user to distribute other devices such as DVD players, video recorders, subscription TV decoders and surveillance cameras to be viewed on any TV connected to the Clipsal StarServe®.

Now every TV in your home can access free to air channels, subscription TV decoders, DVD players, video recorders and surveillance cameras etc.

Clipsal StarServe® unlocks your home entertainment centre. Now everyone can watch what they want when they want to watch it.

Some models will allow the IR control of these other devices from rooms other than the main entertainment area.

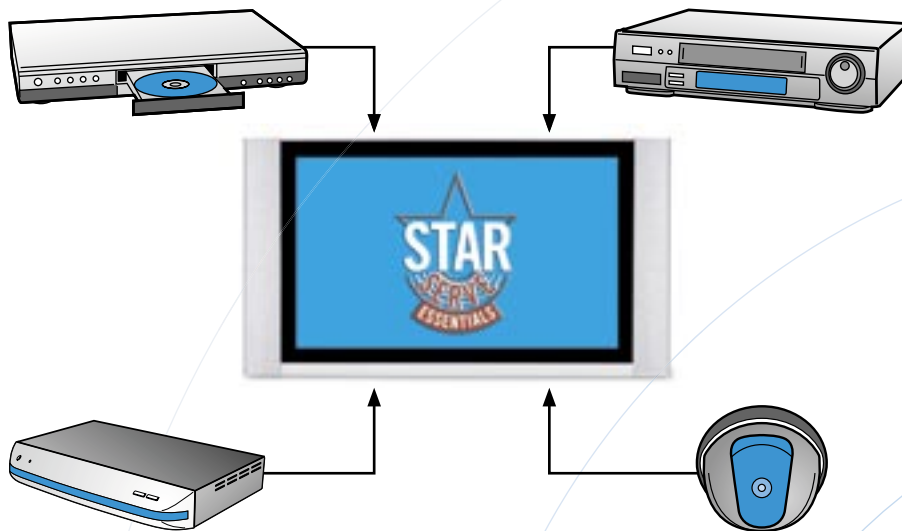

Only TWO extra coax cables are required in addition to the standard TV cabling.



## Telephone and Data Distribution

In today's homes the need to have telephone access and internet access is essential.

Clipsal StarServe® facilitates the distribution of telephone and Internet cabling in a simple and easy to understand manner. Clipsal StarServe® can also facilitate a high-speed data network so that you can network computers, printers and AV equipment together.

Hard wired cabling is the best possible solution for any installation but failure to prepare for cabling may be very costly in the future. The cost of trying to install cabling after a new home has been built is approximately three to four times the initial cost. If you have a two storey home then it may be impossible to get cables down walls unless you make holes and damage walls or ceilings.

Even if you are going to have a wireless network within you home, Clipsal StarServe® can accommodate this requirement and connect your wireless network to the Internet.

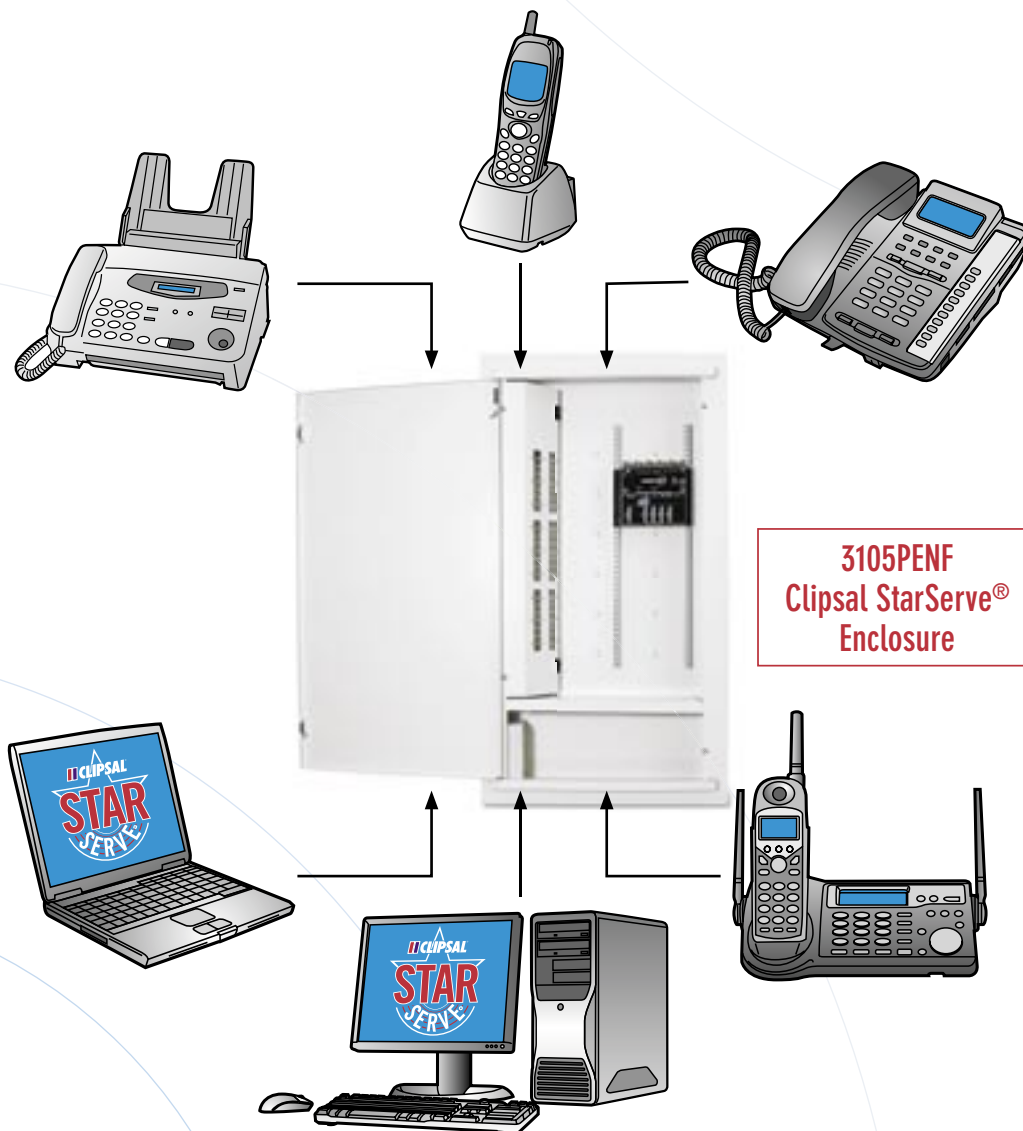

## MATV Introduction

### What does MATV stand for?

Master Antenna TeleVision:

The master antenna is used for supplying one TV outlet, or multiple TV outlets with TV signals. The most basic MATV system is an antenna connected to a TV outlet, along with a fly lead to connect the system to the TV.

The antenna is designed to receive TV signals. The cable is designed to carry the TV signals to the outlet. The outlet is the interface for a fly lead to connect to the TV. The fly lead connects the wall plate to the TV.

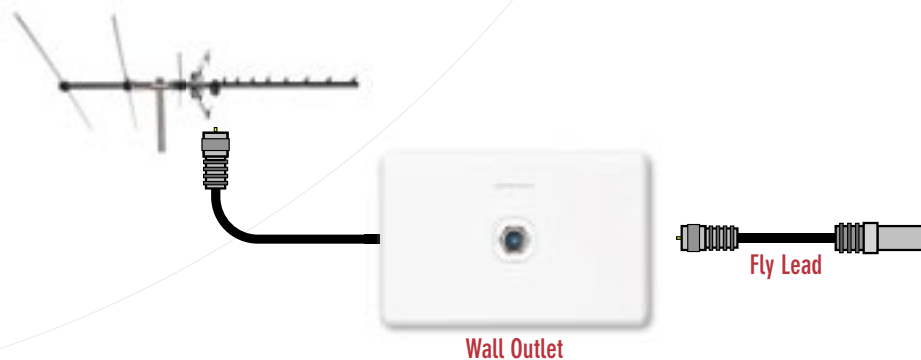

Where multiple outlets are required a splitter or series of splitters are used to distribute the signal to as many outlets as required.

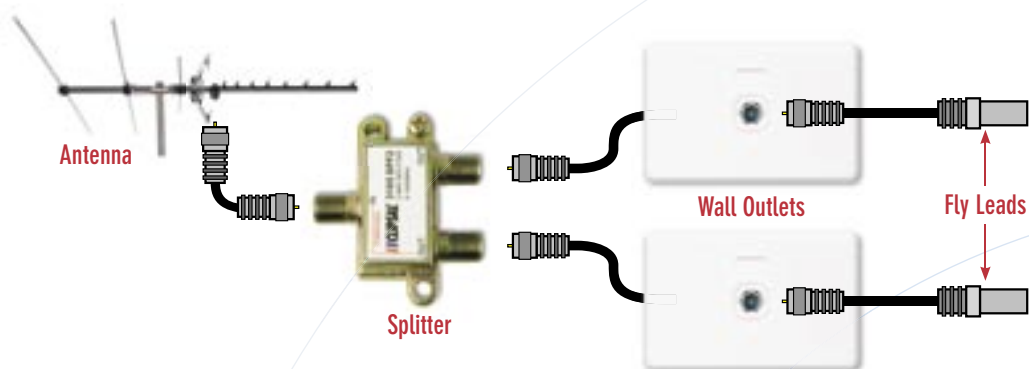

The antenna is designed to receive the TV signal.  
The cabling system is designed to carry the TV signal to the TV without any interference.

**IMPORTANT NOTE:**  
All Clipsal MATV products including Clipsal StarServe® are capable of distributing DIGITAL AND ANALOGUE free to air TV signals.

## Signal Strength

The principals of signal strength for MATV systems are not unlike that of the electrical principals for voltage at power points.

The units of measurement are as follows:

- **electrical unit of measurement is the Volt (V)**
- **MATV unit of measurement is the decibel Micro Volt (dBuV), commonly referred to as “dB”.**

The ideal voltage for a power outlet is 240 Volts, with a tolerance of 5%. This means that you can have as low as 228 Volts or as high as 252 Volts to comply with the Australian Standards.

The voltage is measured using a multimeter. You set the multimeter to the voltage setting and test for voltage. The ideal Signal level for a combined analogue / digital MATV system is similar.

The ideal MATV signal strength at the outlet is 69dBuV with a tolerance of 5%. For excellent quality pictures, you require signal strength between 65-72dBuV. The MATV signal strength is measured using a field strength meter. You set the field strength meter to the channel you wish to test and it will show you a reading of the signal at the outlet.

### Ideal Signal Levels

MATV Outlet - 69dBuV



Standard Outlet - 240V

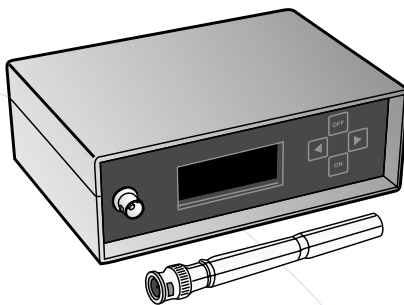

Test with field strength meter

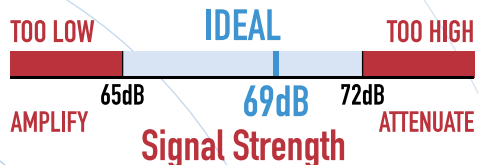

Test with multi meter

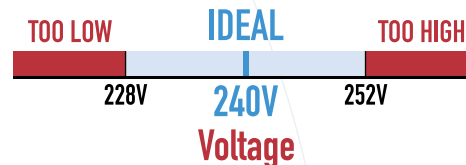

**A field strength meter is ESSENTIAL.**

Signal Quality

There are two parts to a perfect TV picture, signal strength and signal quality. You can have excellent signal strength but if your signal quality is poor then this will result in poor quality pictures.

Many of the problems faced with signal quality have been overcome with the introduction of digital TV. For example with digital TV you will not get ghosting. Clear line of sight is obviously the best possible scenario for high quality TV reception but often cannot be achieved.

We need to avoid the following when installing antennas:

- **DO NOT** install antennas in the ceiling space
- **DO NOT** install antennas with trees in the way of line of sight
- **DO NOT** install antennae within one metre of the roof.

Before you install an antenna:

- **DO** a site survey; this is a walk on the roof with an antenna and digital field strength metre. This will give you an indication of the best possible location to install the antenna on the roof.
- **DO** check each TV station on the site survey. This confirms that it is the best possible location for all TV stations reception.



Bit error rate

**BER** – Bit error rate measures the number of errors on the incoming signal. Too many errors will result in pixilation, boxing or freezing of the picture. There is a four star rating associated with digital signal reception:



No picture



Pixelated picture

★ FAIL	★★ FAIL	★★★ PASS	★★★★ PASS
VERY POOR QUALITY	POOR QUALITY	GOOD QUALITY	EXCELLENT QUALITY



It is the installer's responsibility to follow the appropriate Occupational Health and Safety (OH&S) work practices.



## Signal Losses - Cable

Losses are a part of any MATV system. You may start out with an acceptable signal level at the antenna but due to losses in the cable or splitter, the signal may not be acceptable when at the outlet.

Losses are calculated separately for VHF and UHF frequencies. The golden rule is the higher the frequency the higher the loss.

<b>VHF = Very High Frequency</b>	45 - 470 MHz	Channels 0 - 12
<b>UHF = Ultra High Frequency</b>	471 - 860 MHz	Channels 21 - 69

We need to calculate losses for both VHF and UHF in every TV design to ensure that we have a balanced system. Clipsal RG6 cable losses are linear. This means that you can multiply the losses for one metre by the length of the cable run to get the losses over that distance.

2B6QXX Cable Losses	Frequency	1.0m	5.0m	10.0m	20.0m	30.0m
	VHF (0-12)	0.053dB	0.265dB	0.53dB	1.06dB	1.59dB
	UHF (21-69)	0.21dB	1.05dB	2.1dB	4.2dB	6.3dB

A balanced system is a MATV system that has an acceptable signal level (65-72dBuV) at every outlet within the system, regardless of the length of cable to the outlet.

In domestic settings this is not usually an issue if the distribution of the signal is from a central location. This is more of an issue when distributing TV signals to multi storey apartments and hotels with long cable runs.

In a domestic situation the shortest cable run can be one metre and the longest cable run can be 35 metres without having to use some form of equalisation to balance the system.

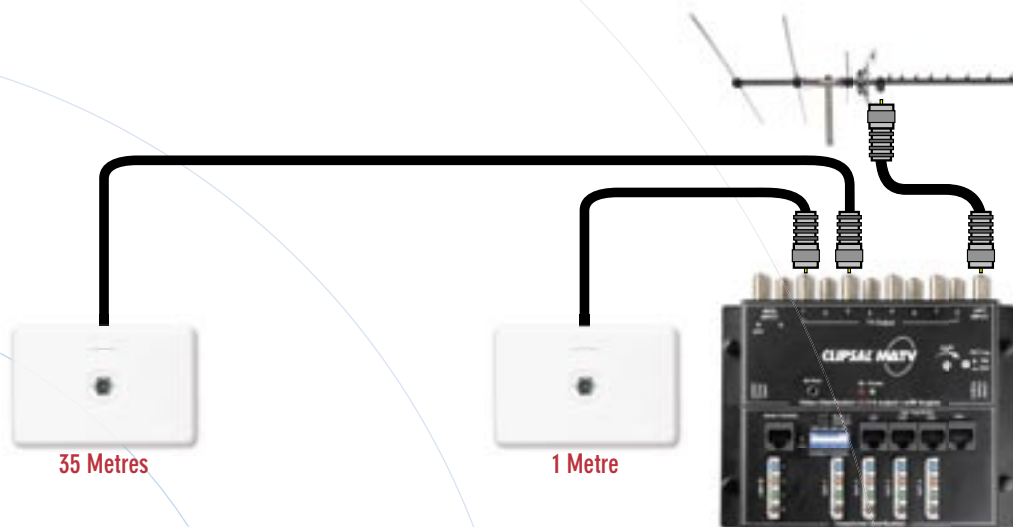

Signal Losses - Splitters

Losses over splitters are just as important to calculate as the losses over cable. The value of the loss will be different for VHF and UHF (the golden rule is the higher the number of splits, the higher the losses).

The Clipsal StarServe® VDU is a **NO-LOSS SPLITTER**.

The losses over each output port of the splitter are the same.

If you changed a two way splitter for a four way splitter you may have poor picture quality due to the fact that you have added losses into the system and reduced the signal strength to each outlet by 4dB on VHF and 3.4dB on UHF. An eight way splitter would also require an amplifier.

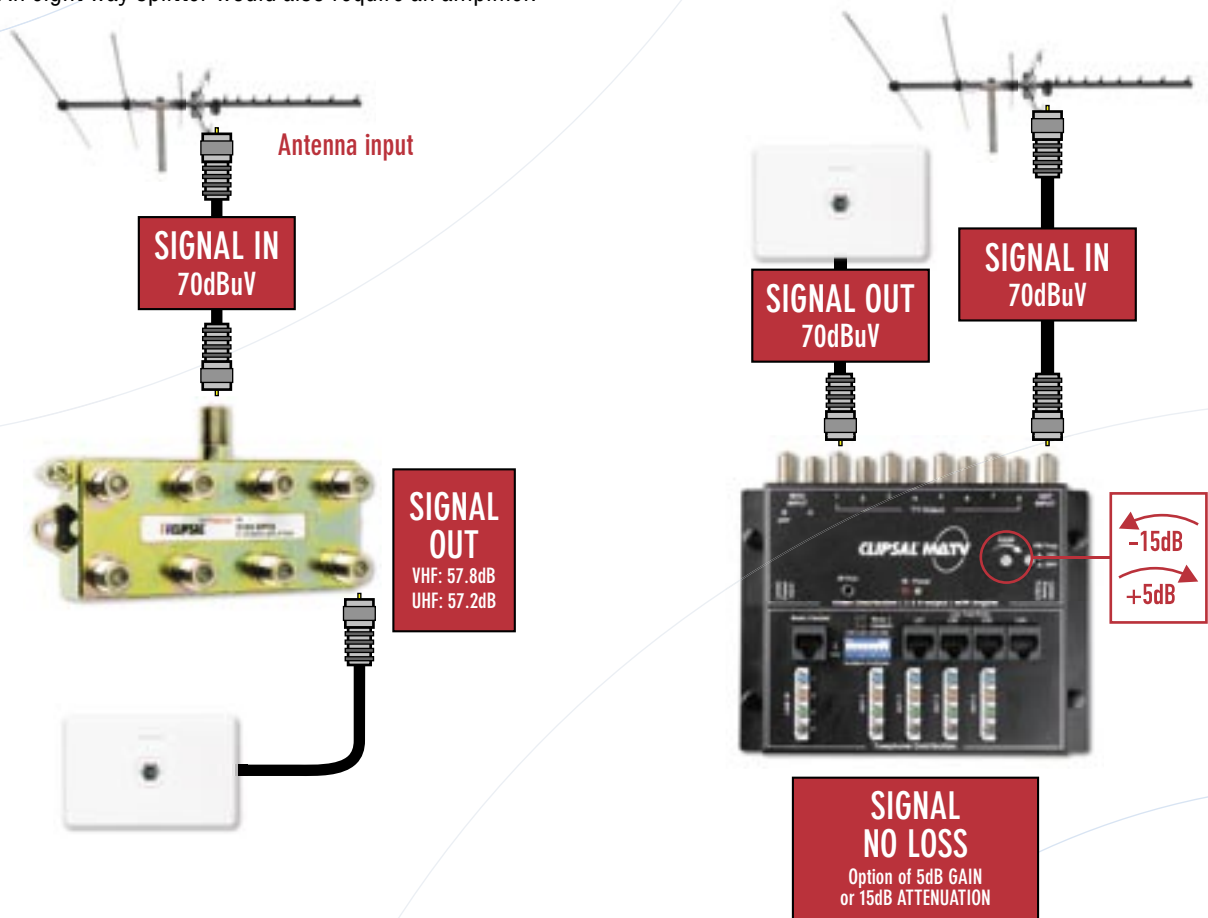

Frequency	2 Way	3 Way	4 Way	6 Way	8 Way
46-470MHz <b>VHF</b>	< 3.5dB	< 6.1dB	< 7.5dB	< 10.2dB	< 11.2dB
471-860MHz <b>UHF</b>	< 4.4dB	< 6.3dB	< 7.8dB	< 10.7dB	< 11.8dB

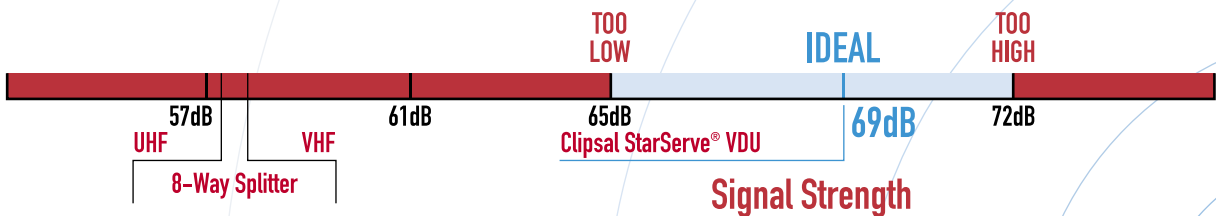



## Choosing the Right Antenna

---

Developments in TV Across Australia will include the most up to date planning and implementation of all analogue and digital broadcast TV services throughout the country.

It will also include an antenna selection for each transmitter, which makes choosing the right antenna a very simple exercise. You cannot afford to be without this great reference guide.

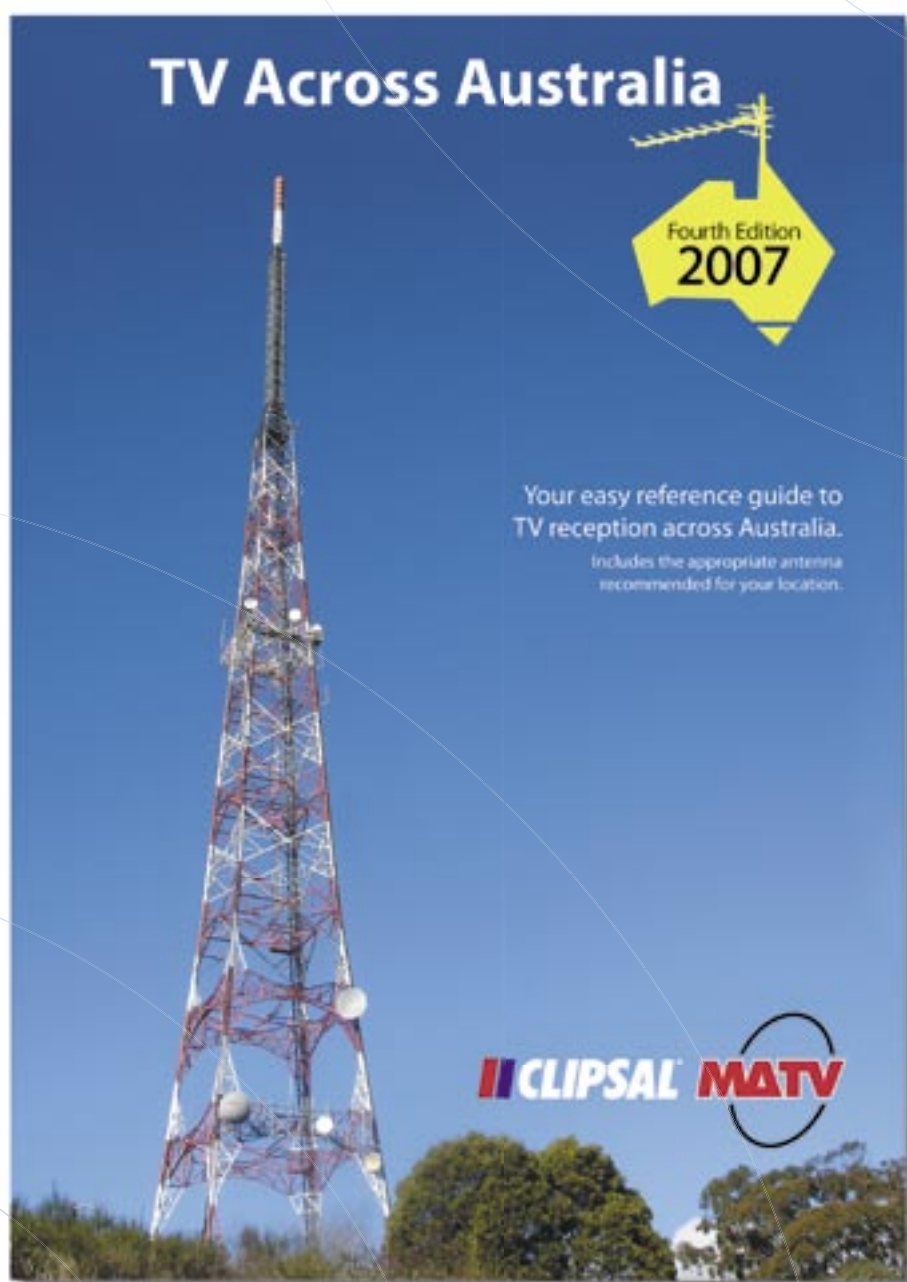

## 3105ABEN

## Slimline Enclosure



The size of the enclosure is determined by the number of cables and active equipment required inside the enclosure. Choose an appropriate enclosure to accommodate the cabling required for the installation.

## Features

---

- designed to be recessed into 63mm stud walls
- installed at second fix stage
- 1-11 RG6 quad shield coax cables for TV distribution
- 1-8 Category 5e or Category 6 Data cables for structured cabling network
- 1-4 Incoming telephone Lines
- 1-8 Category 5e or category 6 data cables for telephone lines
- 1 x 4 port ADSL switch / modem router (Netgear product number DG834)
- cut-out template provided.

## Specifications

---

Dimensions: 269mm wide x 383mm high x 84mm deep

Cut out size: 220mm wide x 360mm high

## 8000LEN

## Lite Sized Enclosure



8000LEN Enclosure



8000LENFK Enclosure Flushing Kit

The size of the enclosure is determined by the number of cables and active equipment required inside the enclosure. Choose an appropriate enclosure to accommodate the cabling required for the installation.

## Features

- small enclosure to suit TV and / or telephone distribution
- 1-11 RG6 quad shield coax cables for TV distribution
- 1-8 Category 5e or Category 6 data cables for telephone distribution
- 1-4 incoming telephone lines.

## Specifications

Dimensions: 300mm wide x 200mm high x 145mm deep

Cut out size: 305mm wide x 205mm high

## 8000MEN

## Mid Sized Enclosure



8000MEN Enclosure



8000MENFK Enclosure Flushing Kit

The size of the enclosure is determined by the number of cables and active equipment required inside the enclosure. Choose an appropriate enclosure to accommodate the cabling required for the installation.

## Features

---

- two vertical rails for increased wiring room and more cables
- surface mount
- flushing kit available for recess mount
- 1-11 RG6 quad shield coax cables for TV distribution
- 1-16 Category 5e or Category 6 data cables for structured cabling network
- 1-4 incoming telephone lines
- 1 x 3105ADJB audio distribution junction box for more than four zones of audio distribution.

## Specifications

---

Dimensions: 450mm wide x 415mm high x 145mm deep

Cut out size: 455mm wide x 420mm high

3105PENF

Professional Flush Mount Enclosure

3105PENS

Professional Surface Mount Enclosure



3105PENF Enclosure



3105PENS Enclosure

The size of the enclosure is determined by the number of cables and active equipment required inside the enclosure. Choose an appropriate enclosure to accommodate the cabling required for the installation.

## Features

- choice of first fix or second fix mounting
- suits different thickness' of plaster board: 10mm, 13mm and 16mm
- dual power outlet inside enclosure
- family look – power, C-Bus and Clipsal StarServe® in the same style of enclosure
- 1-21 RG6 quad shield coax cables for TV distribution
- 1-48 Category 5e or Category 6 data cables for structured cabling network
- 1-10 incoming telephone lines
- 1 x 3105ADJB audio distribution junction box for more than four zones of audio distribution.





## Specifications

Dimensions: 465mm wide x 895mm high x 113mm deep

Cut out size: 470mm wide x 900mm high



### Video Distribution Units

3105VDU38IRT	3105VDU24T	8072/6VHP	8073/8VHPIR
			

#### Distribution

The VDU distributes digital and analogue free to air TV signals from the antenna input to all TV outputs on the VDU. This works as a splitter but one of the special features is that the Clipsal VDU is a powered splitter and has no losses from the input to the outputs.

NOTE: The Clipsal StarServe® VDU is classed as one TV point when choosing an antenna.

#### Variable Gain Control

-15db +5db

The Clipsal StarServe® VDU has a variable gain control to make it easy to adjust for the ideal signal strength and best possible picture. The variable gain control can amplify the incoming signal by 5dBuV or decrease the signal strength by 15dBuV. This feature of the Clipsal StarServe® VDU makes installation easy.



#### Selectable FM Trap

The selectable FM trap is a feature that is built in to the Clipsal StarServe® VDU. FM frequencies can cause interference with other TV frequencies and need to be removed from the distribution system. This can be done with the push of a button on the Clipsal StarServe® VDU.



#### Combination VDU

A combination VDU has been designed to suit the recessed slimline enclosures required in today's markets. These VDUs combine the features of the TV cabling and the connection of the telephone, security system and ADSL services to create a neat, compact solution.

These are entry level solutions and are set and forget products as there is no patching required for a basic setup.

The telephone card can accept one to four incoming telephone lines and distribute up to four locations for each line. The telephone lines can be expanded by jumpering from one to another.

In other words, one incoming line can be expanded to 16 outlets and two incoming lines can be expanded to up to eight outputs per line.

There is a Mode 3 socket for the connection of a security system built into the telephone card.

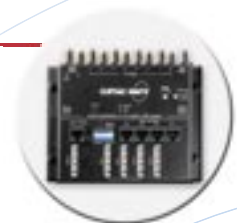





## Modulated Inputs

The modulated inputs on the Clipsal StarServe® VDU are designed for the connection of a modulator to the VDU. This enables the distribution of other devices such as a DVD player, VCR, Subscription TV decoder or surveillance camera to all TV outputs on the VDU.

There are two types of VDU modulated inputs:

### 3105VDU24T & 8072/6VHP

The modulated inputs on the 3105VDU24T and 8072/6VHP are designed for the connection of a modulator to distribute devices such as Subscription TV decoders, DVD players, VCRs etc from one central location to all outputs on the VDU.

The VDU can be powered remotely from this modulated input over the coax cable.

The 3105VDU24T and 8072/6VHP have no IR control of these devices.



### 3105VDU38IRT & 8073/8VHPIR

There are two modulated inputs on these models that allow for the distribution of devices to all TV outputs.

**Modulator Input A** is designed for the connection of a modulator to distribute devices that do not require IR control such as surveillance cameras. This modulator input cannot be used to power the VDU.

**Modulator Input B** is designed for the distribution of devices such as Subscription TV decoders, DVD players, VCRs etc from one central location to all outputs on the VDU with the potential of IR remote control of these devices from other rooms. This modulated input can be used to remotely power the VDU.

These models have an IR engine built into the VDU to enable the IR control of devices from remote locations with the addition of a IR compatible modulator, IR emitter leads and IR targets.



## Power Output

The power output has been designed to power an external device such as a switch/modem router that uses the same 12V dc power plug at the VDU.

This feature was built to accommodate a fully working system that does not require power inside the enclosure which houses the active equipment.

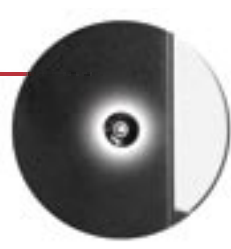

3105VDU38IRT

Infrared Video and Telephone Distribution Unit



Modulator input 'A' for the distribution of devices such as surveillance cameras via a modulator to all TV outputs of the VDU (Modulator sold separately)

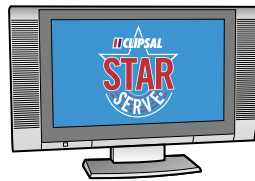

Distributes digital ready TV to eight locations of your choice

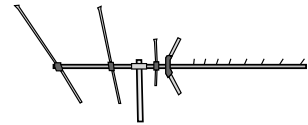

Antenna input

INPUT A has no Infrared control

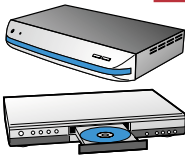

Modulator input 'B' for the distribution of subscription TV, DVD, video via a modulator (Modulator sold separately)

12Vdc power input

IR expansion port: Allows infrared connectivity from one VDU to another

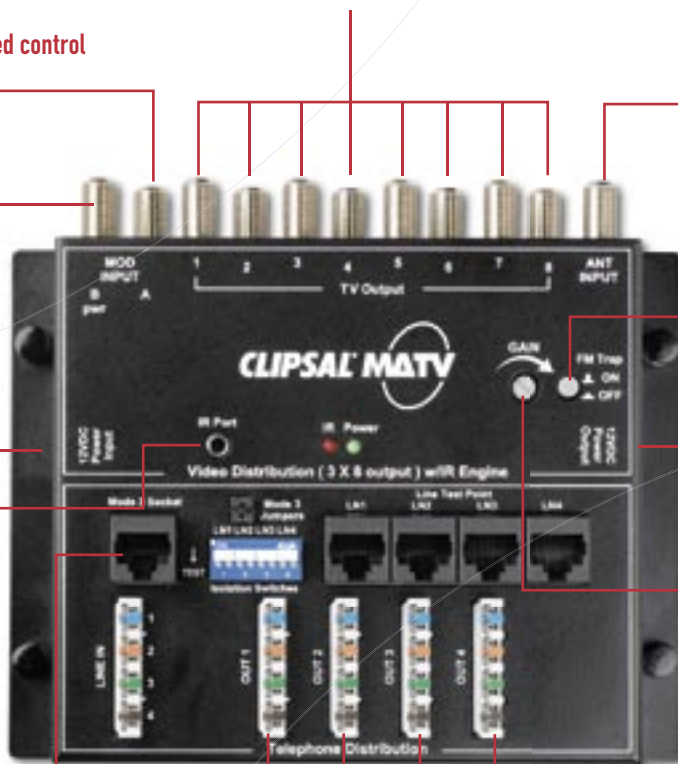

Has a selectable FM trap for filtering out unwanted signals

12Vdc power output for switch modem routers

Variable gain control for adjusting output signal strength to optimum levels

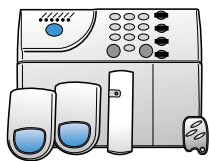

Has a security connection for your security system alarm dialler

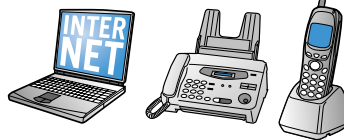

Distributes four telephone, internet or fax lines up to four locations for each line Telephone distribution only, NOT DATA

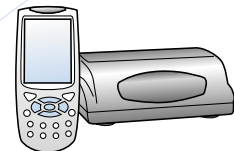

Enables the user to remotely control subscription TV, DVDs etc from another room in conjunction with the Clipsal IR products

Suitable for ALL Clipsal StarServe® Enclosures



3105VDU24T

Video and Telephone Distribution Unit

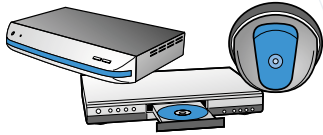

Modulator input for the distribution of other services such as subscription TV, DVD, video, surveillance cameras etc. via a modulator to all TV outputs of the VDU  
(Modulator sold separately)

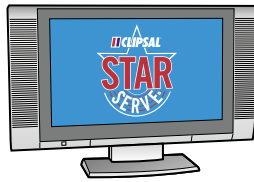

Distributes digital ready TV to four locations of your choice

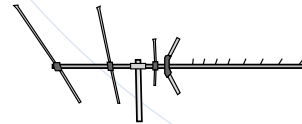

Antenna input

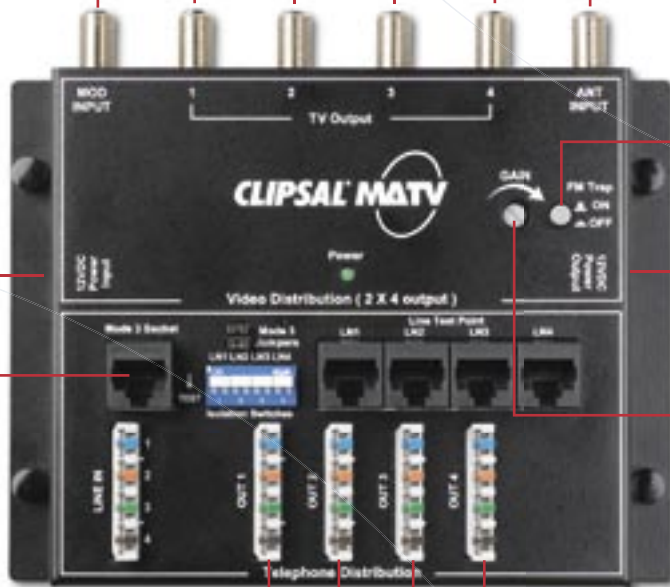

Has a selectable FM trap for filtering out unwanted signals

12Vdc power output for switch modem routers

Variable gain control for adjusting output signal strength to optimum levels

12Vdc power input

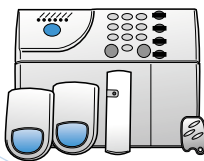

Has a security connection for your security system alarm dialler



Distributes four telephone, internet or fax lines up to four locations for each line  
Telephone distribution only, NOT DATA

Suitable for ALL Clipsal StarServe® Enclosures

PLEASE NOTE: this model DOES NOT support the remote control of devices in other rooms



## SECTION 3

# Clipsal StarServe® Product Introduction

### 8073/8VHPIR

### Video Hub

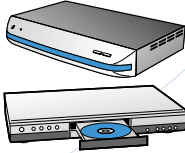

Modulator input 'B' for the distribution of subscription TV, DVD, video via a modulator

(Modulator sold separately)

IR expansion port: allows infrared connectivity from one VDU to another

12Vdc power input

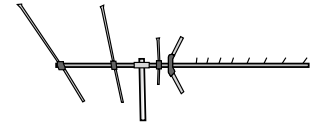

Antenna input

Has a selectable FM trap for filtering out unwanted signals



Modulator input 'A' for the distribution of devices such as surveillance cameras via a modulator to all TV outputs of the VDU  
(Modulator sold separately)

INPUT A has no infrared control

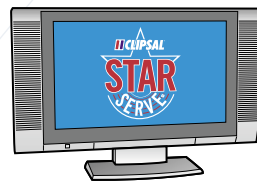

Distributes digital ready TV to eight locations of your choice

Variable gain control for adjusting output signal strength to optimum levels

Suitable for 3105PENF, 3105PENS, 8000MEN and 8000LEN Enclosures



8072/6VHP

Video Hub

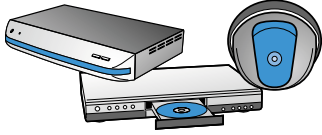

Modulator input for the distribution of other services such as subscription TV, DVD, video, surveillance cameras etc. via a modulator to all TV outputs of the VDU  
(Modulator sold separately)

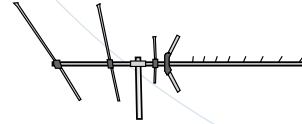

Antenna input

12Vdc power input



Variable gain control for adjusting output signal strength to optimum levels

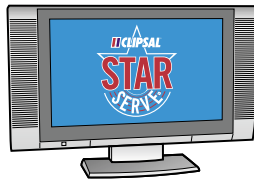

Distributes digital ready TV to six locations of your choice

Suitable for 3105PENF, 3105PENS, 8000MEN and 8000LEN Enclosures

## Clipsal StarServe® VDU Power Options

### Remote Powering of the VDU - Modulator

The modulator can be used to power the VDU instead of the power injector. You connect the modulator to the “MOD INPUT B” of the VDU.

You must make sure that the VDU is disconnected from any other means of power before you remotely power the VDU.

Simply slide the remote power switch from OFF to ON. This will power the VDU from the modulator.

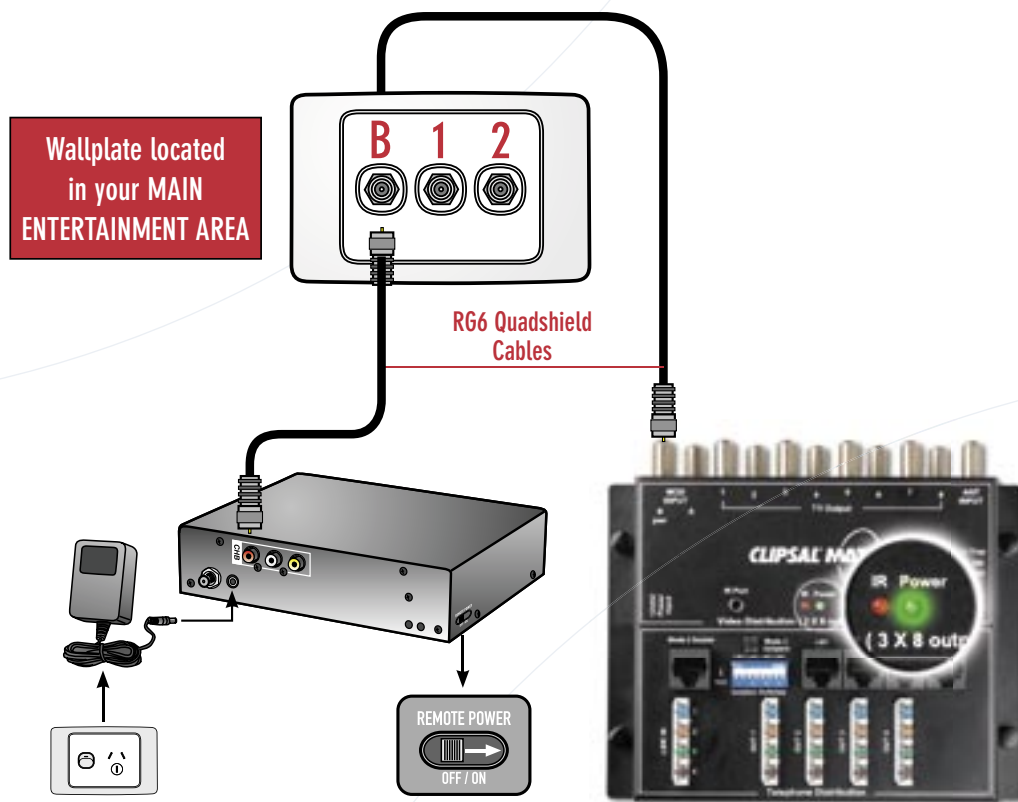

**DO NOT** connect a power supply to the VDU when it is being powered via the modulator.



The IR system will only work when the remote power switch is in the ON position.



## Power Injector

The power injector is used to remotely power the VDU when a modulator is not installed into the system. The power injector is connected to the modulator return path “MOD INPUT B” connection on the wall plate in the main entertainment area.

**Connect the power injector to “MOD INPUT B” on the 3105VDU38IRT and 8073/8VHPIR and to “MOD” on the 3105VDU24T and 8072/6VHP.**

The 12 Volt DC plug pack is plugged in to the power injector. The plug pack is then plugged into a power point and turned on. The green power LED on the VDU will illuminate when the power is turned ON.

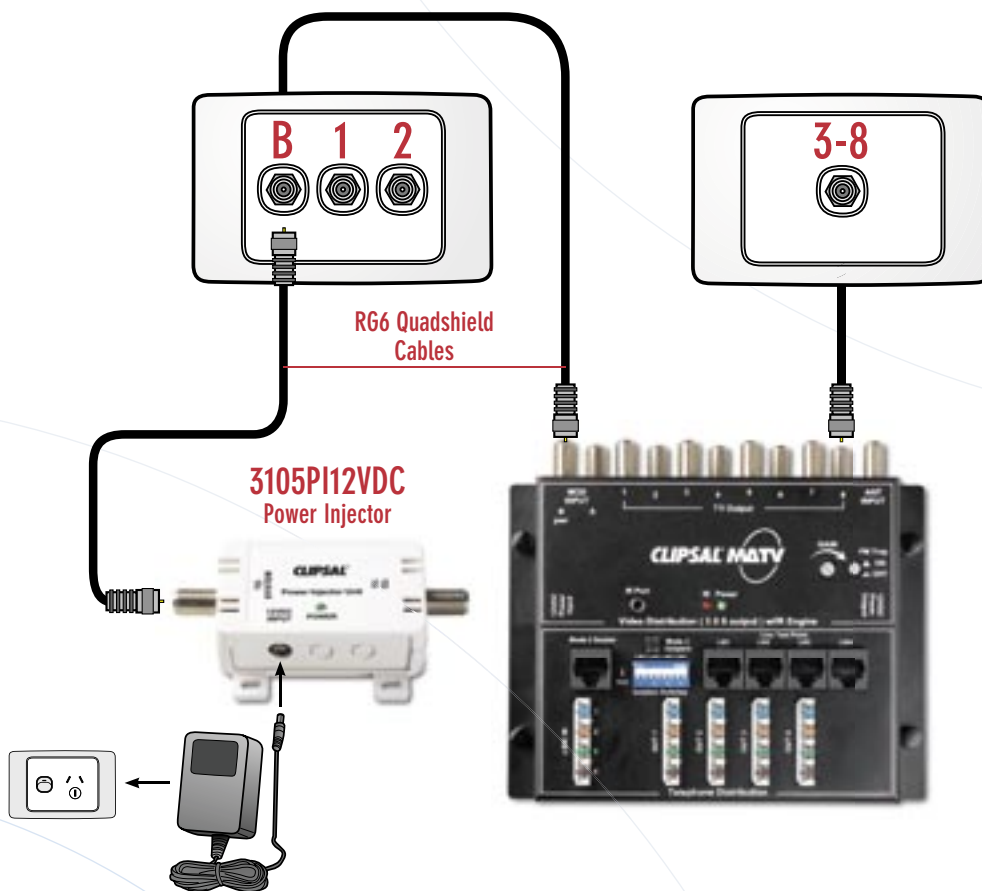

**DO NOT connect the power injector to any TV output on the VDU.  
DO NOT connect the modulator to the “MOD INPUT A”.**

**SECTION 3**

**Clipsal StarServe® Product Introduction**

**Local Powering of the VDU - Plug Pack**

The plug pack can be directly plugged into the VDU power input when power is available inside the Clipsal StarServe® enclosure.

The green power LED on the VDU will illuminate when the power is turned ON.



 **When connecting a modulator, DO NOT SWITCH THE REMOTE POWER SWITCH TO ON, as this may damage the VDU. DO NOT CONNECT THE MODULATOR TO THE "MOD INPUT A".**





## Clipsal Digital Ready Antennas

Clipsal have engineered an antenna range that is easy to install and offers high performance. All Clipsal antennas are digital ready and analogue compatible, ensuring that your television requirements are covered for today and tomorrow.

The Clipsal Antenna Range has been designed with you, the installer, in mind. Clipsal are making your job easier by providing you with a product that can simply be taken out of the pack and installed with minimal assembly. This saves you time and money where it counts the most, on site. Clipsal have also made antennas safe to install by crimping and machining all ends of the elements and directors, drastically minimising the possibility of cuts and scratches.



To obtain a brochure or for further information call **1800 728 728**



## Modulators

Modulators connect active devices such as your subscription TV decoder and DVD player so that they can be distributed to all other TV outlets connected to Clipsal StarServe®. The modulator converts video composite signals into analogue UHF frequencies. Your TV or tuner must be able to receive analogue frequencies for modulated channels.

### 8071VMP – Single Channel Modulator

Single channel modulators will distribute one device to any TV connected to Clipsal StarServe®. A single channel modulator is generally used for the distribution of surveillance cameras at the front door.

### 8072VMPIR – 2 Channel Modulator

Two channel modulators will distribute two devices such as subscription TV and a DVD player. This model is IR enabled to allow for the remote controlling of devices in other rooms over the coax cable. Up to four devices can be controlled using dual emitter leads.

### 8074VMPIR – 4 Channel Modulator

Four channel modulators will distribute four devices such as subscription TV, DVD, video and a digital set top box to all outlets connected to Clipsal StarServe®.

This model is IR enabled to allow for the remote controlling of devices in other rooms over the coax cable. Up to eight devices can be controlled using dual emitter leads.

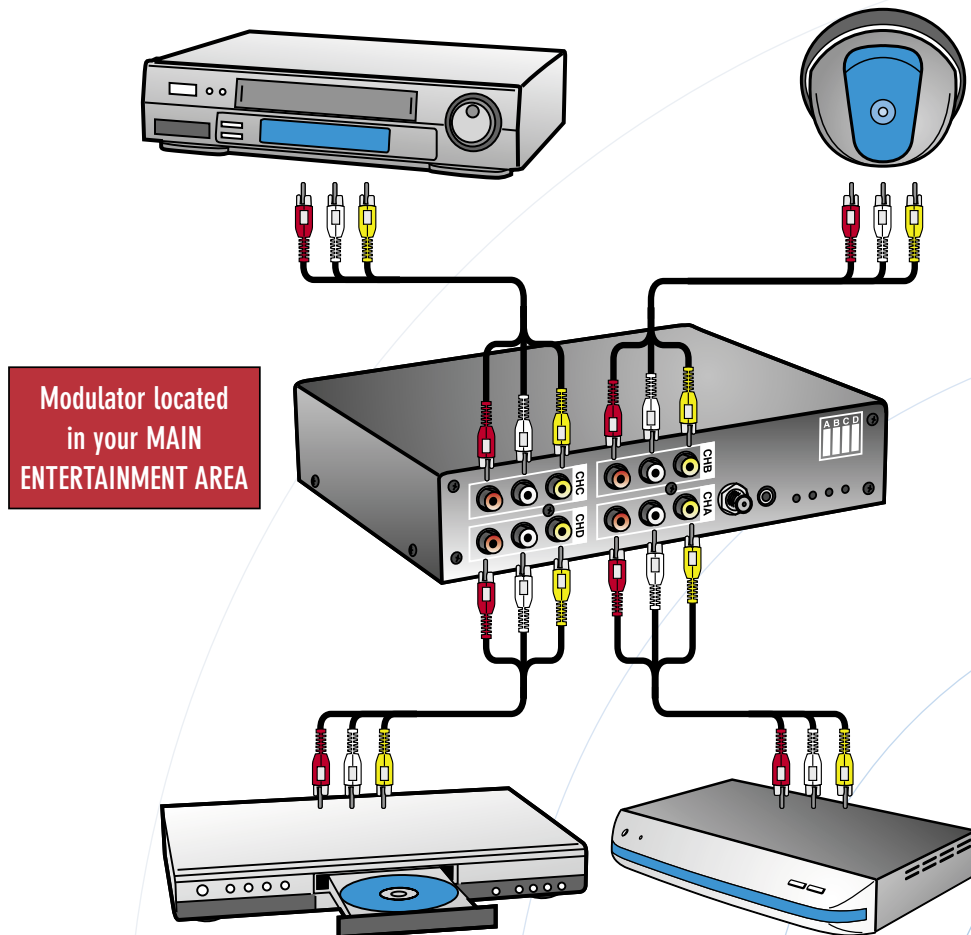

## Emitter Leads

Infrared emitter leads are placed on the IR receiver of the device you wish to control. There is a sticky backing provided on the reverse side of the lead which attaches easily to the device.



**8050LD**  
Single Emitter Lead



**8050/2LD**  
Double Emitter Lead

Connect the leads to the modulator located in the  
MAIN ENTERTAINMENT AREA (the lounge room)

## Infrared Targets

An infrared target is required for EACH ROOM you wish to remotely control devices from. Simply place it in a convenient location either alongside or underneath the TV.



**8050TT**  
Tube Target



**8050TR**  
Infrared Transmitter



**8050FT**  
Flat Target



**8050ST**  
Shelf Target



**8000INJ**  
IR Injector  
(Refer PAGE 30)

The IR target can be connected to any TV outlet in any room.

The 8050TT, 8050ST and 8050FT are connected using the 8000INJ IR injector.

## Patch Panels - Data and Telephone

### Data

Data patch panels are used for the termination of data cables inside the Clipsal StarServe® enclosure.

A data outlet is a Category 5e or 6 cable with a connector terminated onto each end. In essence, it is a high performance extension cord for the connection of two or more computers. A patch lead at either end connects the devices you want to network.

### Telephone

If you require the ability to move telephone lines to different outlets within your home, you can use a telephone patch panel. A data patch panel is required to connect to all field outlets. You can achieve this in two ways:

**OPTION 1:** Use the Clipsal 8052/4RJ45 Telephone Patch Panel with internal connections for four extensions for each line (maximum two lines per patch panel).

**OPTION 2:** Use an eight port patch panel and connect as many lines as you need.

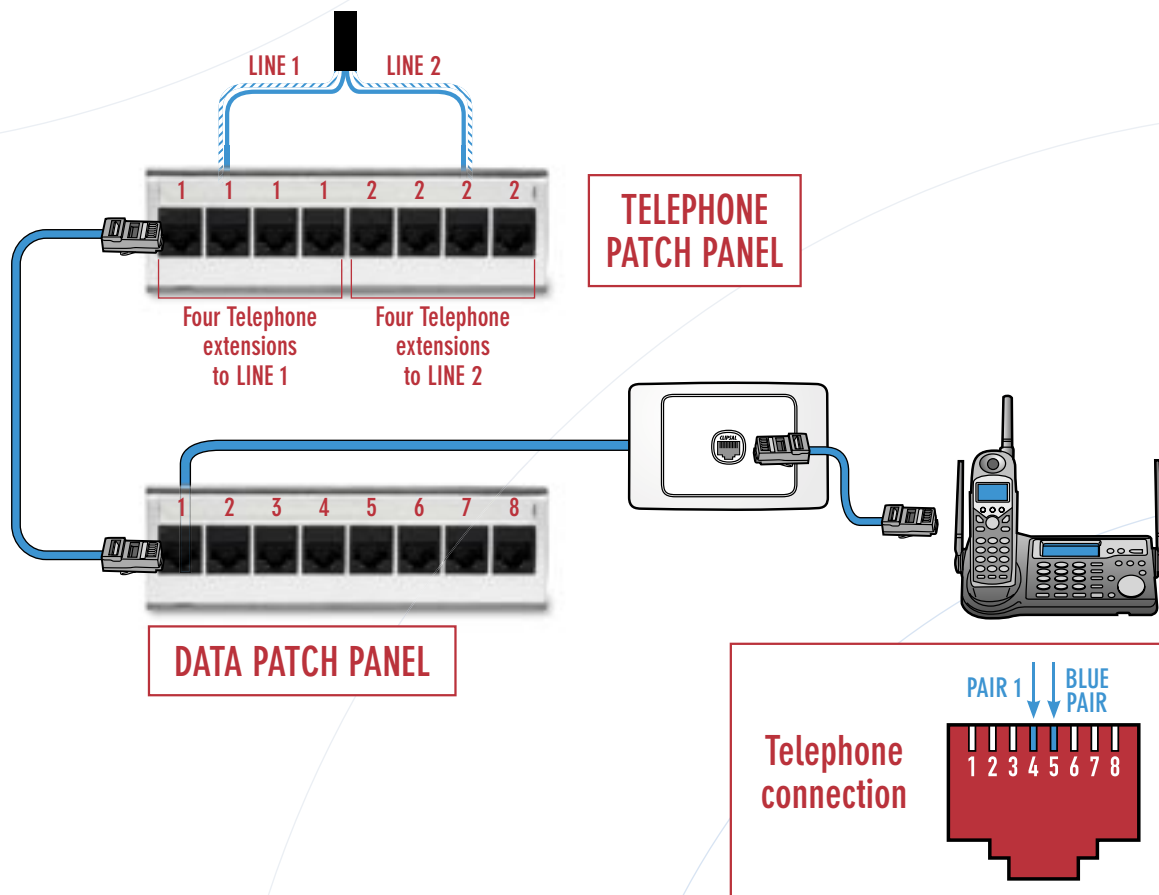



## Switches - Data Patch Panels

A switch connects two or more computers together so that they can communicate with each other.



**95ESW5P**  
5-Port Ethernet Switch



**95ESW8P**  
8-Port Ethernet Switch

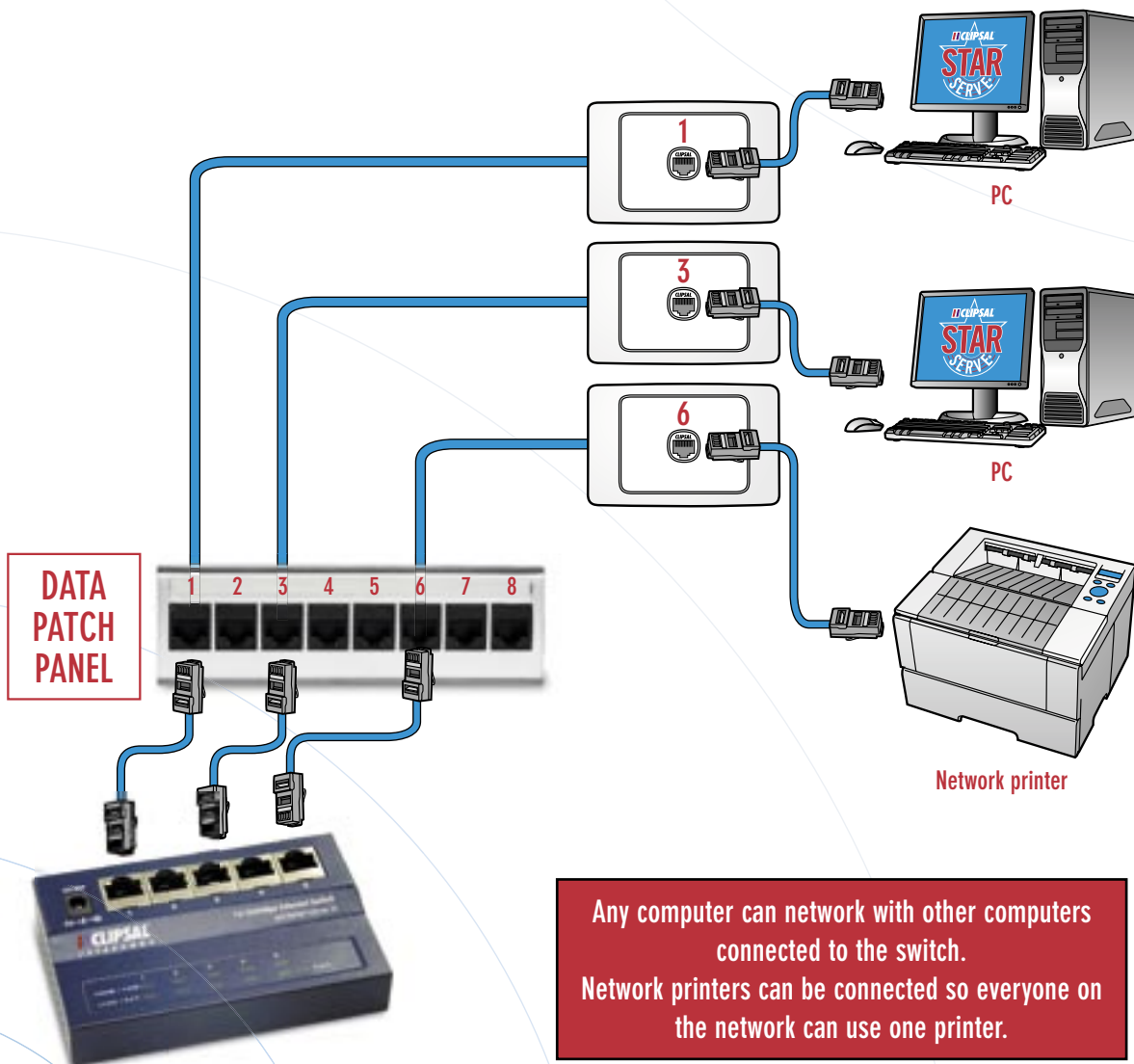

Any computer can network with other computers connected to the switch.  
Network printers can be connected so everyone on the network can use one printer.

## 8001/4EX

## Output Expander

The output expander allows you to increase the number of Clipsal StarServe® outputs without the use of an additional video hub. It consists of one input and four outputs.

Connect an output of your existing video hub to the input of the expander. You will lose the use of an output on the video hub but gain an additional four outputs on the output expander.

You can connect an output expander to each output on a video hub, providing up to 32 outputs from an eight input hub.



## 8000INJ

## IR Injector

The IR injector allows you to insert an IR target anywhere along the RG6 cable feed between the Clipsal StarServe® video hub and the TV. This means a target can be placed away from the TV screen to eliminate interference from the TV or plasma screen.

The IR injector can be used with a tube (**8050TT**), flat (**8050FT**) or shelf (**8050ST**) target.



**8050TT**  
Tube Target



**8050FT**  
Flat Target



**8050ST**  
Shelf Target

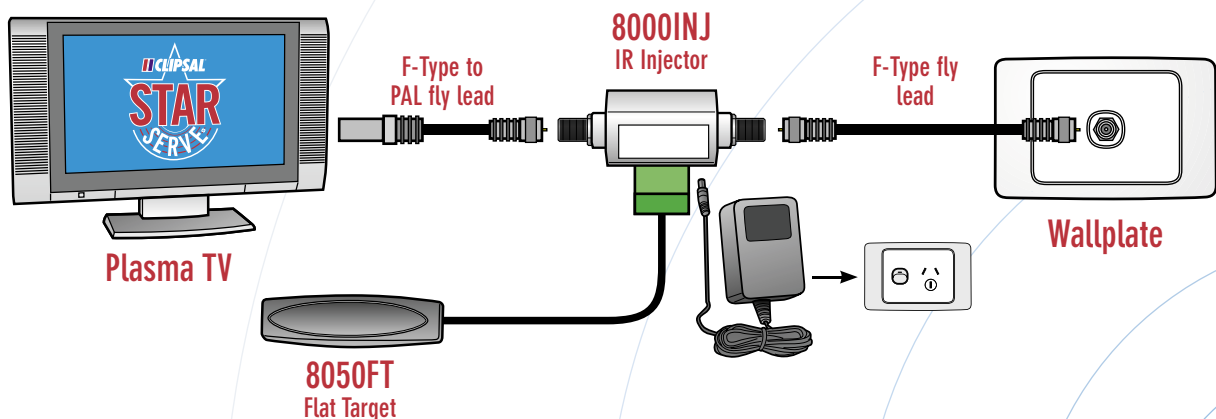

**8000DCB****Coaxial DC Block**

The DC block is used to filter out DC and infrared (IR) control pulses on a Clipsal StarServe® RG6 cable feed. It is inserted in an individual cable feed. It contains a capacitor which allows high frequency video and audio to pass, but blocks DC and low frequency IR.

**8000SS****Surge Suppressor**

The surge suppressor reduces the effects of transient voltages from an antenna. It is installed between the antenna and the video hub antenna input.

**8000AVB****RCA to Cat-5 Cable Adaptor**

This adaptor allows you to transmit standard video and audio signals, as well as DC power over Category 5 or Category 5e cable. An RCA to Category 5 Cable Adaptor is used at each cable end, making it suitable for security camera installations integrated with Clipsal StarServe®.

The 8000AVB has two baluns and one power lead supplied in each pack (one for either end of the cabling network).



## TV Cabling Requirements

All TV cabling is done in **RG6 Quad Shield Coax cable**. The Clipsal Quad Shield coax cable is Foxtel approved. RG6 Quad Shield Coax has excellent shielding against electrical noise, which can affect picture quality.

The use of a top quality coax cable will greatly minimise any call-backs for the electrical contractor.



**2B6Q3B**  
RG6 Quad Shield Coax Cable

## F-Type Connectors

F-Type connectors are the best connectors to use in an MATV installation. F-Type connectors have very low losses and are easy to connect. Clipsal recommend two types of F-Type connectors on a Clipsal StarServe® System, the Radial Crimp **3105RG6F** or the Compression Connector **3105RG6FC50**.



**3105RG6F**  
Radial Crimp



**3105PM-FF**  
F-Type Female Adaptor  
to Male PAL



**3105RG6FC50**  
Compression Connector

To make up good quality fly leads on site, Clipsal recommend the use of F-Type to PAL adaptors.

## MATV Tools Required

To perform a Clipsal StarServe® Installation quickly and effectively you require the right tools for the job.



**3105CS6**  
Cable Stripper to suit  
RG6 Quad Shield



**3105CT611**  
Crimper for Radial Crimp F-Type connection



**3105CT611C**  
Compression tool to suit F-Type compression connectors

## TV Mechs

All TV outlets are to be F-Type – F-Type Connectors (part number **30PFM**). The Clipsal 30PFM is a straight through connector. This connector has excellent electrical performance and minimal losses. This connector allows IR to pass through for the remote control IR engine built into the Clipsal StarServe® VDU.

Failure to use the 30PFM may result in the infrared control to fail.



**30PFM**  
F-Type Connectors

## TV Fly Leads

Clipsal has F-Type to PAL fly leads in its range to suit Clipsal StarServe® installations.

Fly leads are the weakest point in any TV system. Fly leads are subjected to being twisted and tangled with power cords behind TV entertainment units. Using RG6 quad shield coax fly leads will minimise any potential problems occurring and reduce any potential call-backs.

Fly leads can be manufactured on site or purchased as a finished product.



**3105FL318MBQ**  
F-Type to PAL Fly Lead  
(Black)



**3105FL318MWQ**  
F-Type to PAL Fly Lead  
(White)

## Digital Terrestrial Meter

A digital terrestrial meter is used to measure the Signal Strength of a MATV System. This is one of the most important tools you can own, as it will save you lots of time and money. Instead of guessing the antenna direction and signal strength you can accurately align the antenna and measure the signal strength.



**2ANDTM**  
Digital Terrestrial Meter



Conventional TV Cabling

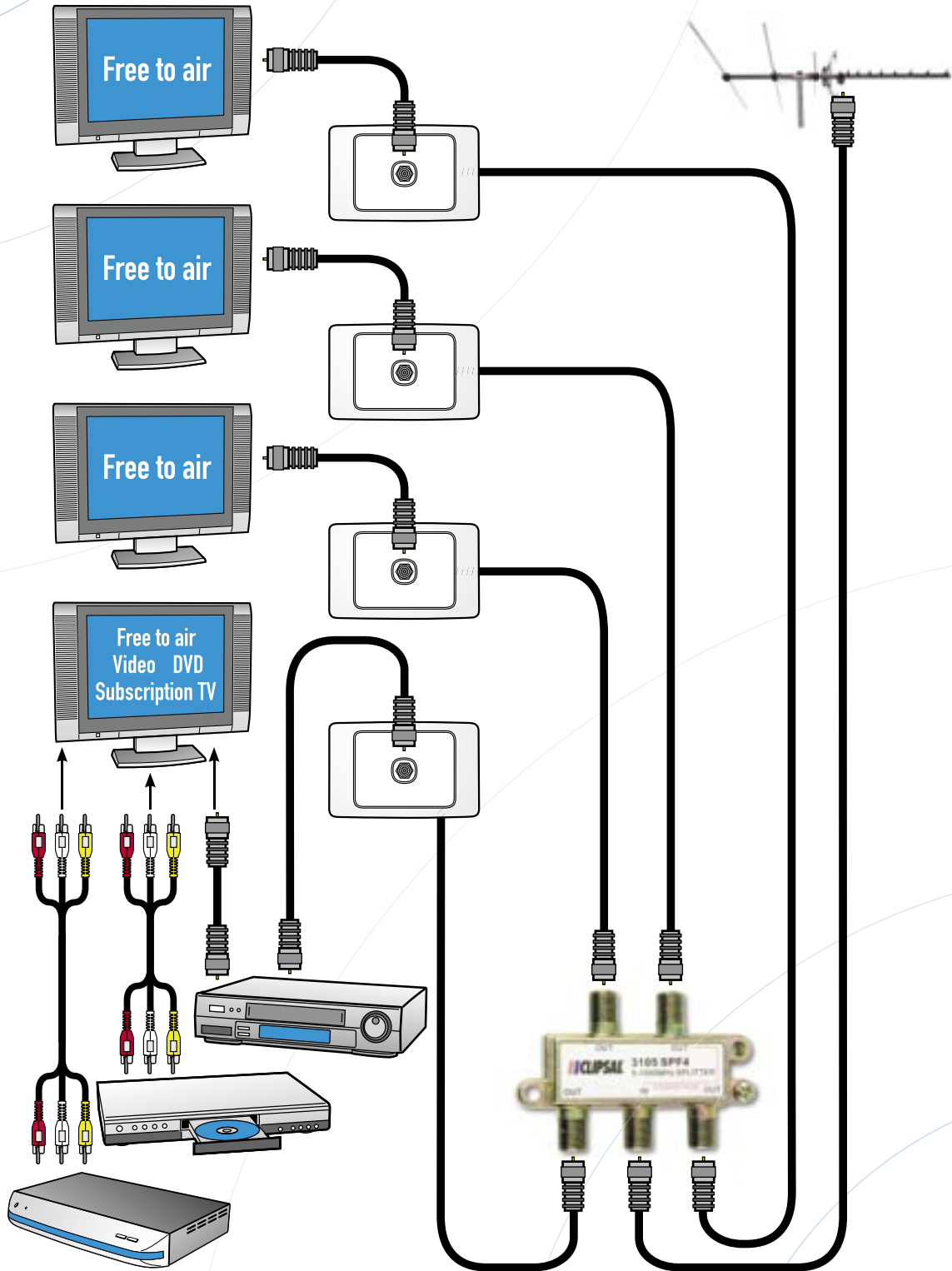

Only one TV can view DVD, subscription TV or video at one time.





Clipsal StarServe® TV Cabling

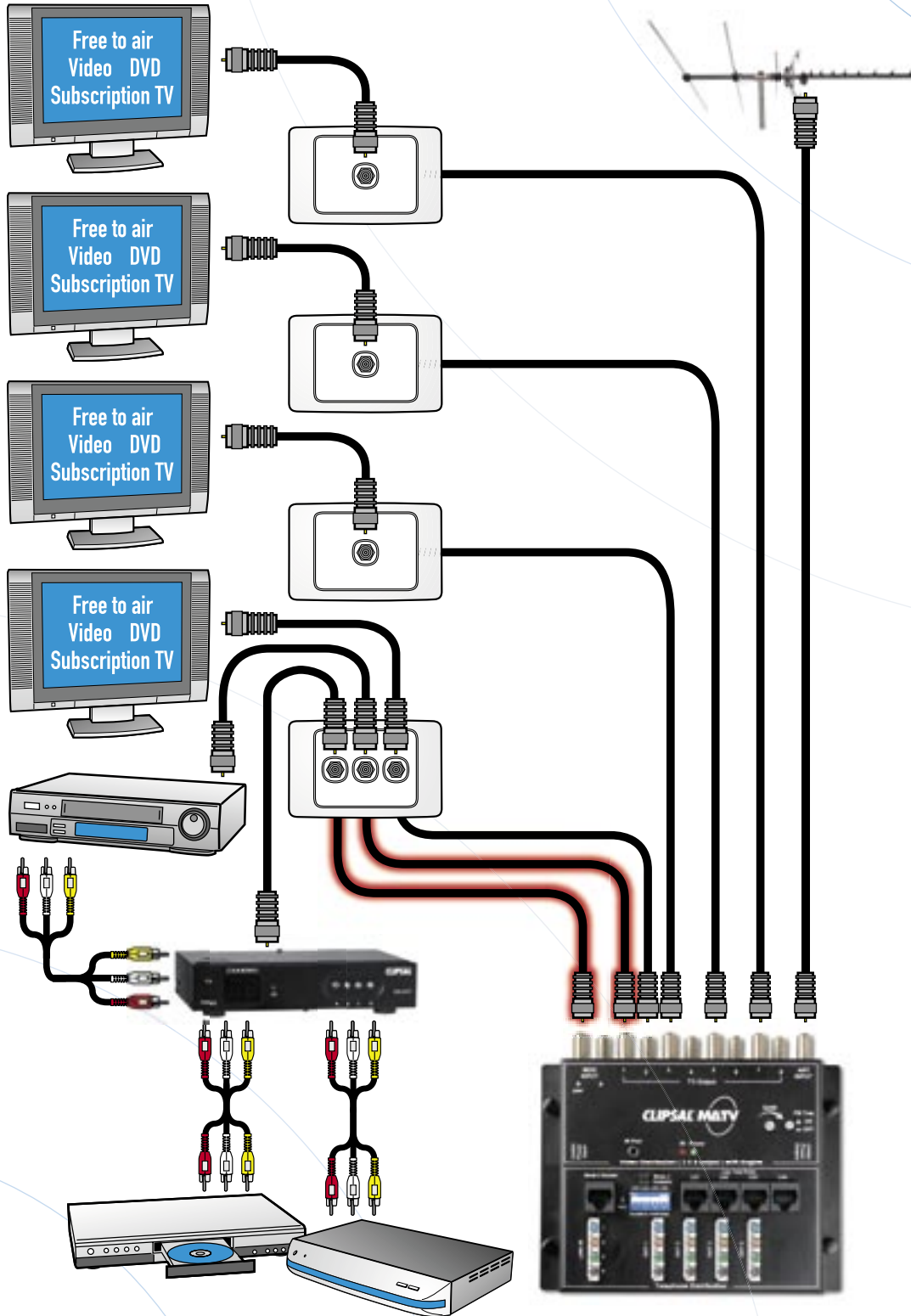

All TVs can view DVD, subscription TV or video at one time.  
Only TWO extra coax cables are required.

# SECTION 4

# Minimum TV Cabling Requirements

3105VDU38IRT

TV Wiring Diagram

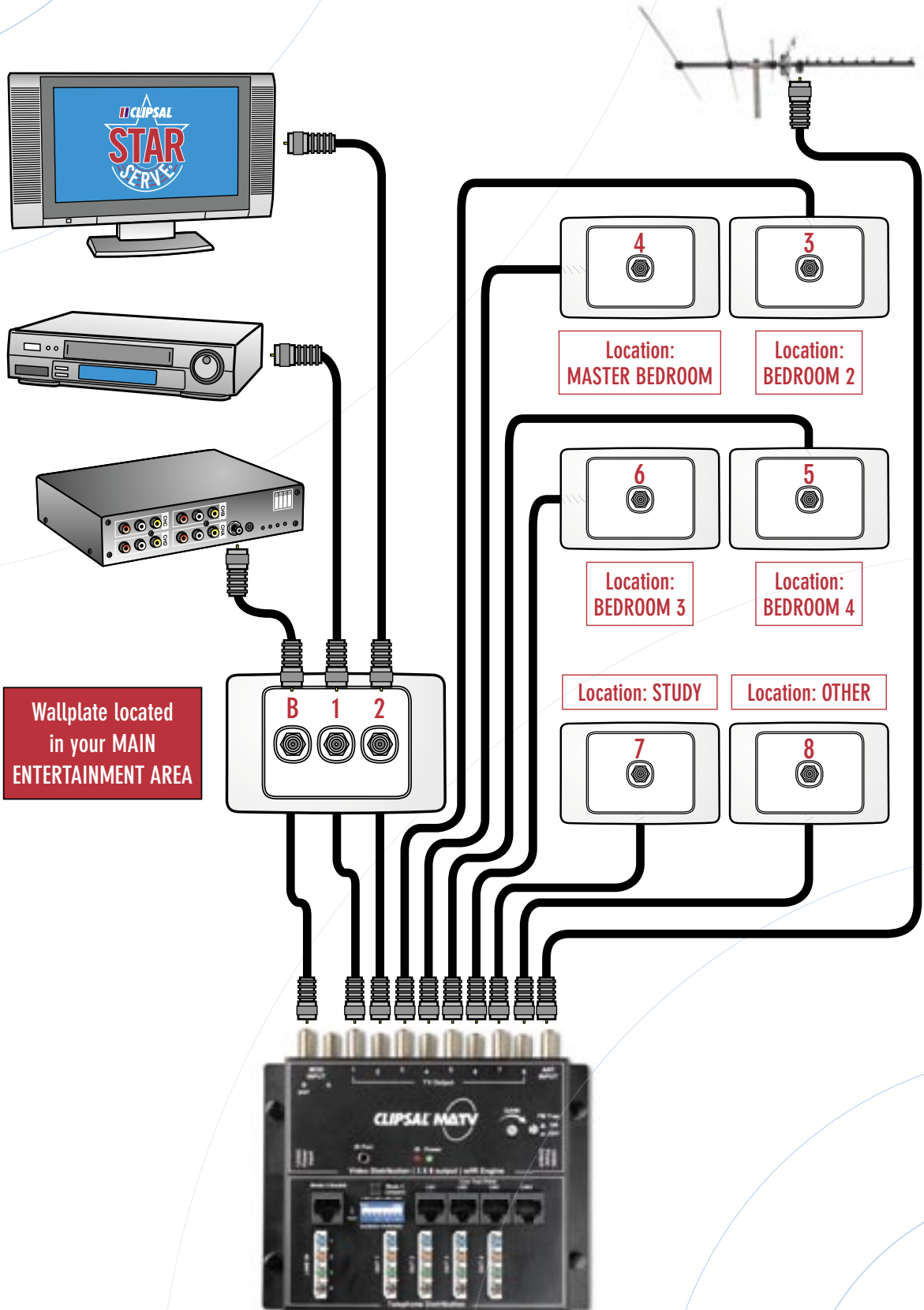

Wallplate located in your MAIN ENTERTAINMENT AREA



3105VDU24T

TV Wiring Diagram

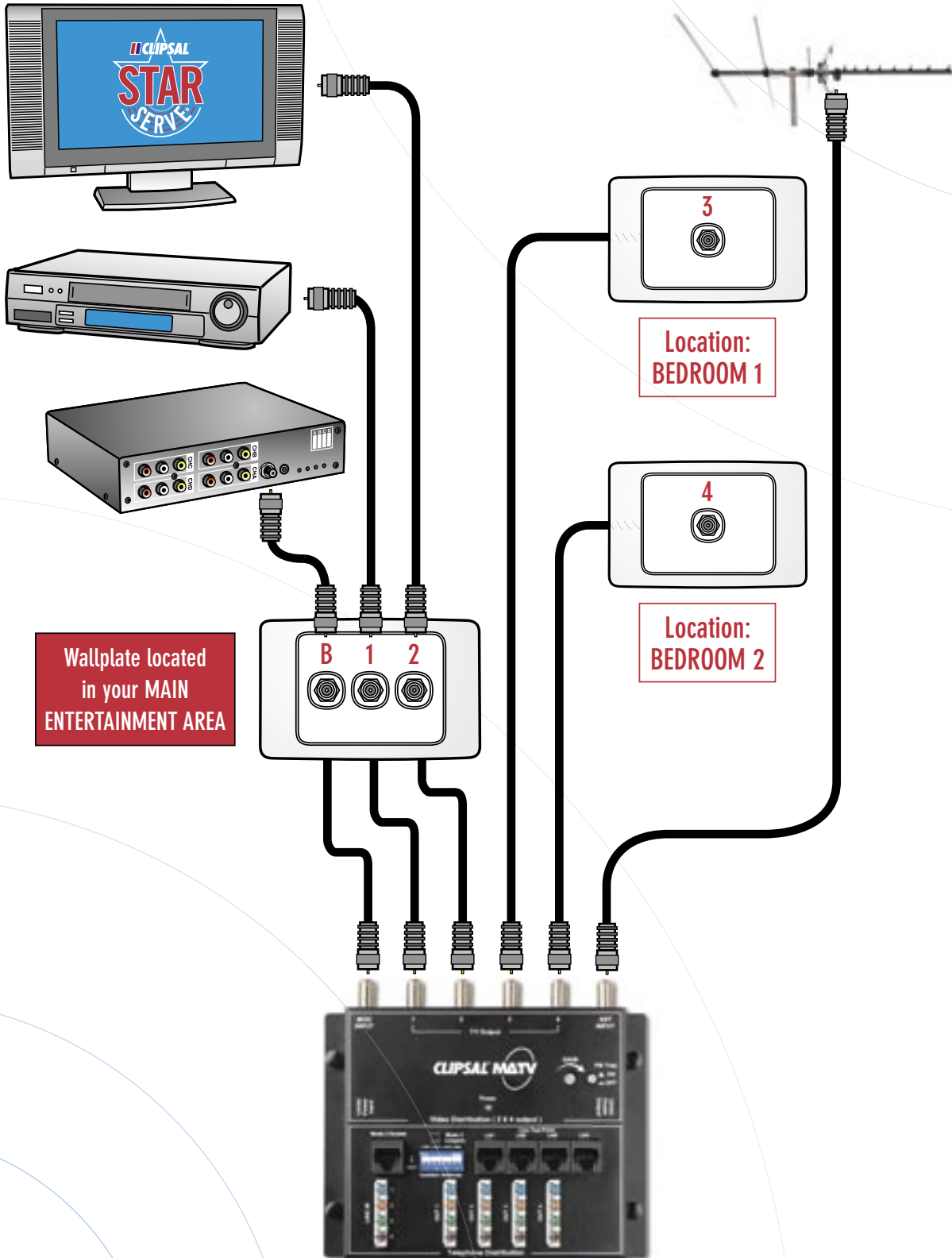

Wallplate located in your MAIN ENTERTAINMENT AREA

Location: BEDROOM 1

Location: BEDROOM 2

# SECTION 4

# Minimum TV Cabling Requirements

## 8073/8VHPIR

## TV Wiring Diagram

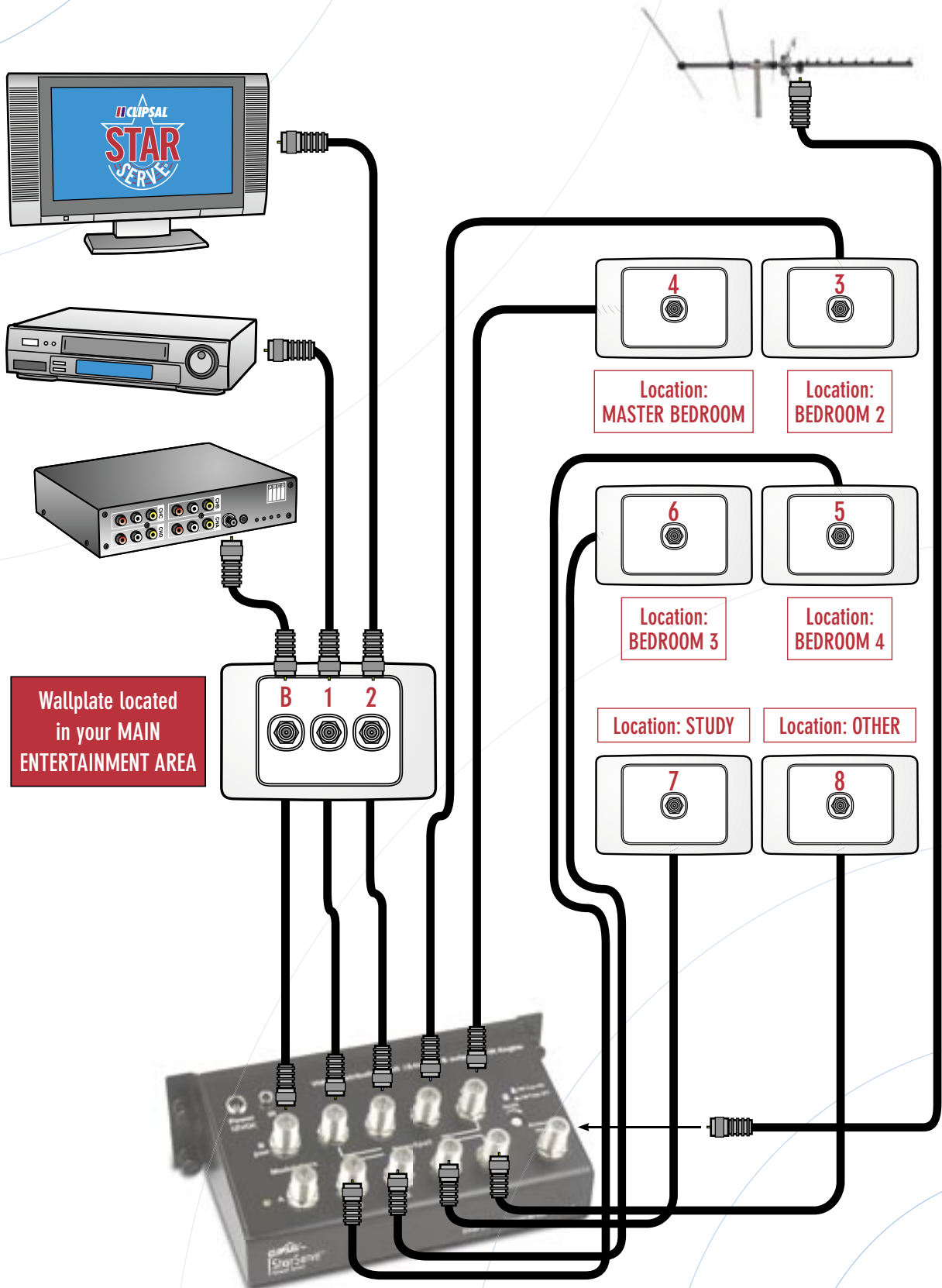

Wallplate located in your MAIN ENTERTAINMENT AREA



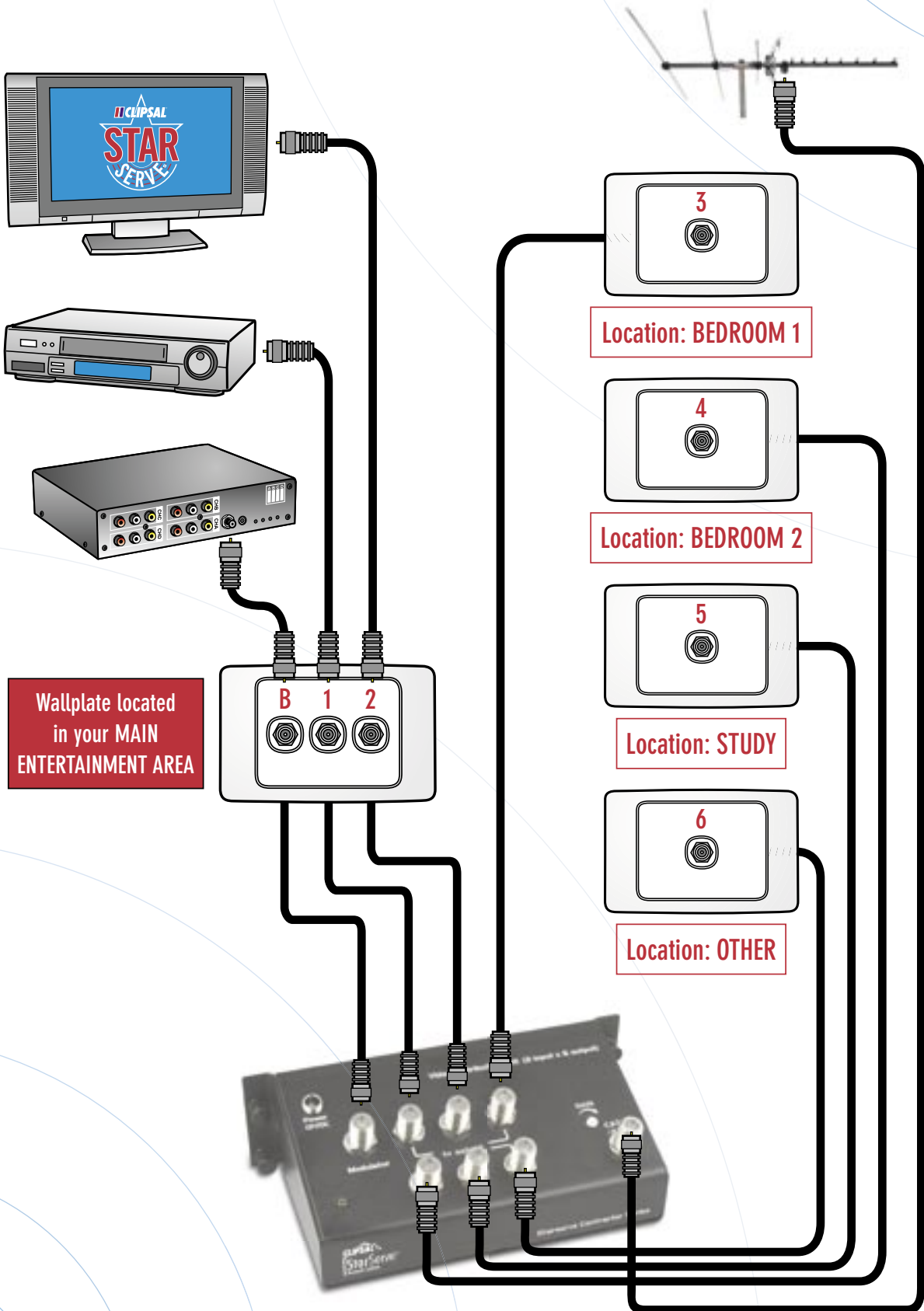

## Antenna Input

The antenna input of the video distribution unit (VDU) has an F-Type connection. The Clipsal StarServe® VDU has built in gain control to enable the optimum signal level to be achieved easily with the turn of a screw.

The range of variable gain control is +5dBuV Gain (**increase**) from incoming signal or –15 dBuV attenuation (**loss**).

The optimum level of signal strength on the output ports of the VDU is 72dBuV.

This means that a minimum signal level of 69 dBuV is required at the antenna input (a small margin is allowed for variation between signals).

The maximum signal level that can be connected to the antenna input is 89dBuV.

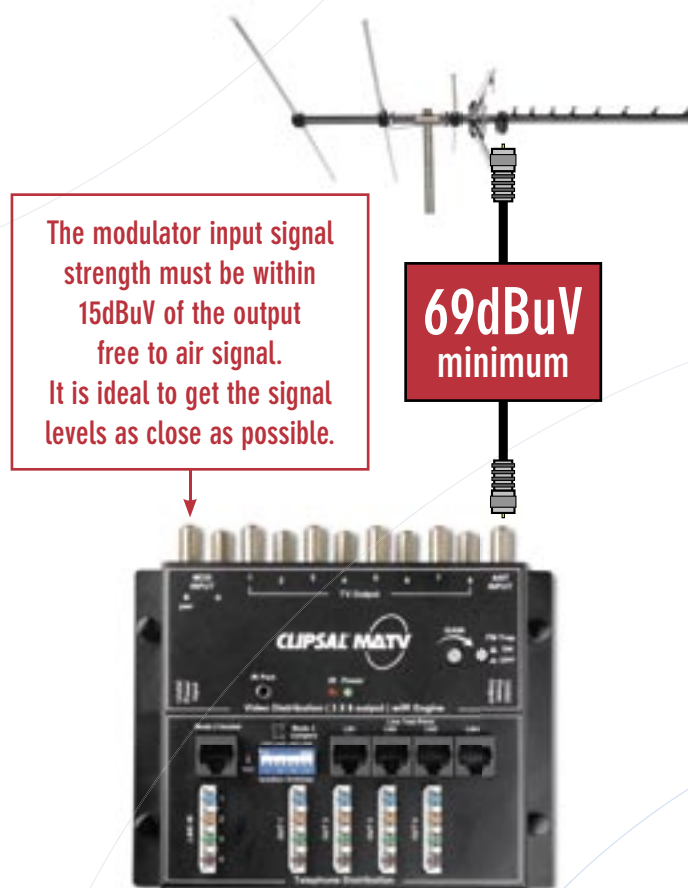

### Step 1

Measure the incoming signal from the antenna. If the signal is between **69 - 89 dBuV**, you can connect to the Clipsal StarServe® VDU via the antenna input. If the signal strength is **below 69dBuV**, you will need to **EITHER** replace the antenna with a larger model **OR** use an amplifier to increase the signal strength.

If the signal strength is **over 89dBuV**, you will have to attenuate the signal via a drop tap.

### Step 2

Measure the signal strength from the VDU output. Adjust the variable gain control until you reach **72dBuV**.



## Antenna Input – Using an amplifier with the Clipsal StarServe® VDU

If you are using an amplifier with Clipsal StarServe® Video Distribution you must follow these strict requirements otherwise you may cause damage to the VDU.

A DC block must be used on the antenna input to the VDU. This will stop any power being supplied to the VDU that can cause damage to the VDU. The masthead amplifier must be powered before the connection to the DC block.

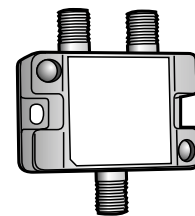
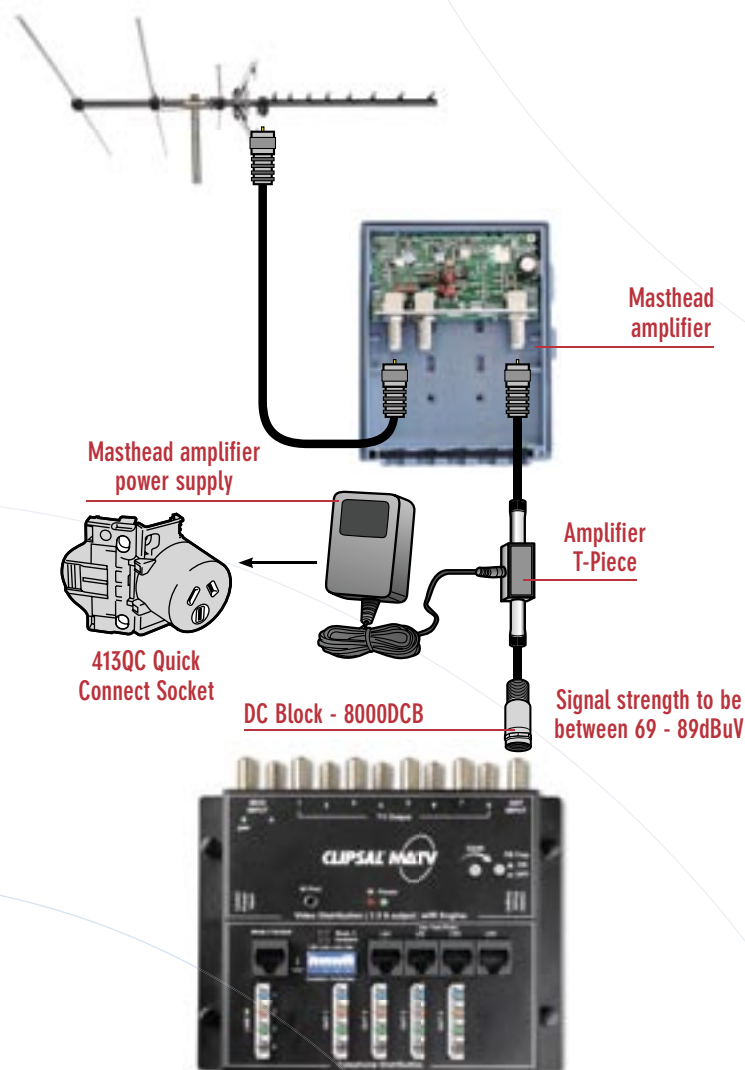

Note: If the incoming signal strength is too high then a drop tap may be used to attenuate the signal strength to achieve the desired level 69 – 89dBuV.

### Step 1

Measure the incoming signal from the amplifier. If the signal is between **69 - 89 dBuV**, you can connect to the Clipsal StarServe® VDU via the antenna input.

If the signal strength is **over 89dBuV**, you will have to attenuate the signal via a drop tap.

### Step 2

Measure the signal strength from the VDU output. Adjust the variable gain control until you reach **72dBuV**.

## Antenna Outputs

The Clipsal StarServe® Video Distribution Unit (VDU) has either four, six or eight output ports depending on the model used.

MODEL	3105VDU24T	3105VDU38IRT	8072/6VHP	8073/8VHPIR
OUTPUTS	4	8	6	8

These output ports are connected to devices such as TVs, video recorders, personal video recorders and digital set top decoders. In fact any device that requires an antenna input connection could be connected to these outputs.

Each output of the VDU will have the same signal strength.

For optimum performance set the VDU output signal strength to 72dBuV.

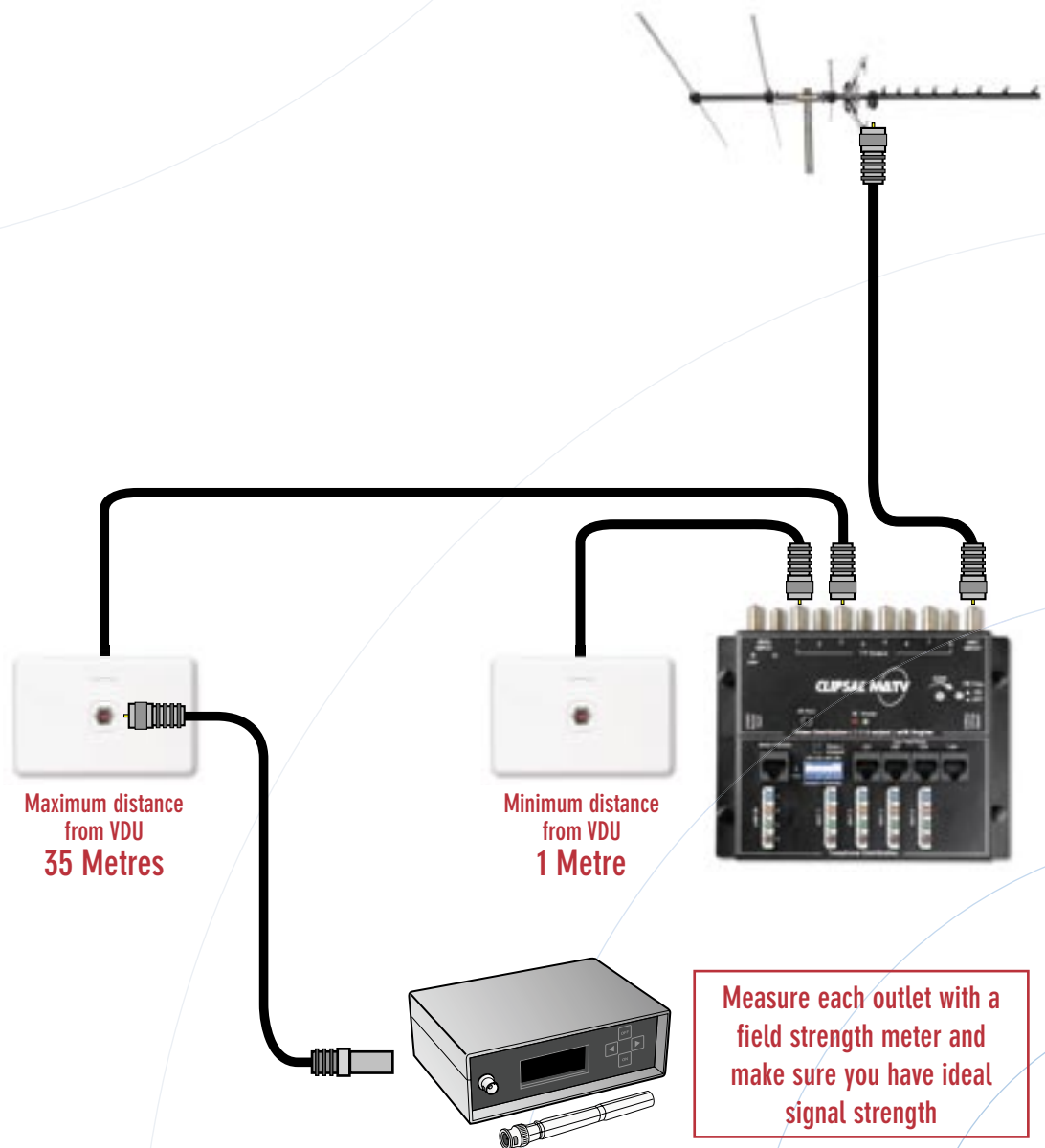

## Modulator Input B - Distribution of Devices

“MOD INPUT B” is used for powering the VDU remotely. This feature means that no power is required at the VDU for TV distribution.

“MOD INPUT B” is also used for the distribution of devices such as subscription TV, DVD, and videos etc. to all of the outputs of the VDU. “MOD INPUT B” is also used as the return path for the IR control of the devices that are being distributed.

A modulator is connected to “MOD INPUT B” via a RG6 Quad Shield Coax Cable. Refer to the modulator diagram for connections. The devices are connected to the modulator via the RCA connections.

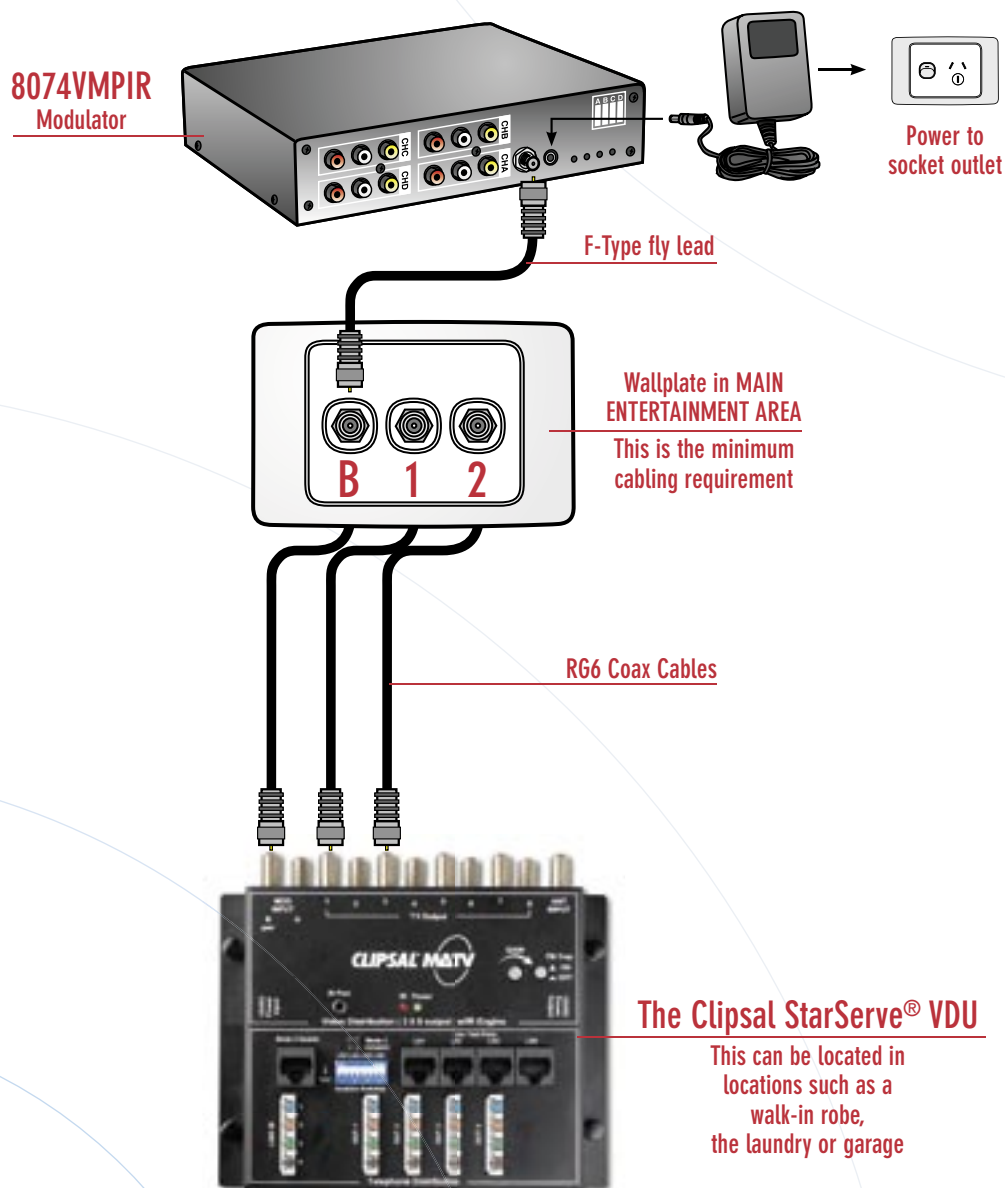

## Setup of the Modulator

The back of the modulator has four RCA inputs for active devices such as subscription TV decoders, DVDs, DVRs etc. The CH refers to the modulator channel input. The input is indicated on the front of the modulator by the letters A – B – C – D.

The Modulator is located in the same area as your DVD, subscription TV decoder and video.

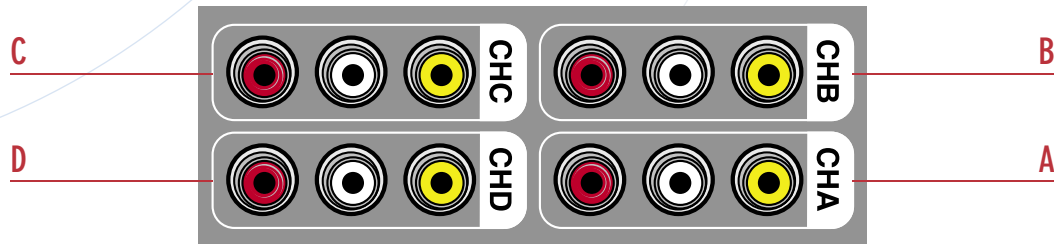

Use the UP and DOWN push buttons to select the UHF channel required

### STEP 2

The screen will indicate the UHF channel the selected input will be broadcast on

Available channels are UHF 21-69

Push select button to change from A, B, C and D

### STEPS 1 & 3

Before you program a UHF channel you must make sure that the UHF frequency is not being used in your region. If UHF frequencies are being used in your region, you must have at least two-channel separation from the broadcasted channels. The reason for this is that the signals can spill over to adjacent channels resulting in poor picture quality for adjacent channels.

Example: SBS is broadcast on UHF 33 - you cannot use channel 32, 33, 34, but you can use channel UHF 35.

- **Step 1:** Select the input CH A, B, C or D you wish to set.
- **Step 2:** Use the up and down push buttons to select the UHF channel you require. The channel will be displayed in the channel window next to the up and down push buttons.
- **Step 3:** Push the select button again and repeat the process for other input CHs. Your UHF channel has now been programmed. You will need to do an auto search on your TV to tune into these new channels.

Modulator AV Connections

Connection of an AV device such as a DVD to the modulator requires a set of AV leads.

<b>8072VMPIR</b>	<b>8074VMPIR</b>
Connection of <b>TWO</b> devices with IR capability	Connection of <b>FOUR</b> devices with IR capability

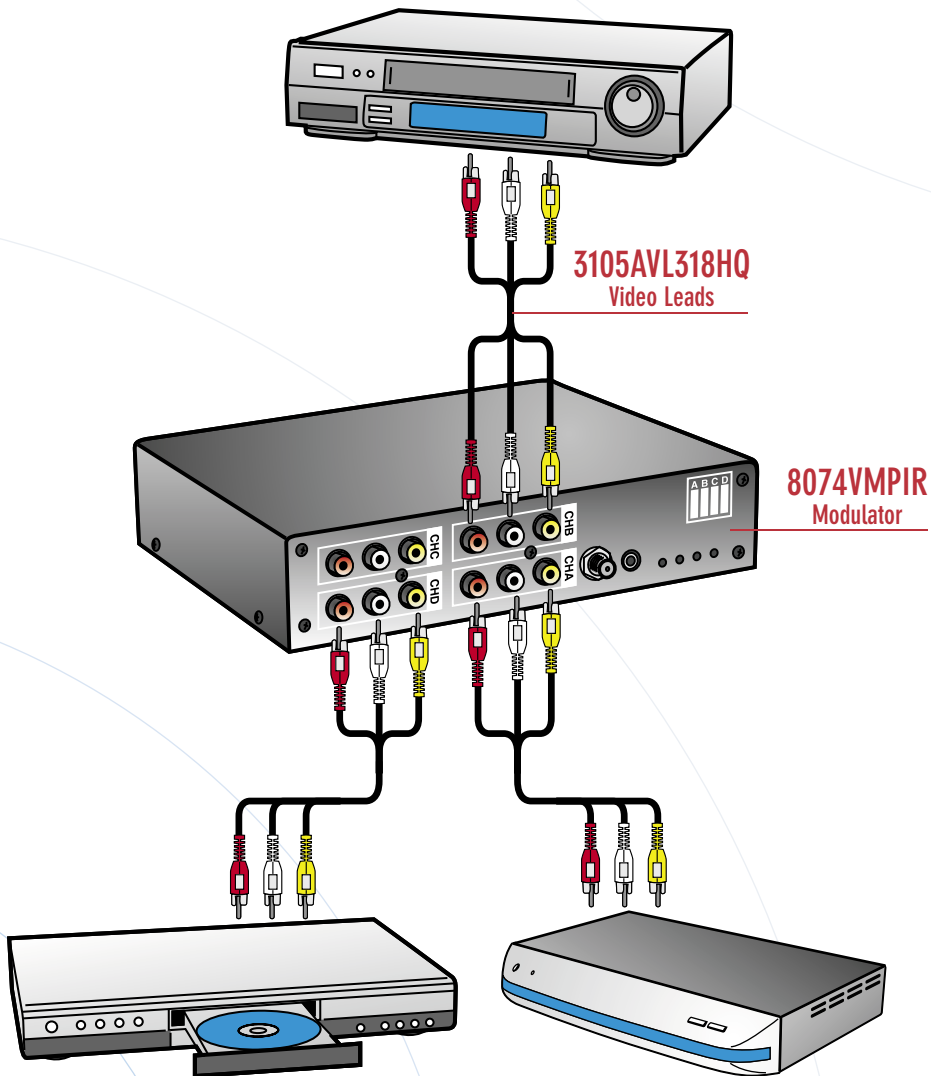

## Modulator AV Connections - Y Lead Connections

Y Leads are used to connect one device (subscription TV decoder) to two different devices (TV & modulator).

If you are using Y Leads to a device to the AV input of your television and to the AV inputs on the modulator, you need to change the position of the Hi-Z dip switches from 75 OHM to Hi-Z for the modulator channel you are splitting. This will allow the loop through with minimal losses.

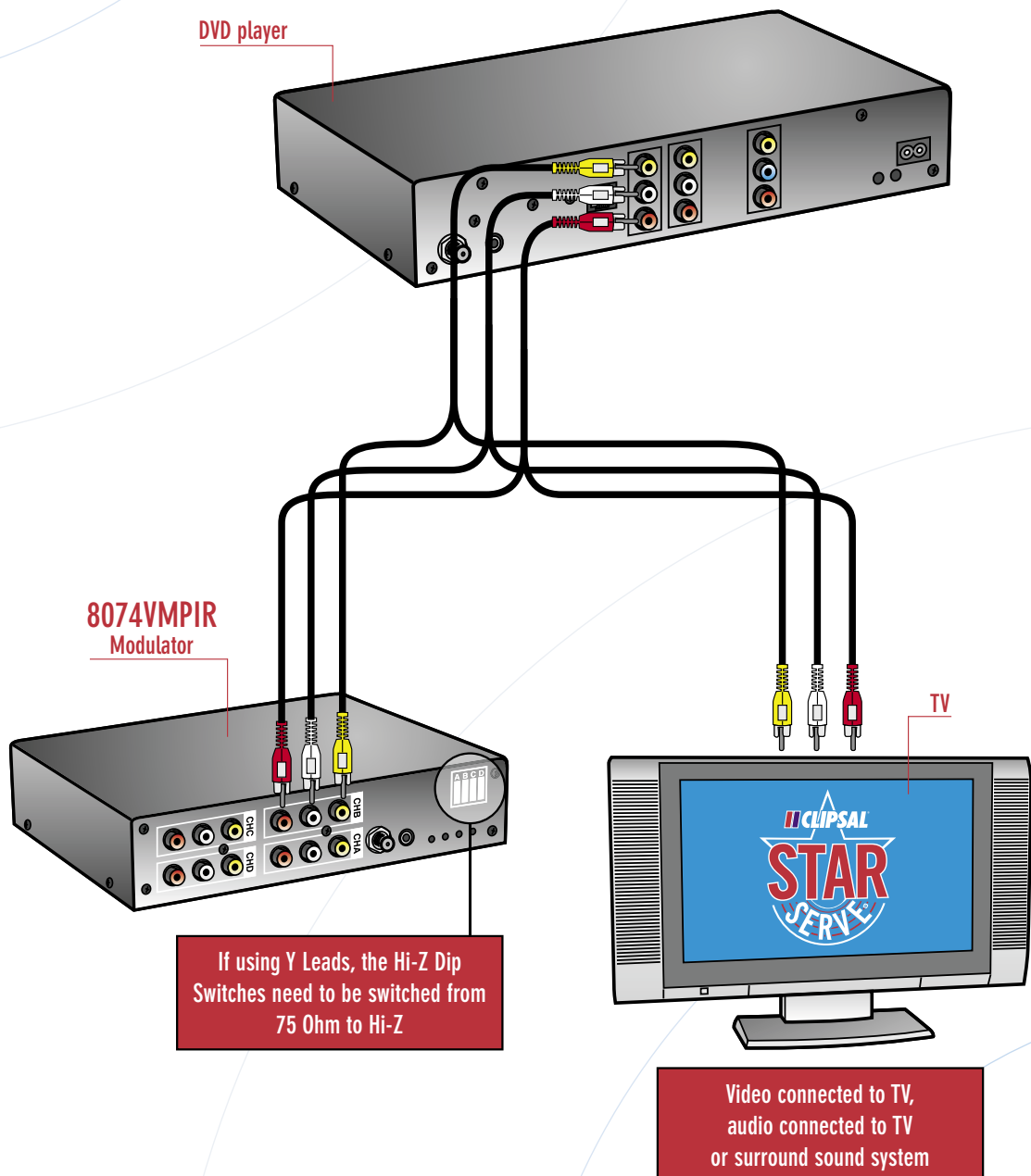



## IR Emitter Leads

The IR emitter leads (or repeaters) are plugged into the modulator. The head of the IR emitter lead is to be fixed over the IR receiver of the device that is to be remotely controlled with the sticky backing provided on the emitter head.

The emitter head will allow the pass through of IR signals from the remote control so the device can operate normally from the room that it is in.

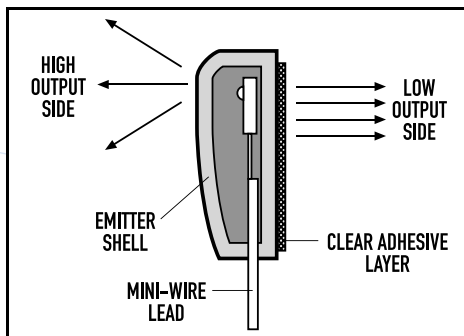
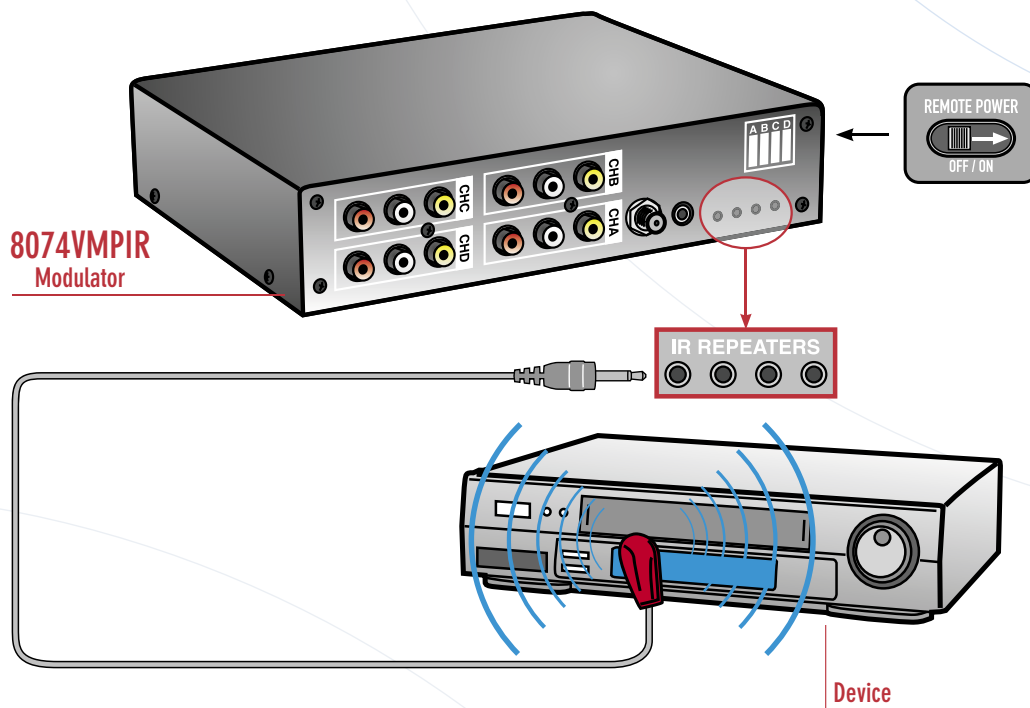

To locate the IR pickup of the device you wish to control, place your thumb over the suspected location of the IR pickup. Use the remote control to change channels, fast forward or skip.

When you cannot change the status of the device, you are directly over the IR pickup.

Note the location and stick the IR emitter lead into position.



The IR system will only work when the remote power switch is in the ON position.

## IR Target

Connection of the IR target is a simple process.

You will require a **F-Type to F-Type fly lead** to connect the **wall outlet to the IR target**. (The back of the IR target is marked "From System"). You can use the existing **F-Type to PAL fly lead** from the **IR target to the TV**. (The back of the IR Target is marked "TO TV"). The IR Target can then be placed onto the TV and stuck down with double sided tape or velcro.

Clipsal recommends you only use a **30PFM Socket** at the wall outlet. This socket is digital ready and does not have AC isolation or a capacitor that will block the IR signal. Failure to use the 30PFM may result in no IR control of devices.

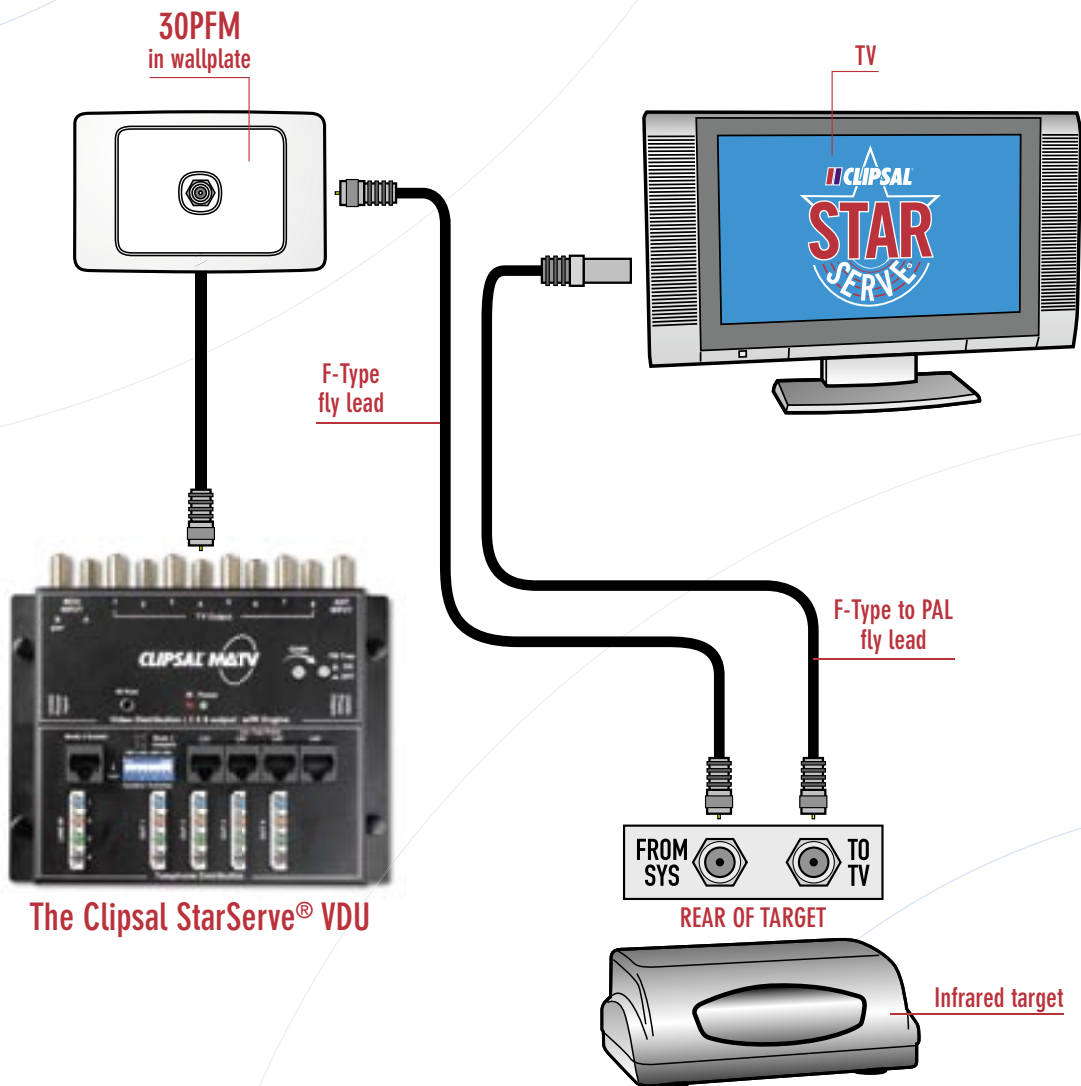

If installing IR targets with plasma screen TVs, you must locate the IR target **BELOW** the screen. Plasma screens emit radiation that can drown out IR frequencies. You may need to adjust the location of the IR target on-site, depending on the plasma screen.

IR Control of Devices

To remotely control devices from other rooms of your home you will need to use the products that have IR capability.

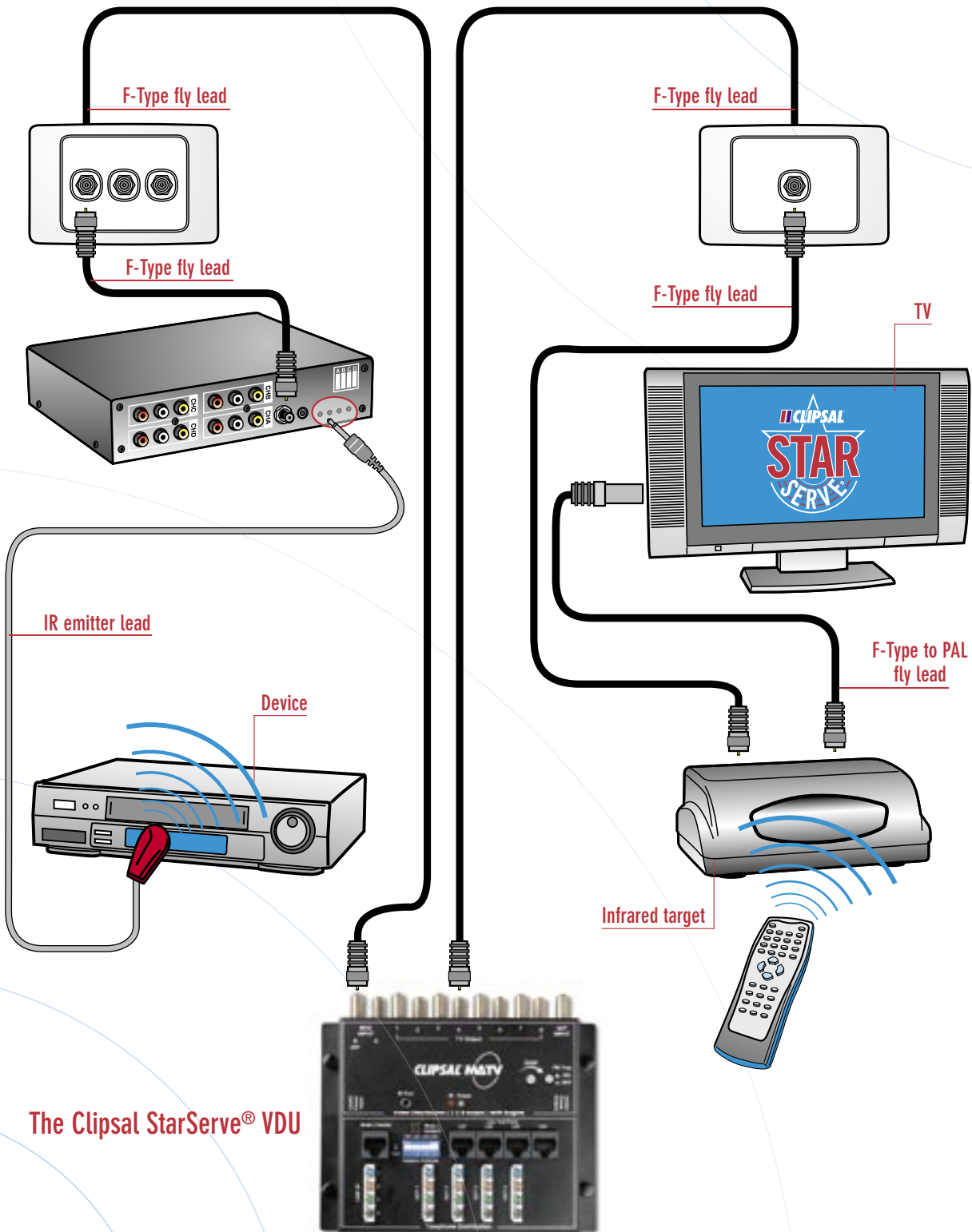

The Clipsal StarServe® VDU



## Modulator Input A - Single Surveillance Camera

“MOD INPUT A” is used for devices not requiring IR remote control such as surveillance cameras. A modulator is connected to “MOD INPUT A” via a RG6 Quad Shield Coax Cable. Refer to the modulator diagram below for connection details.

The camera is connected to the modulator via the RCA connections. This enables the camera to be viewed from any TV connected to a Clipsal StarServe® VDU output.

Things to consider:

- **Location of modulator** – where are you going to put it?
- **How are you going to power the camera** – locally or remotely?
- **How many cameras are you going to have** – how many channels do you require?

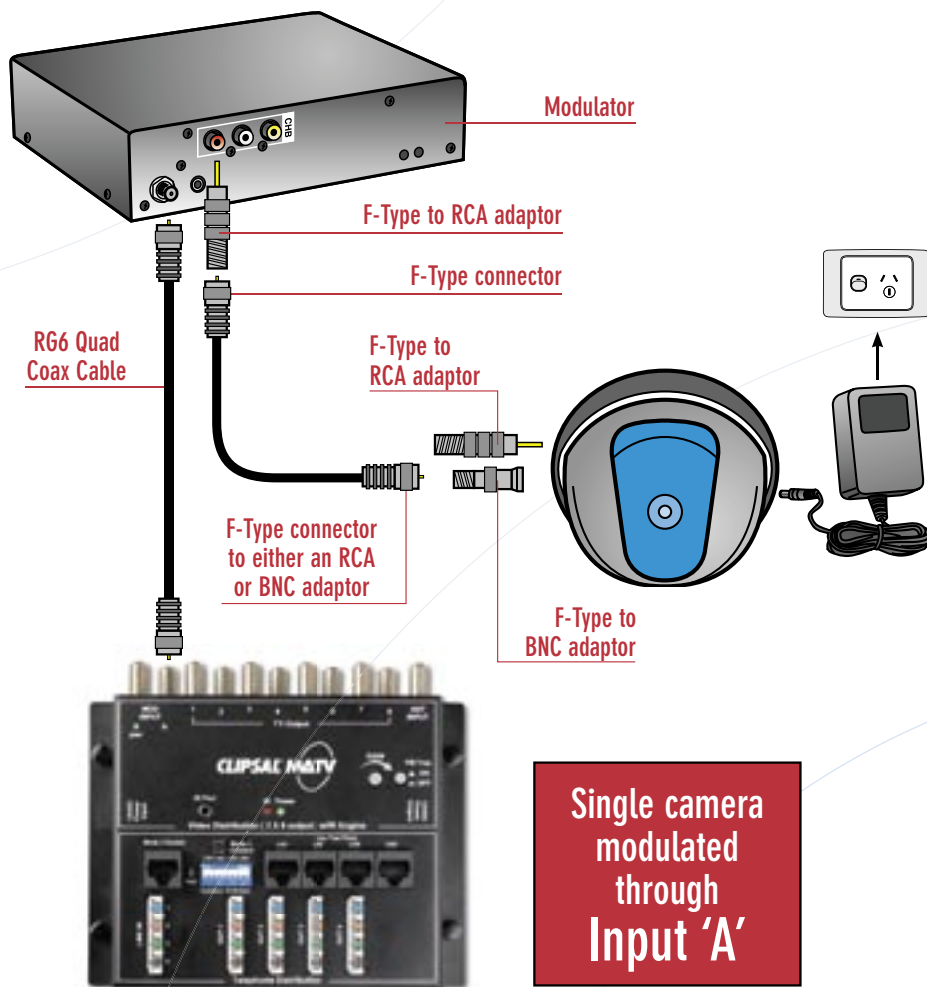

A one-piece connector provides the best quality connection of devices.  
An adaptor is suitable for the majority of installations.

Modulator Input A - Multiple Surveillance Cameras

Where multiple cameras are needed, a two or four channel modulator is required.

8072VMPIR – Two Channel Modulator

8074VMPIR – Four Channel Modulator (Pictured)

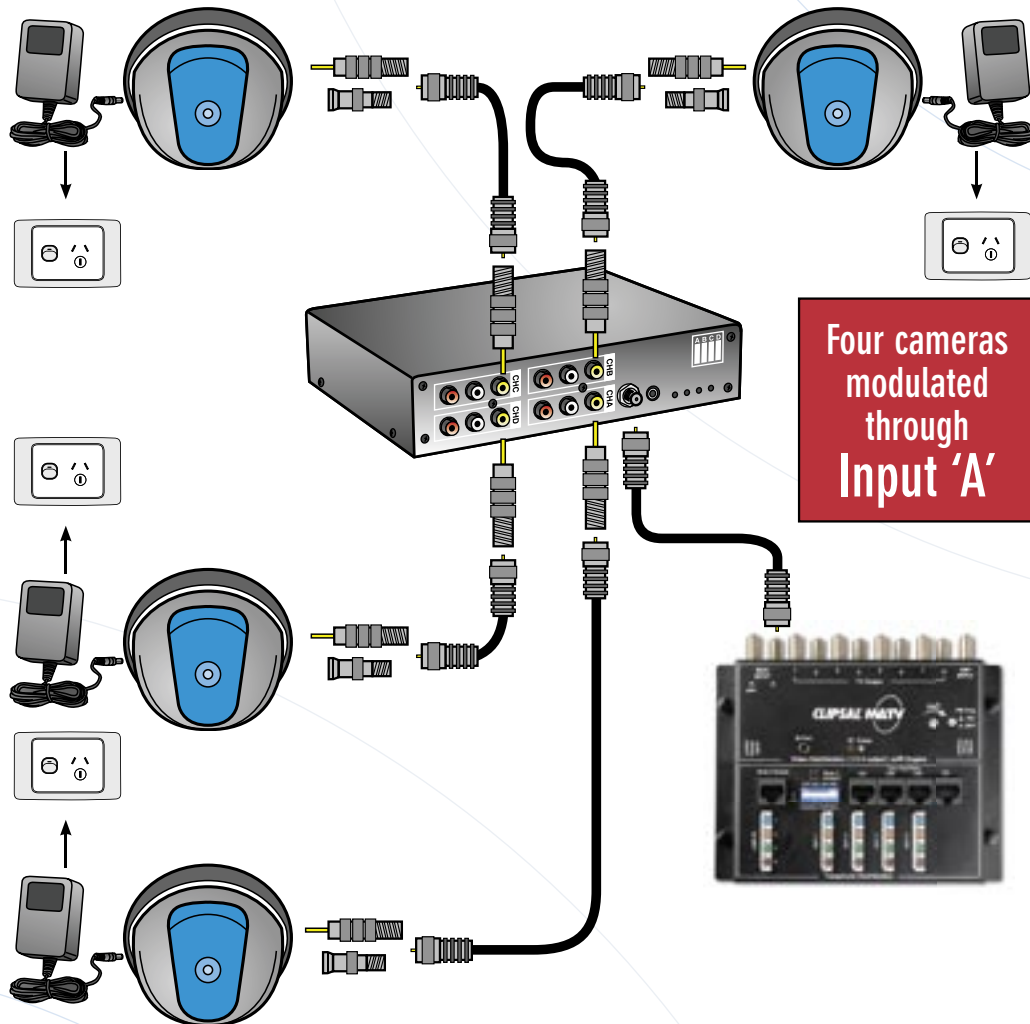

	<p><b>3105FF-RCA</b> F-Type Female to RCA Male Adaptor</p>
	<p><b>3105FF-BNC</b> F-Type Female to BNC Male Adaptor</p>



## Surveillance Camera Connection Using an Audio/Visual Balun

The **8000AVB Audio/Visual Balun** allows the connection of cameras (and other audio/video devices) to remote TV locations throughout the home using structured cabling (Category 5e or 6).

This will ensure the cost effective transmission of crystal clear images over distances of up to 100 metres.

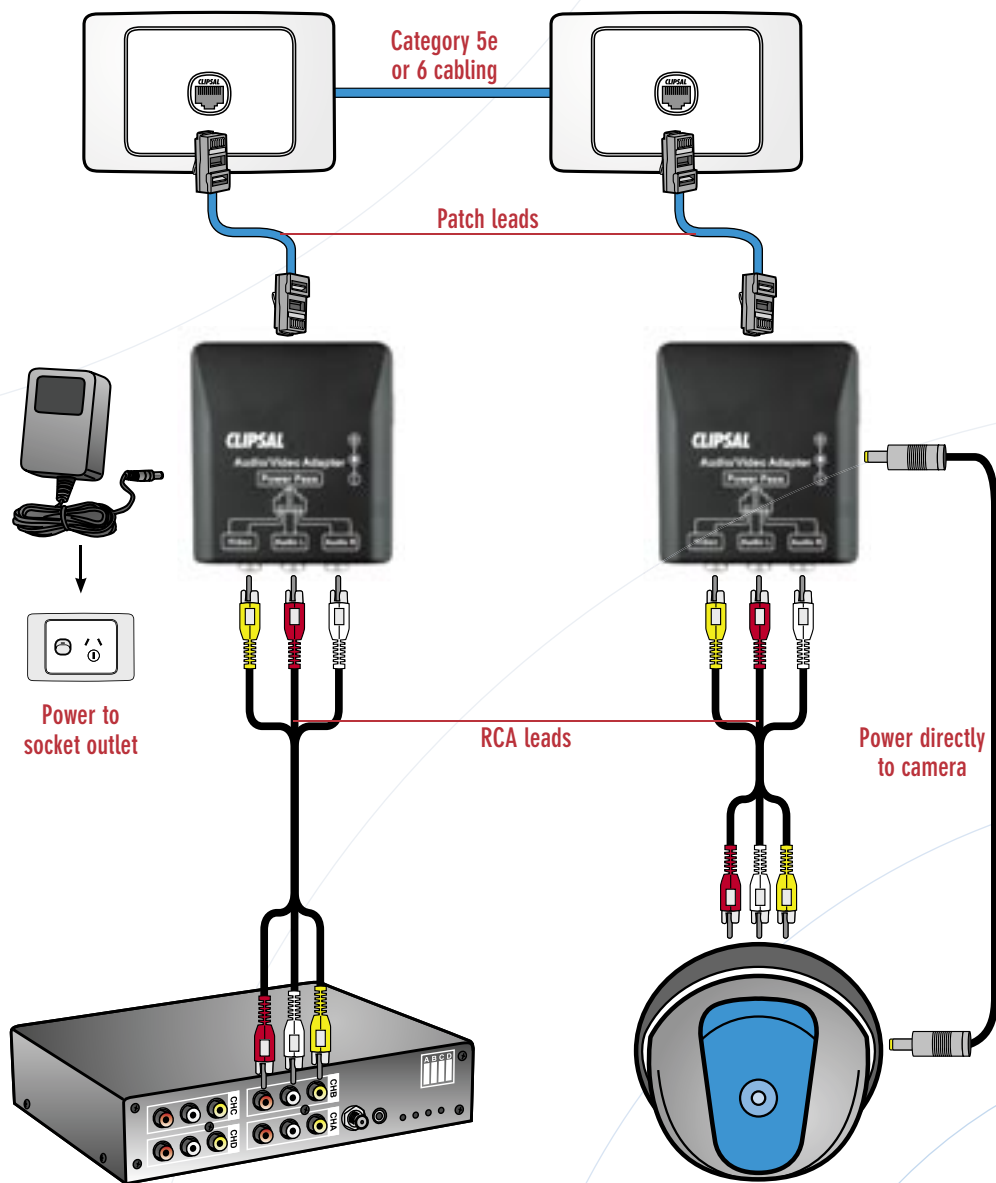



## Connecting More Than Eight Outputs

The Clipsal **8000IREX** is used to expand the IR system of the Clipsal **3105VDU38IRT** and the **8073/8VHPIR** Video Distribution Units (VDU). It provides up to 64 outputs with IR control (eight VDUs using the outputs from the master VDU).

The 8000IREX passes IR signals from the expansion VDUs to the master VDU. All broadband and modulated signals brought to the master VDU are available at the expansion VDU outputs with no signal loss.

- Each expansion VDU must be powered by its own separate power supply
- Modulators connected to the expansion VDUs will only be viewable on outputs from that expansion VDU.

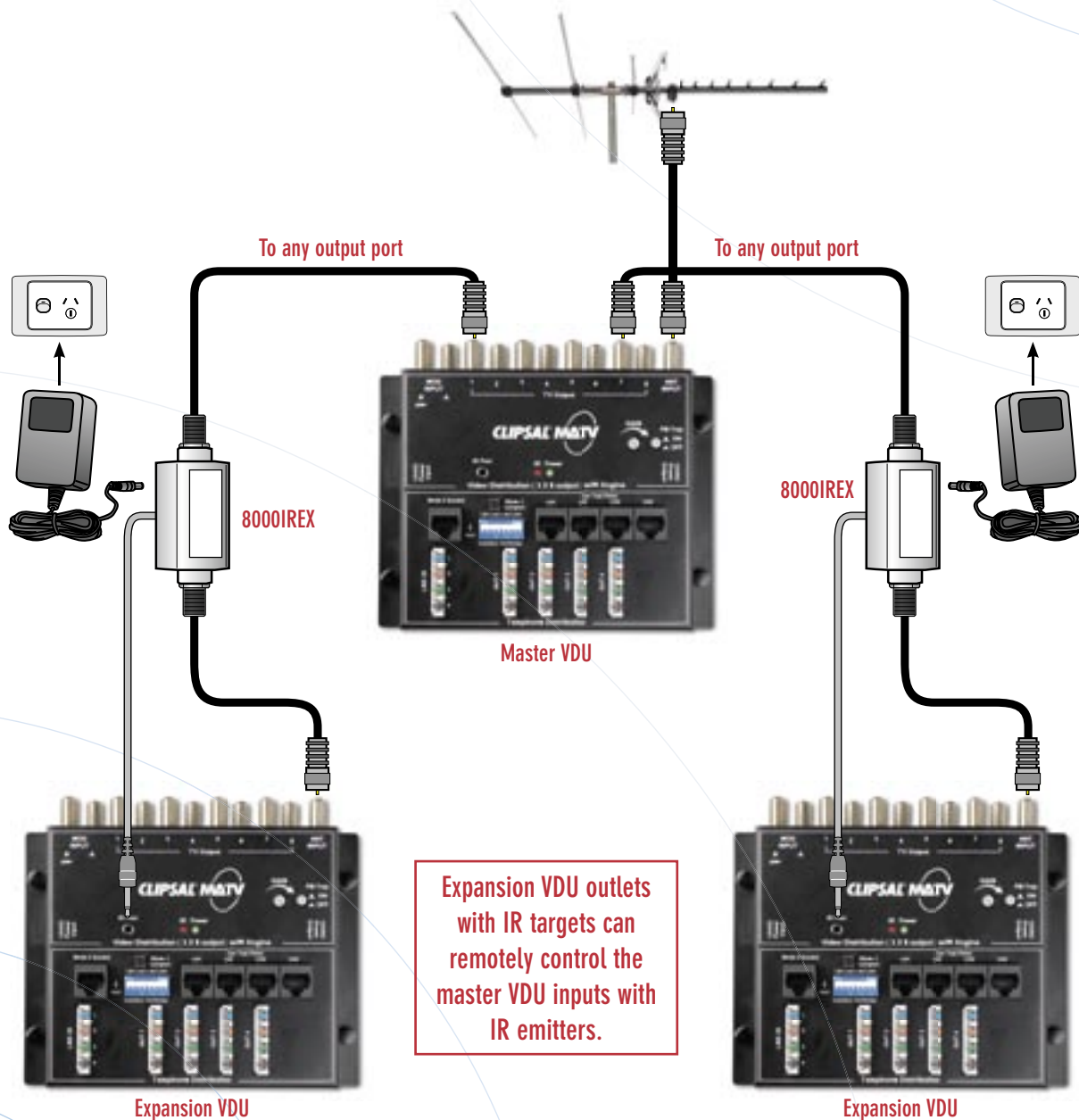

## Telephone/Data Cabling

Clipsal StarServe® uses Category 5e or Category 6 cabling for all telephone, internet, data networking and video distribution. The part numbers required for the Clipsal solution are as follows:



**2D4P5IPV3B,BU**  
Category 5e UTP cable



**2D4P6IPV3B,BU**  
Category 6 UTP cable

## Telephone/Data Outlets and Patch Panels

All Clipsal telephone, internet and data networking outlets are to be Clipsal Titanium® outlets. Clipsal Titanium® outlets are available in Category 5e or Category 6 shuttered or unshuttered versions.

In domestic homes Clipsal recommend shuttered outlets, as these will protect the outlet and pins from dust found behind TV cabinets and under carpets.



**30RJ88SMA5SH**  
Cat 5 Shuttered Jack

**30RJ88SMA6SH**  
Cat 6 Shuttered Jack

**30RJ88SMA5**  
Cat 5 Unshuttered Jack

**30RJ88SMA6**  
Cat 6 Unshuttered Jack



## Patch Leads

Clipsal patch leads are available in Category 5e and Category 6 and come in several different colours and lengths. Clipsal produce specially made 0.2 metre patch leads for Clipsal StarServe®.



## Required Data Tools

The termination of the data cabling must be done with a Clipsal / Krone type tool. A cable stripper must be used to strip the sheath of the category cable to avoid the cutting of the conductors, which will affect the performance of the installation.



**3100RJA5V**  
Punchdown Tool

Recommended Cabling for Telephone and Data Requirements

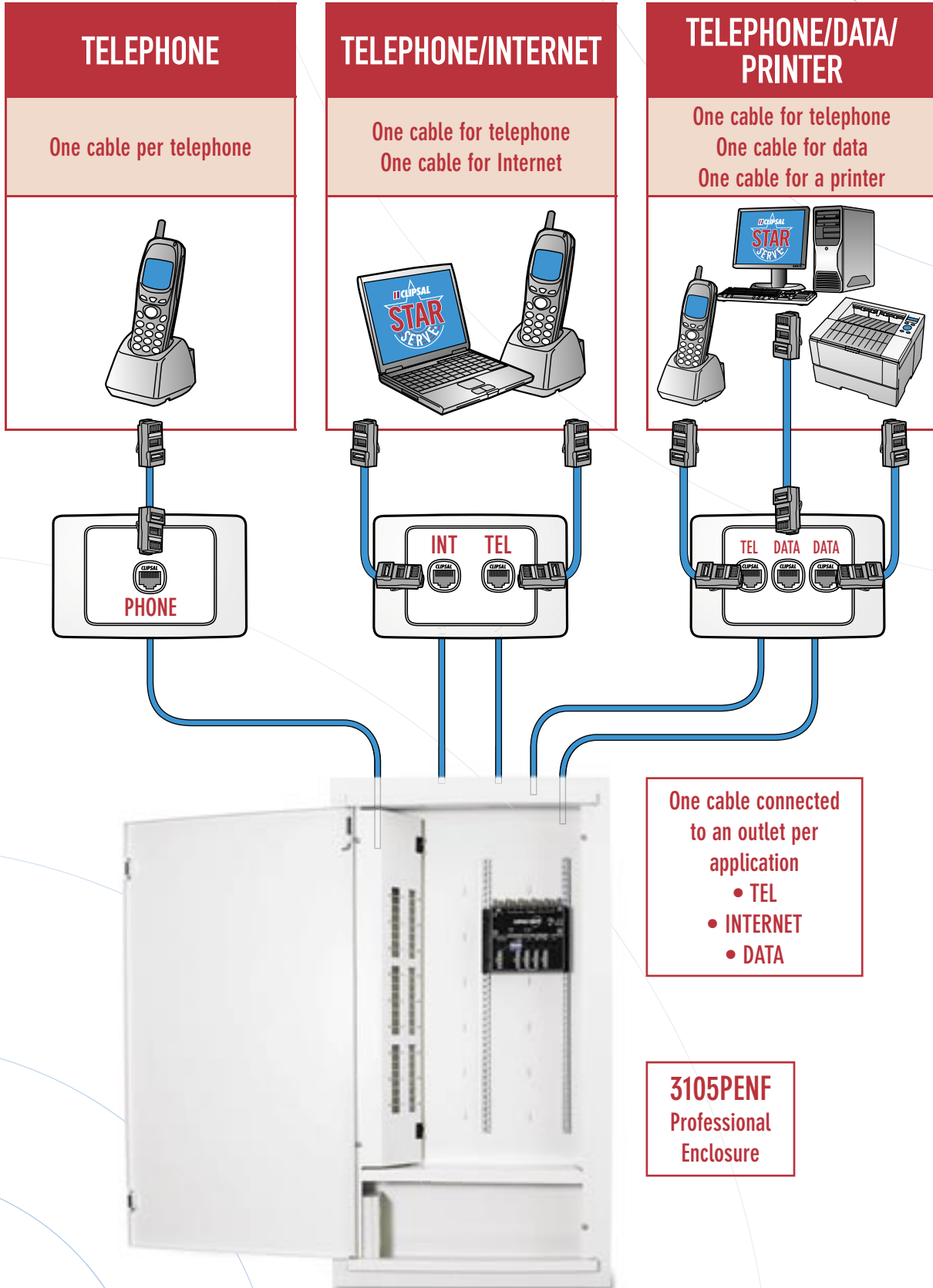

## Telephone Connection

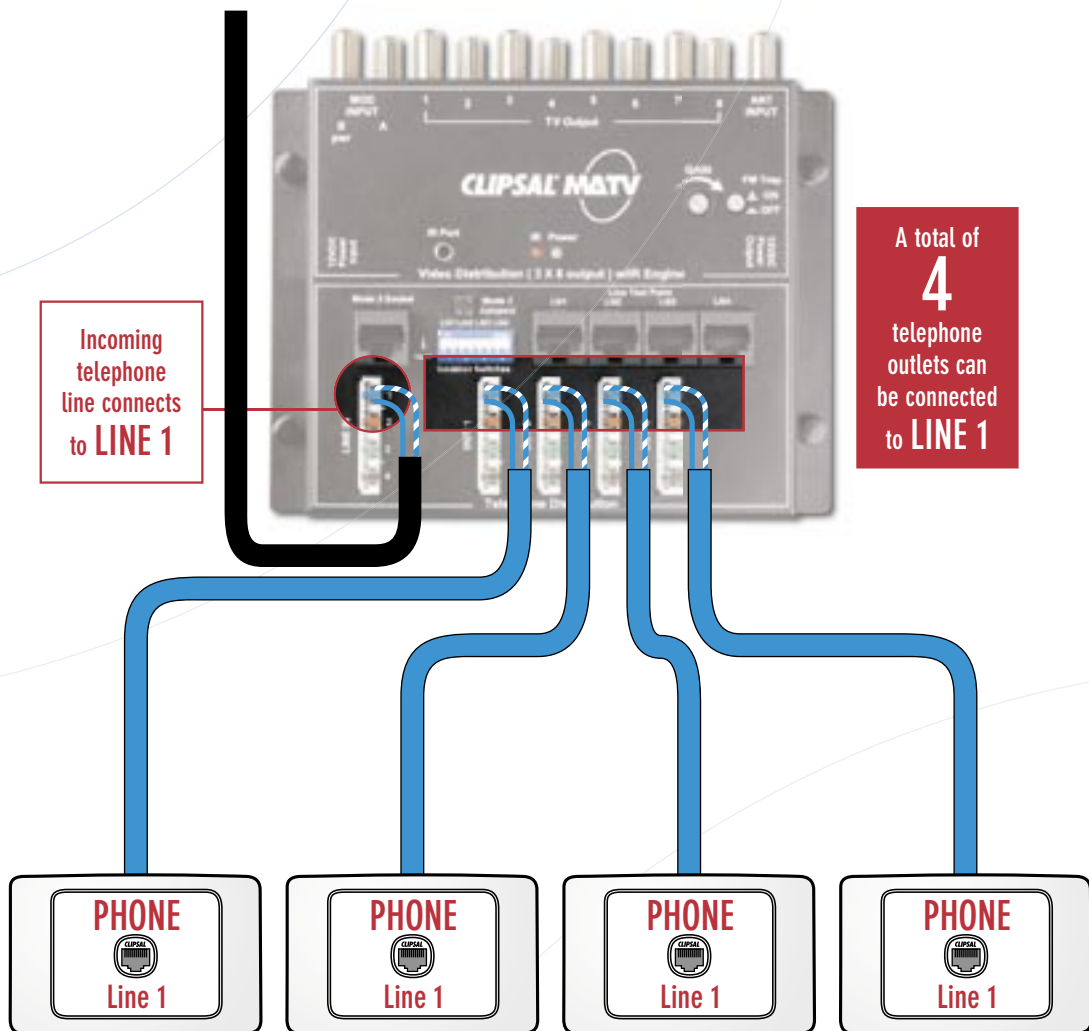

Connect the incoming telephone line to LINE 1 of the telephone patchdown card.

The line is now internally connected to all the blue pair connectors.

Use the Line Test Point RJ sockets to test the telephone line by pressing the Line Test Point switch to 'TEST'.

Make sure you reset the test switch to enable the telephone line to be connected to the outlet.



You must have the appropriate licenses for telephone cabling installation to connect telephone cabling to Clipsal StarServe®

Jumpering Telephone Outlets

A total of **8** telephone outlets can be connected to **LINE 1**

Incoming telephone line connects to **LINE 1**

Use excess wire as jumper wire from **LINE 1** to **LINE 2**: this doubles the number of telephone outlets available

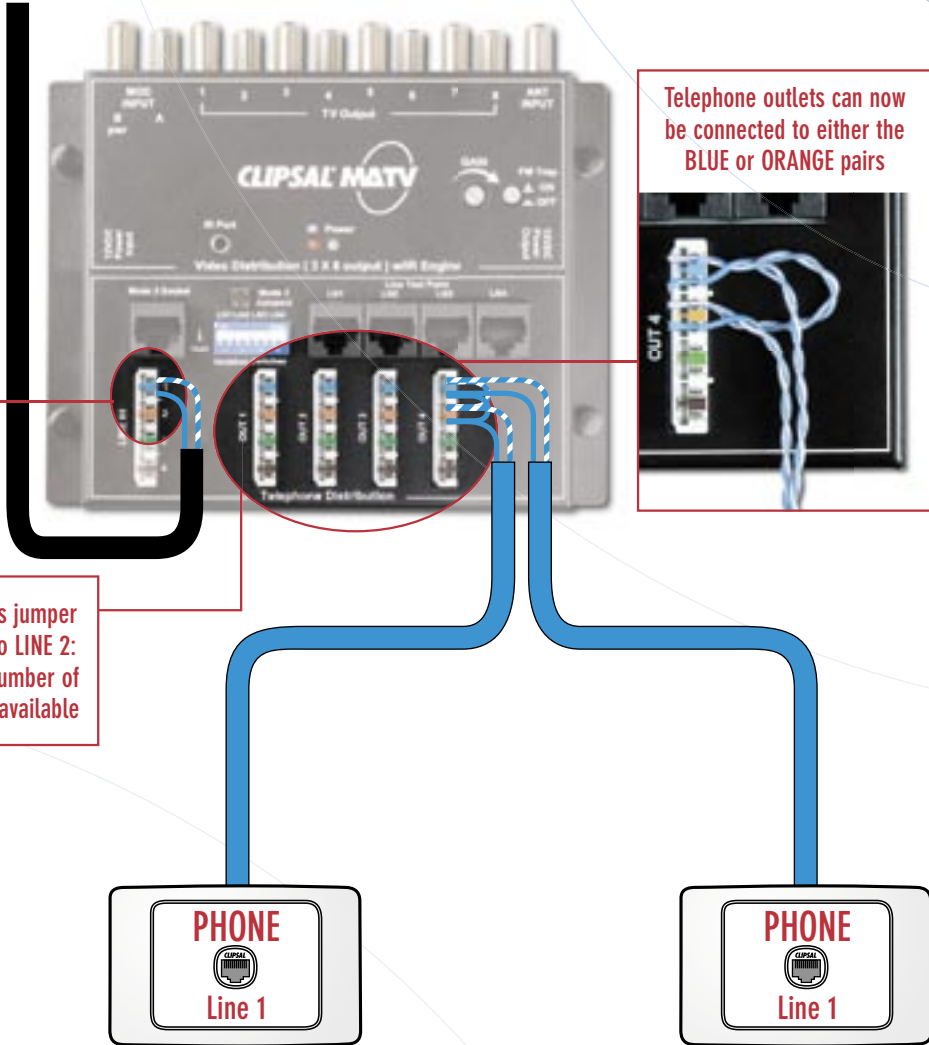

Telephone outlets can now be connected to either the **BLUE** or **ORANGE** pairs

When jumpering **LINE 1** to extend the number of telephone outlets, you must do it on the outlet side so as to not compromise the Mode 3 functionality.  
 The number of telephones that can be connected to any telephone line is determined by the **REN** of the phone (Ring Extension Number).



Mode 3 Connection



SECURITY SYSTEM

Two pair telephone cable fly lead to alarm dialler

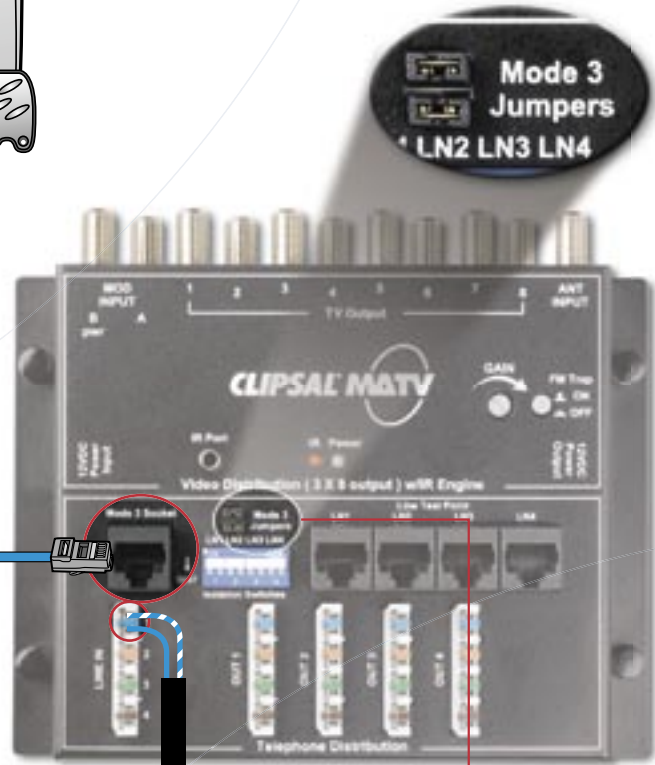

Mode 3 Jumpers LN2 LN3 LN4

Incoming telephone line connects to **LINE 1**

When connecting to the alarm panel, the **MODE 3 JUMPERS** need to be **REMOVED** to make the telephone connection.

**NOTE:** the **MODE 3 JUMPERS** must be kept inside the enclosure in case the Alarm System Dialler needs to be removed.

The alarm panel connects through a Mode 3 socket.  
 When the alarm panel is triggered into alarm mode, it automatically cuts off all the other telephone extensions and dials out to the monitoring service.  
 The Mode 3 socket is the first connection.





ADSL Connection

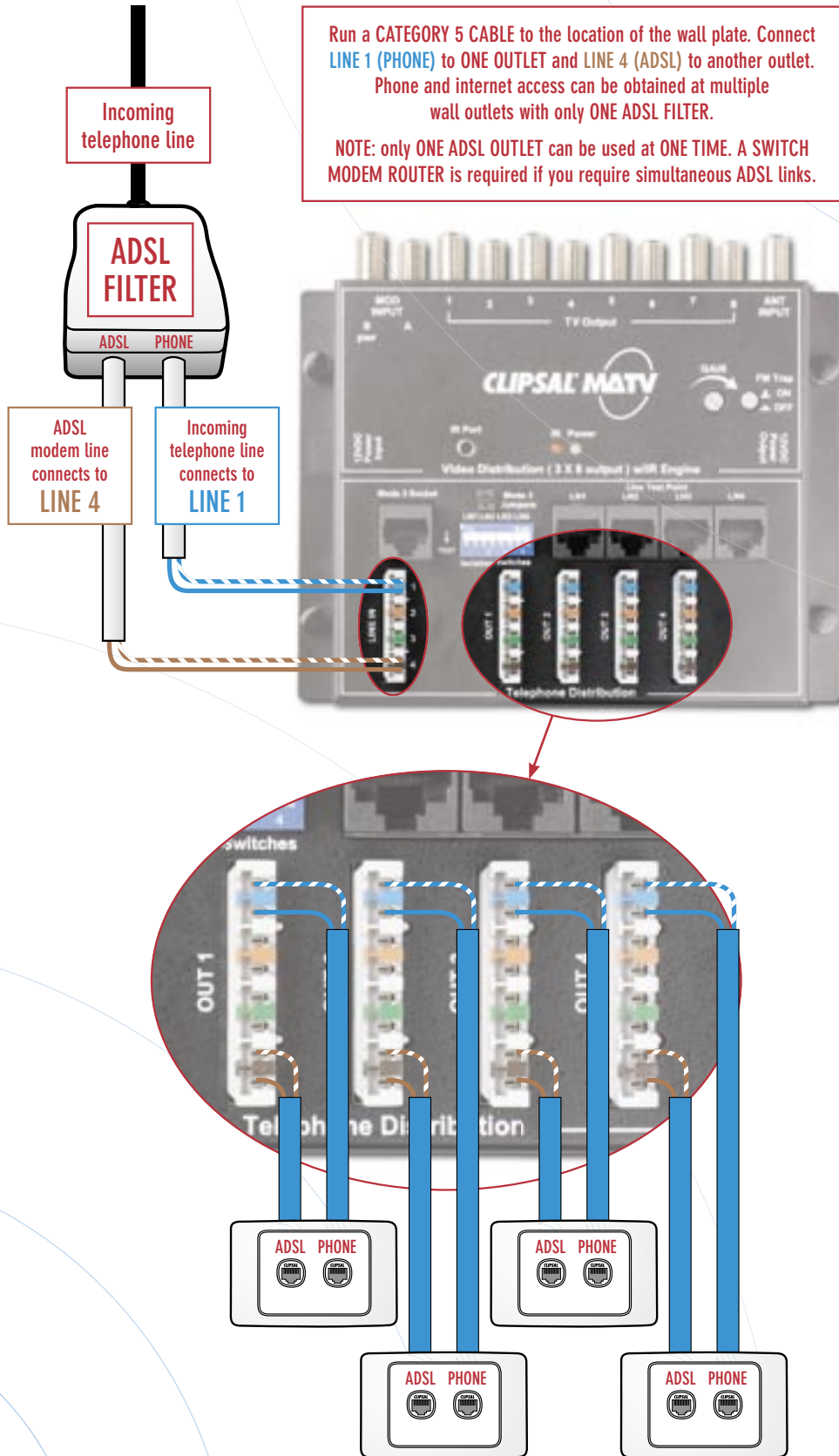

INSTALLATION GUIDE





ADSL Connection with Jumpering Leads

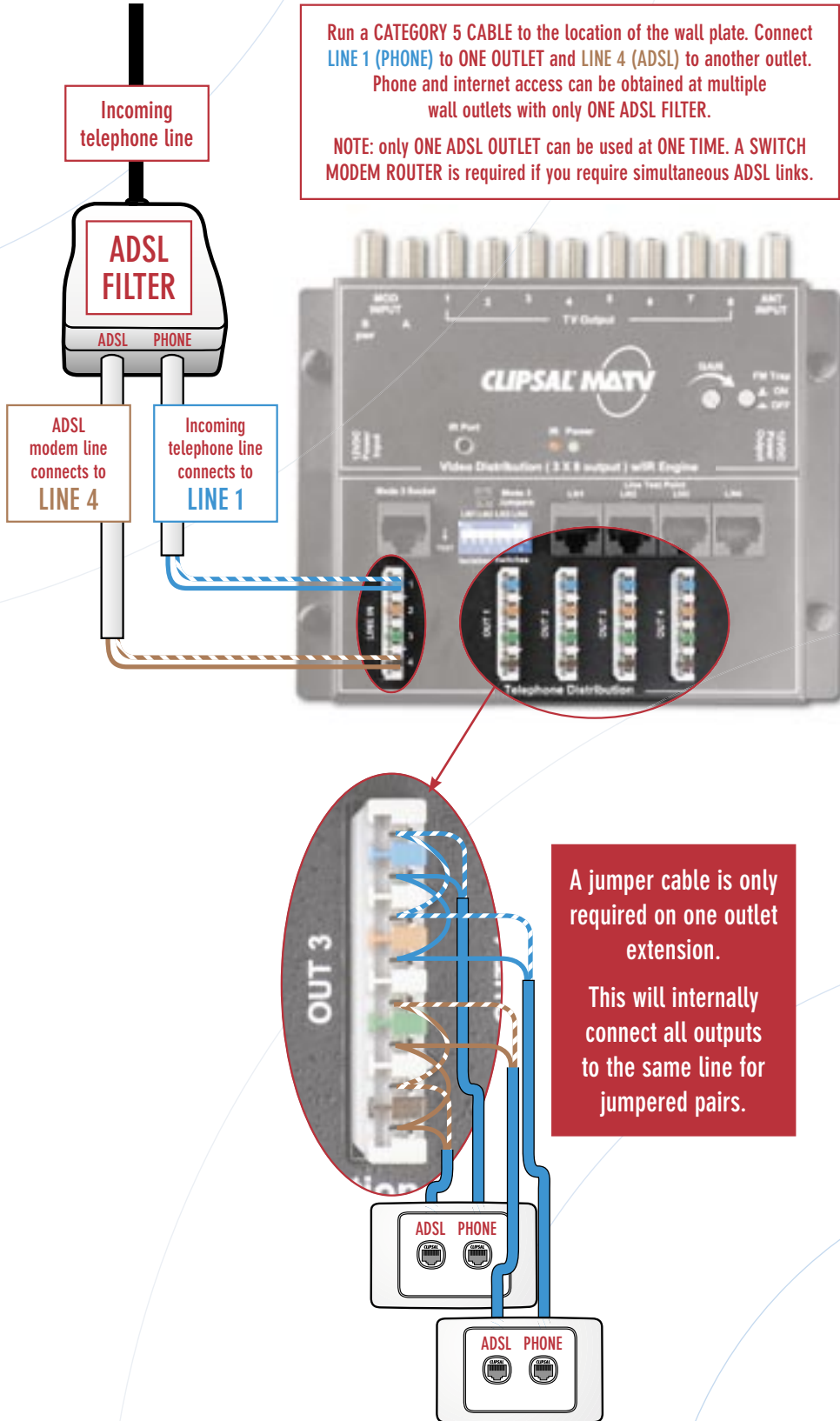

INSTALLATION GUIDE



ADSL Switch Modem Router Connection

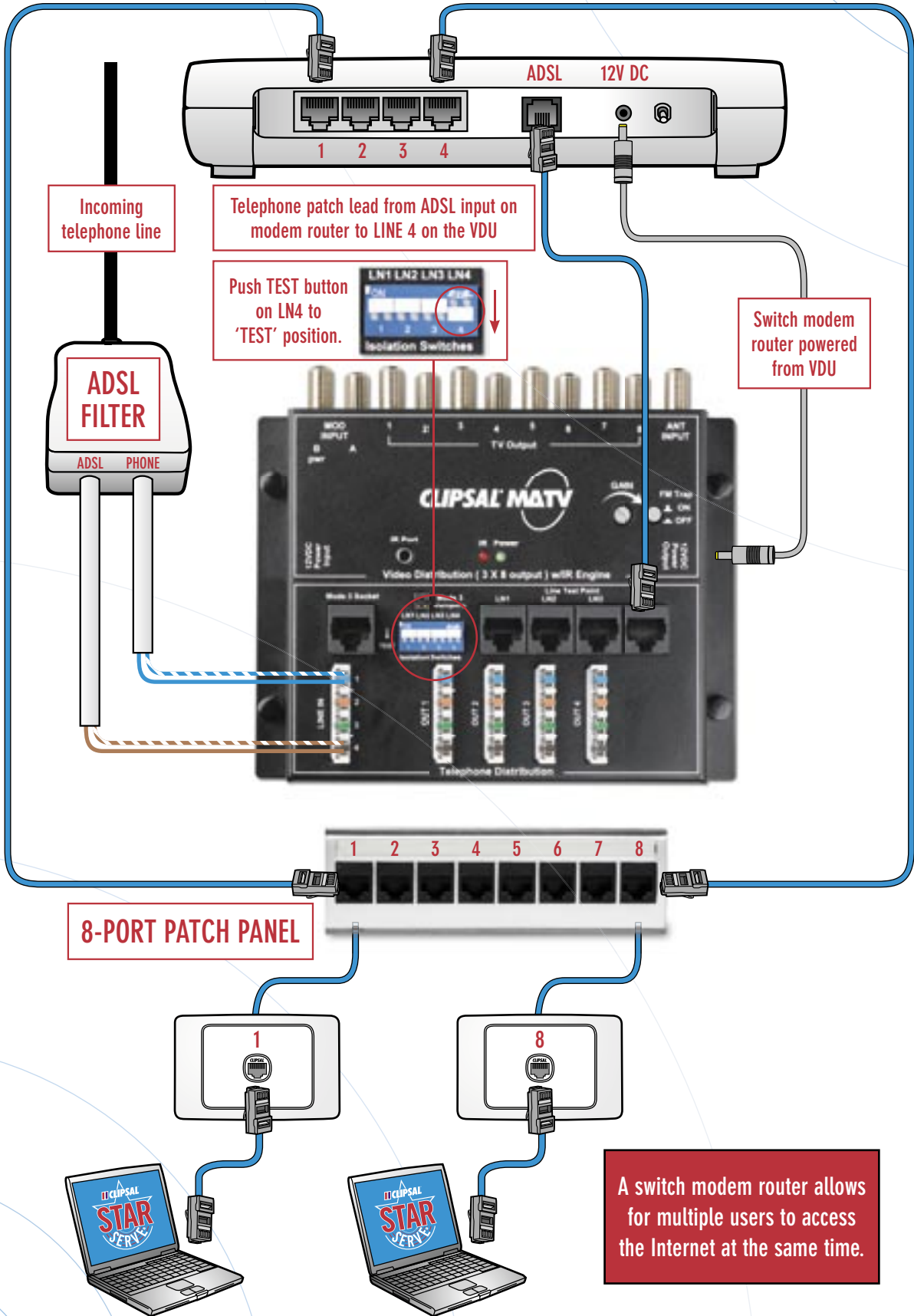

STAR  
 SERVE  
 ON  
 GUIDE



### Patch Panel Setup - Data Cabling

Data cabling is simply a cable connecting two data outlets together to make a 'data extension cord'. One outlet is installed into a wall plate and the other is located in a panel alongside a number of other outlets.

The connection of the data outlets are the same at both ends.

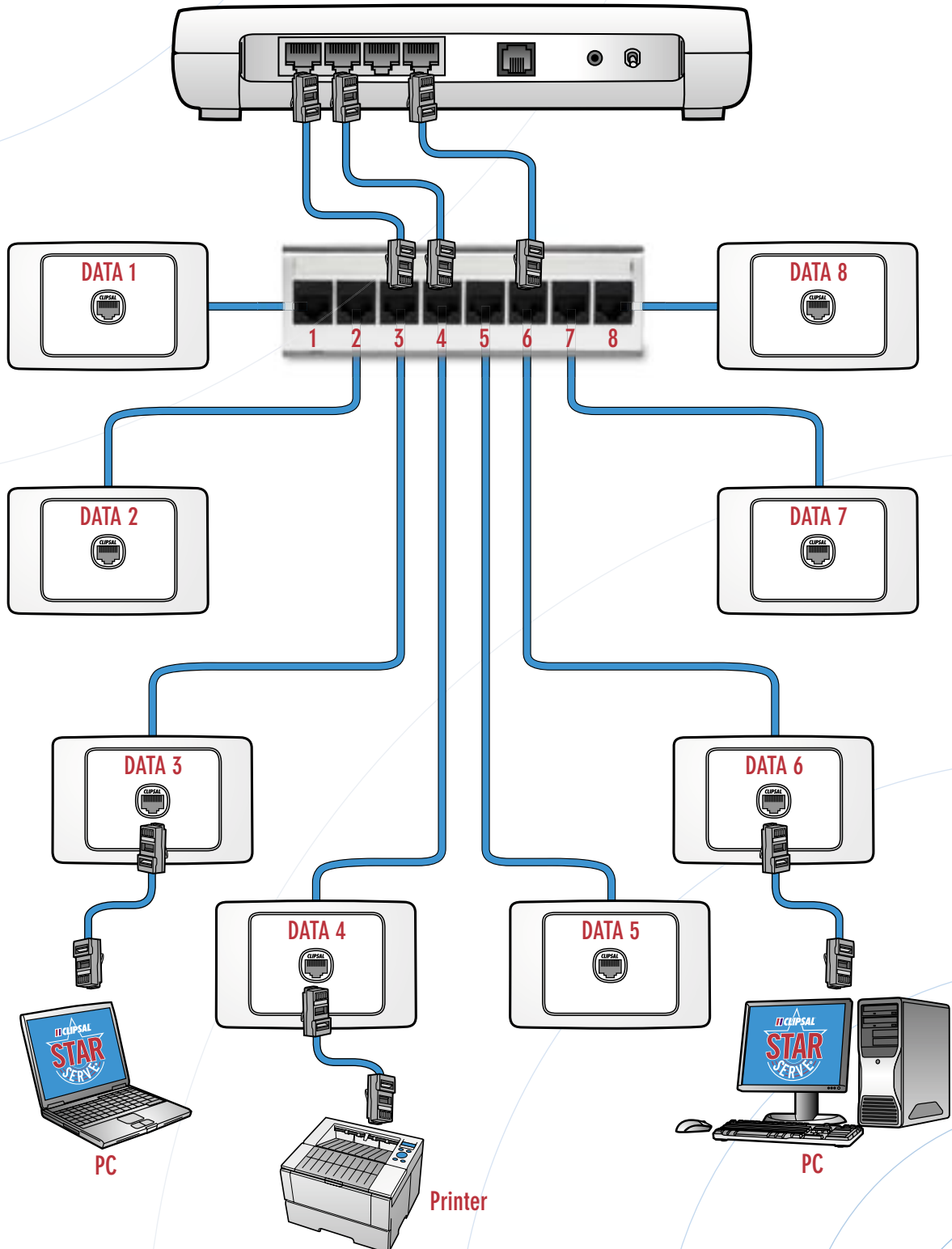

Patch Panel Connection for Structured Cabling System

The telephone patch panel is a simple connection that performs the same function as the telephone card on the combination VDU.

You terminate one telephone line to obtain four outlets for that line. The connections are made internally as part of the circuit board. There are two termination points for two incoming telephone lines and four extensions for each incoming line.

To patch a telephone line to an outlet, you will need to use a patch lead. Plug the patch lead into the telephone line you require (Line 1 or 2). Then plug the other end of the lead into the data patch panel outlet that is connected to the outlet you want to convert into a telephone line.

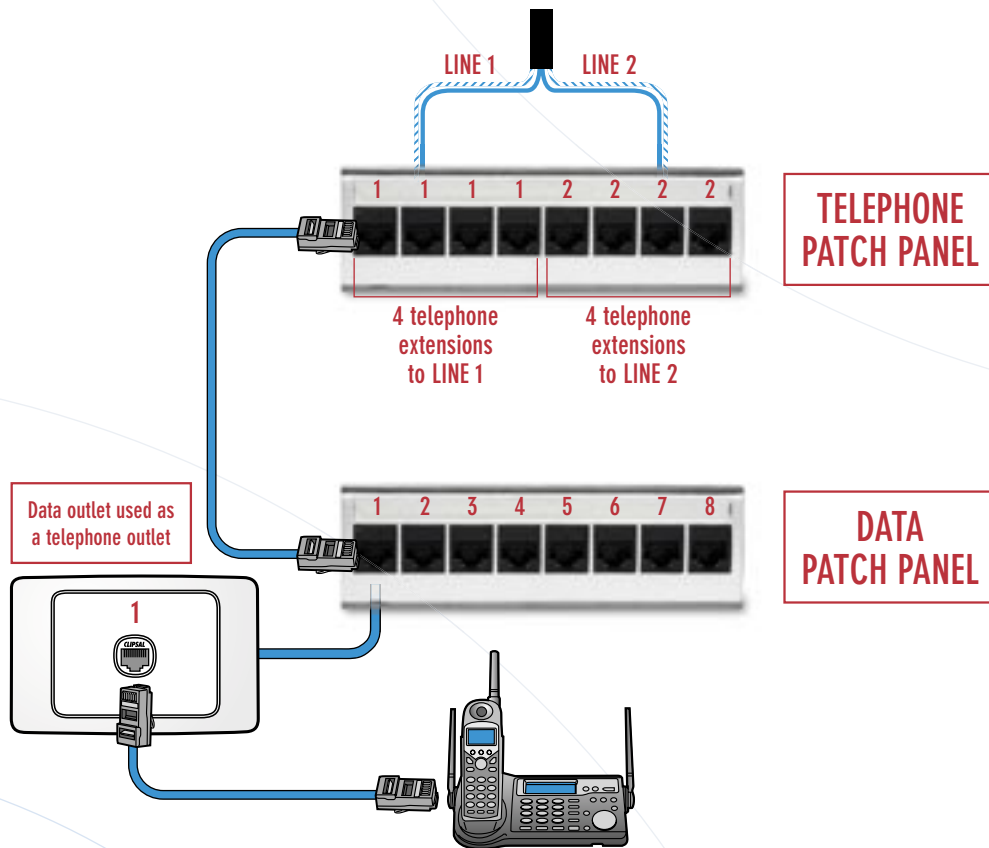

PATCH PANEL/ENCLOSURE COMPATIBILITY CHART

		3105ABEN	8000LEN	8000MEN	8000PEN*
Data Angled Patch Panels	3105APP8/5E	✓	✓	✓	✓
	3105APP8/6	✓	✓	✓	✓
Telephone Patch Panels	8052/4RJ	✗	✗	✗	✓
	8052/4RJSM	✗	✓	✓	✗
	8052/4RJDM	✗	✗	✓	✗
Data Patch Panels	8058/8RJ	✗	✗	✗	✓
	8058/8RJSM	✗	✓	✓	✗
	8058/8RJDM	✗	✗	✓	✗

\*The 8000PEN is to be phased out during 2006 and replaced by the 3105PENF and 3105PENS.



## Telephone Distribution using a Telephone Patch Panel

By using a telephone patch panel you can distribute two incoming telephone lines to four locations for each incoming line. You can also move your telephone outlets as often as you require by patching across to a different outlet.

For your customers who want to be able to patch across their telephone lines this is an excellent way to do it.

The telephone patch panel is internally connected to a single punch down block on the back of the panel. One termination can connect four extensions for that line. You must have an additional data patch panel for this to work.

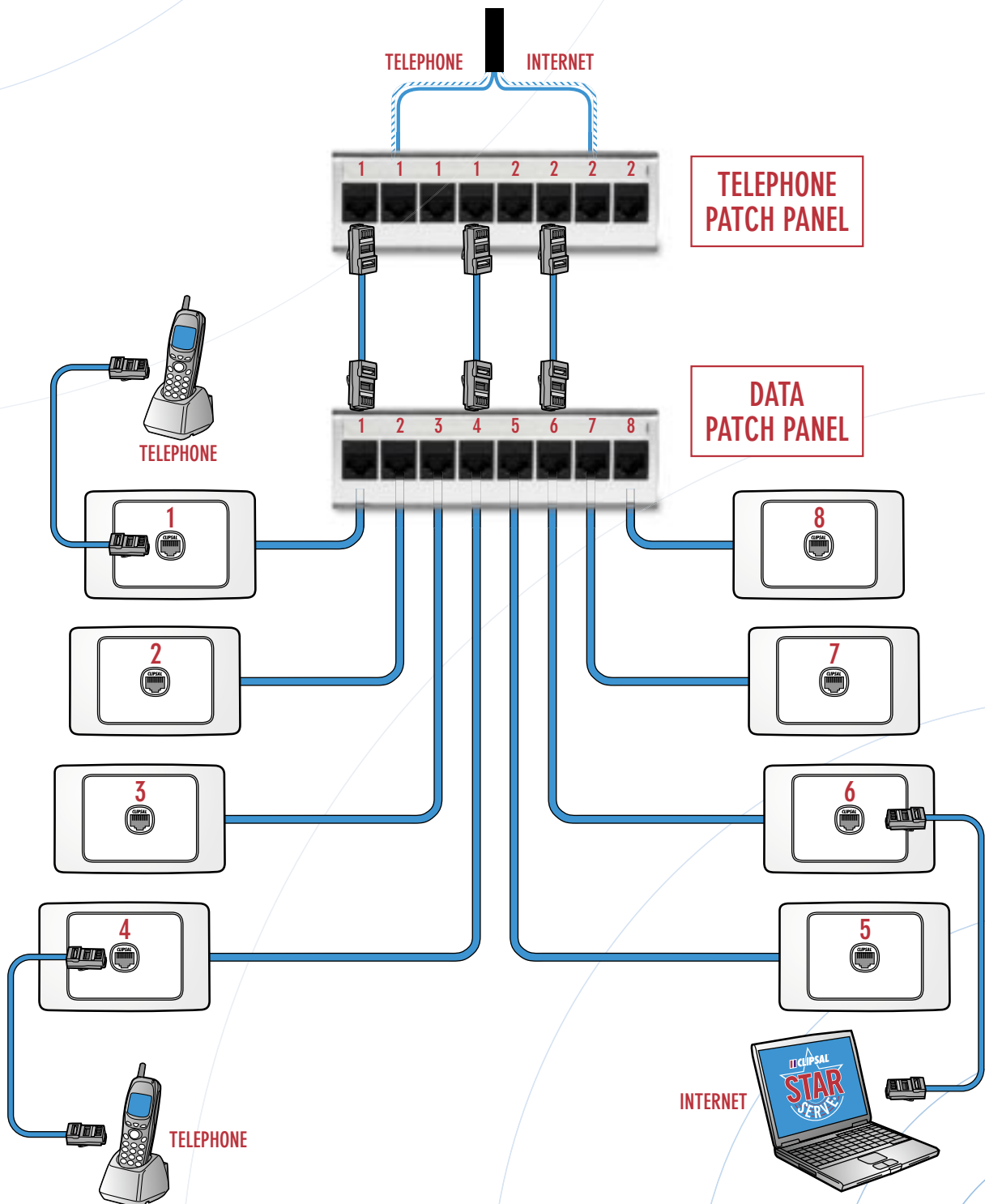

## Foxtel IQ Cabling Requirements - Domestic

### FOXTEL IQ COAX CABLING DOES NOT CONNECT TO CLIPSAL STARSERVE®

Foxtel require two Foxtel approved RG6 Quad Shield Coax Cables run from the satellite dish mounted on the roof to the location of the Foxtel decoder (**2B6Q3B**).

The cables must be connected with Foxtel approved F-Type Compression Connectors (**3105RG6FC50**). The cables must connect to Foxtel approved TV mechanisms (**30PFM**). A telephone outlet is required for the inbuilt modem of the Foxtel IQ decoder for communication back to Foxtel for pay per view functions and billing.

Run a Category or telephone cable from the Clipsal StarServe® to the Foxtel wall plate and terminate to the main telephone line.

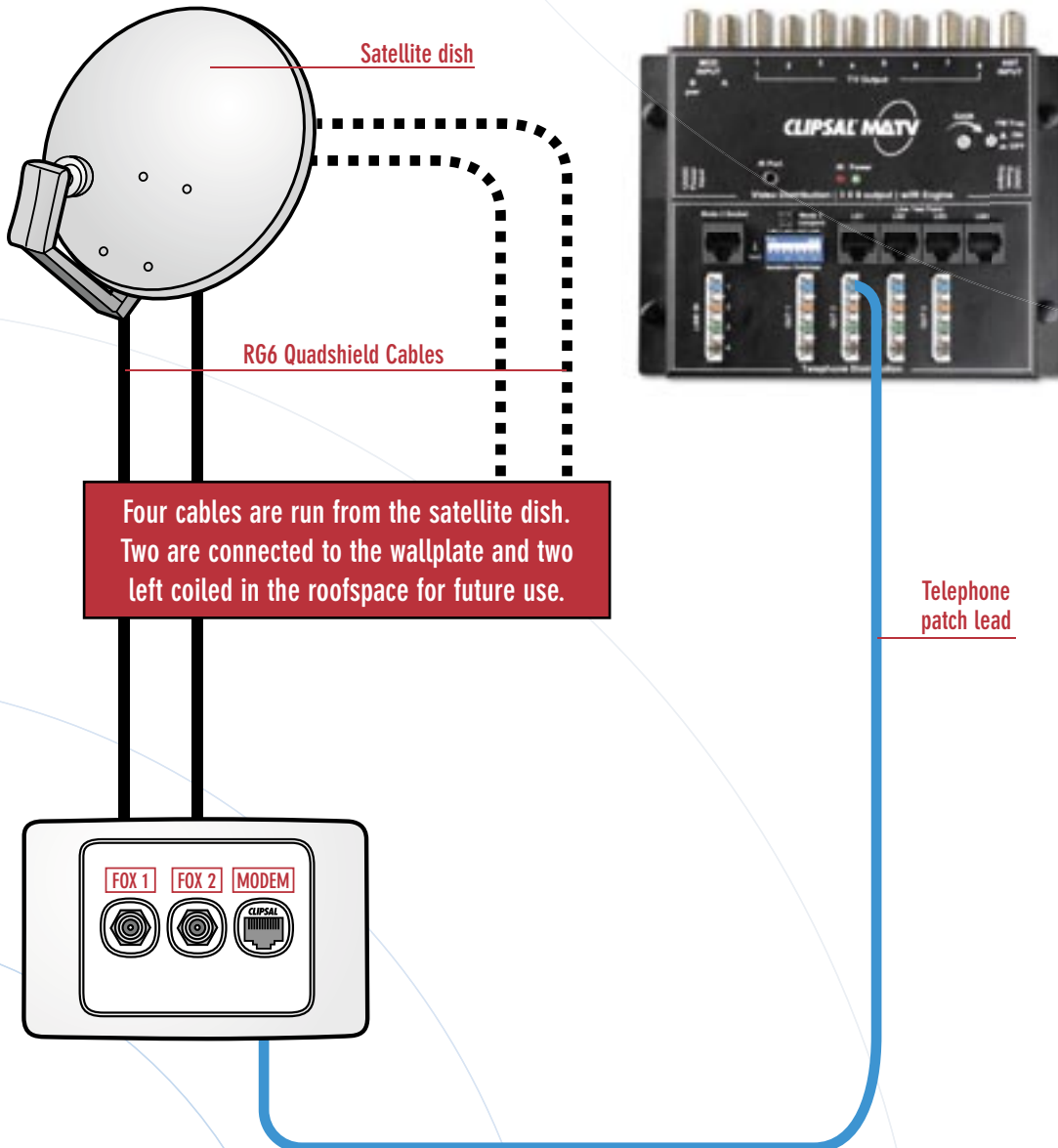

## Austar Cabling Requirements - Domestic

### AUSTAR COAX CABLING DOES NOT CONNECT TO CLIPSAL STARSERVE®

Austar require two Austar approved RG6 Quad Shield Coax Cables run from the satellite dish mounted on the roof to the location of the Austar decoder (2B6Q3B).

The cables must be connected with Austar approved F-Type Compression Connectors (3105RG6FC50). The cables must connect to Austar approved TV mechanisms (30PFM). A telephone outlet is required for the inbuilt modem of the Austar decoder for communication back to Austar for pay per view functions and billing.

Run a category or telephone cable from the Clipsal StarServe® to the Austar wall plate and terminate to the main telephone line.

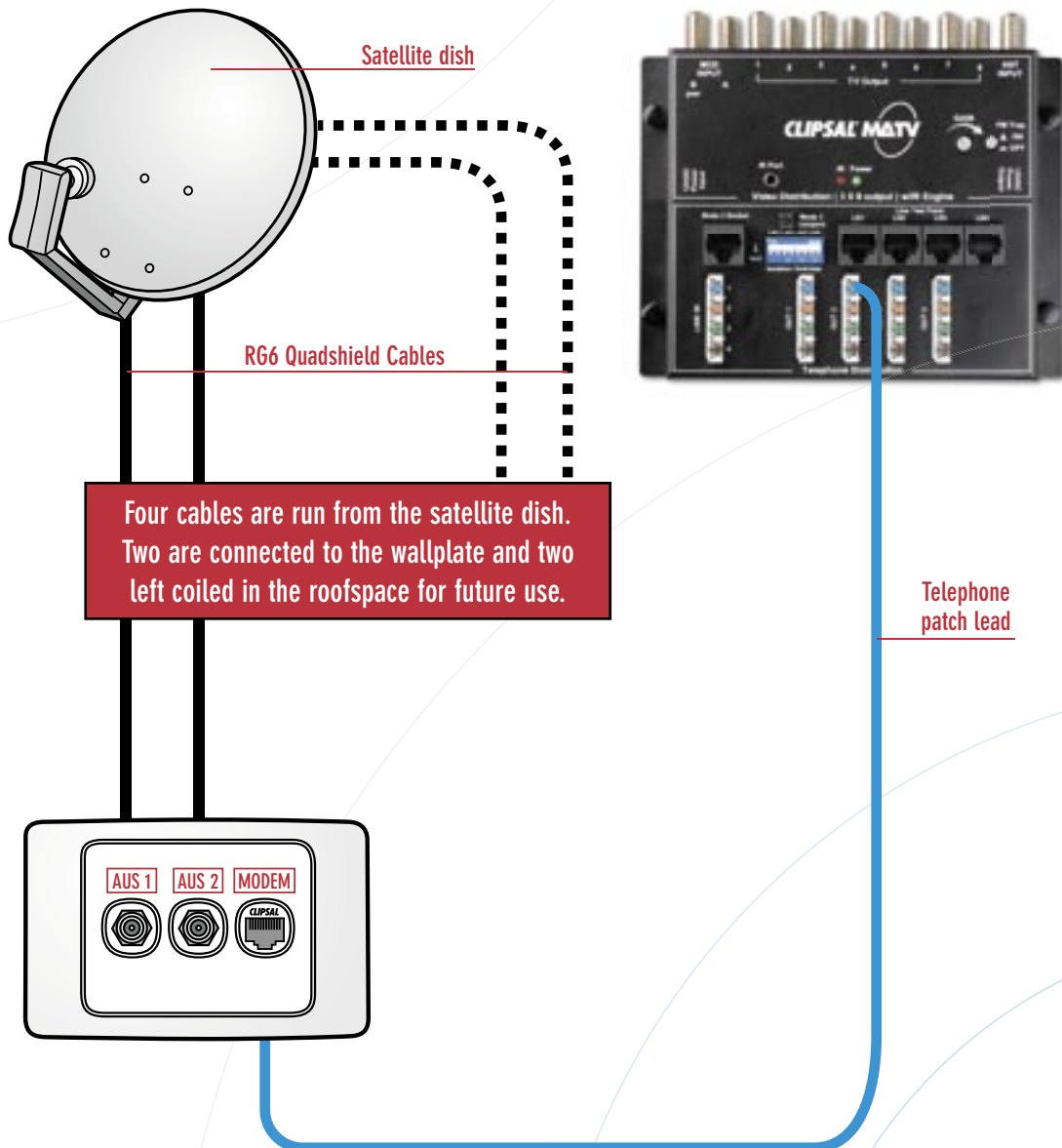



## Multiple Subscription TV Decoder Cabling Requirements - Domestic Installations

### SUBSCRIPTION TV COAX CABLING DOES NOT CONNECT TO CLIPSAL STARSERVE®

For multiple subscription TV outlets you will require a device called a multiswitch. The two cables from the satellite dish connect to the inputs of the multiswitch.

The two cables required by the subscription TV companies at the wall plate are then connected to the multiswitch outputs. The multiswitch is powered via the subscription TV decoder. Multiswitches are available in a number of configurations depending on the number of subscription TV outlets required (eg: four, eight, twelve outputs).

A telephone outlet is required for the inbuilt modem of the subscription TV decoder for communication back to the subscription TV provider for pay per view functions and billing.

Run a Category or telephone cable from the Clipsal StarServe® to the subscription TV wall plate and terminate to the main telephone line.

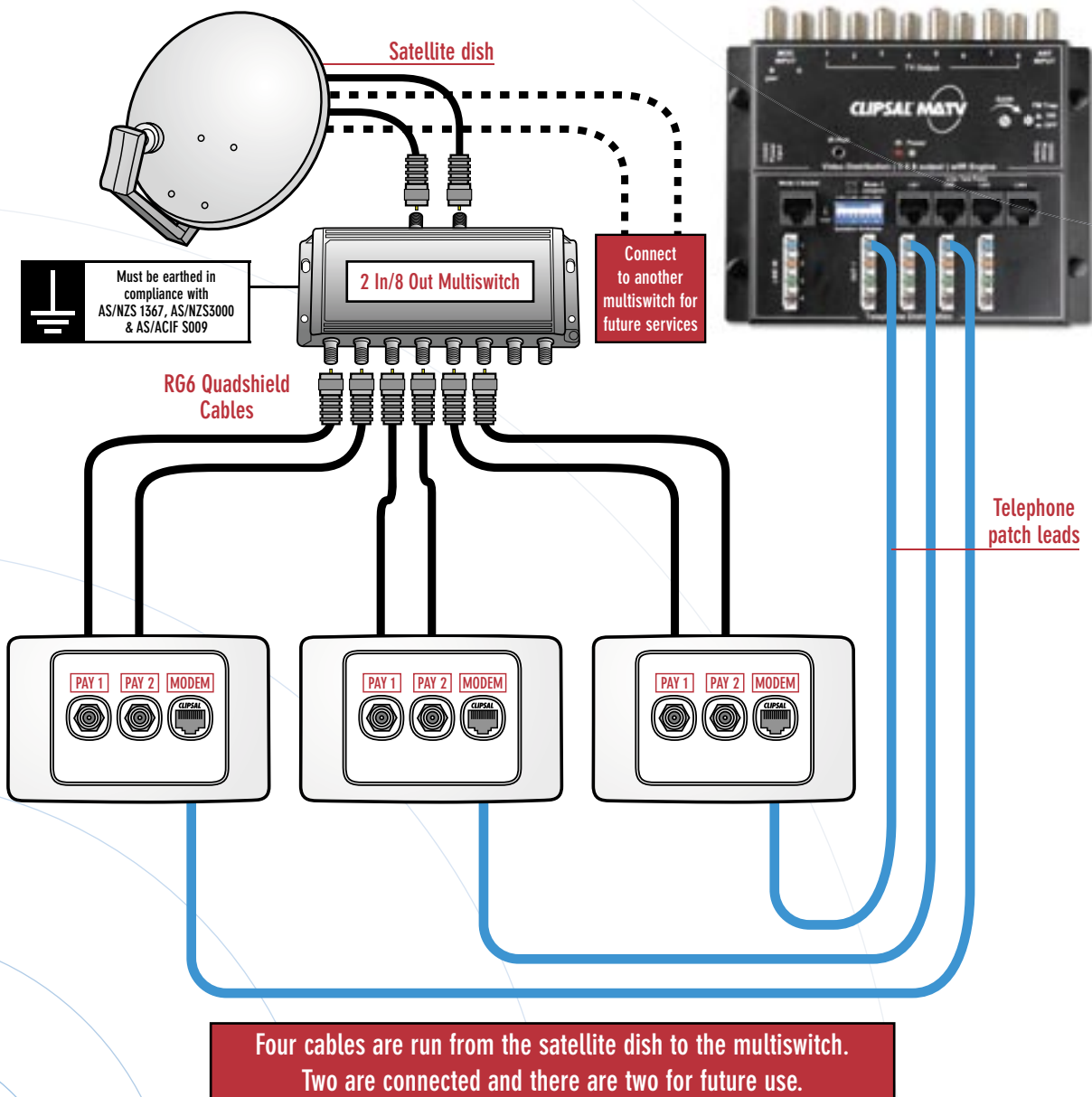

Apartment Cabling Requirements - Commercial Installations

SUBSCRIPTION TV COAX CABLING DOES NOT CONNECT TO CLIPSAL STARSERVE®

When cabling subscription TV into multistorey apartments you must cable from the riser to the apartment subscription TV location, 2 x subscription TV approved cables to the wall plate.

A telephone cable must be run from the Clipsal StarServe® to the subscription TV wall plate for subscription TV company's minimum cabling requirements.

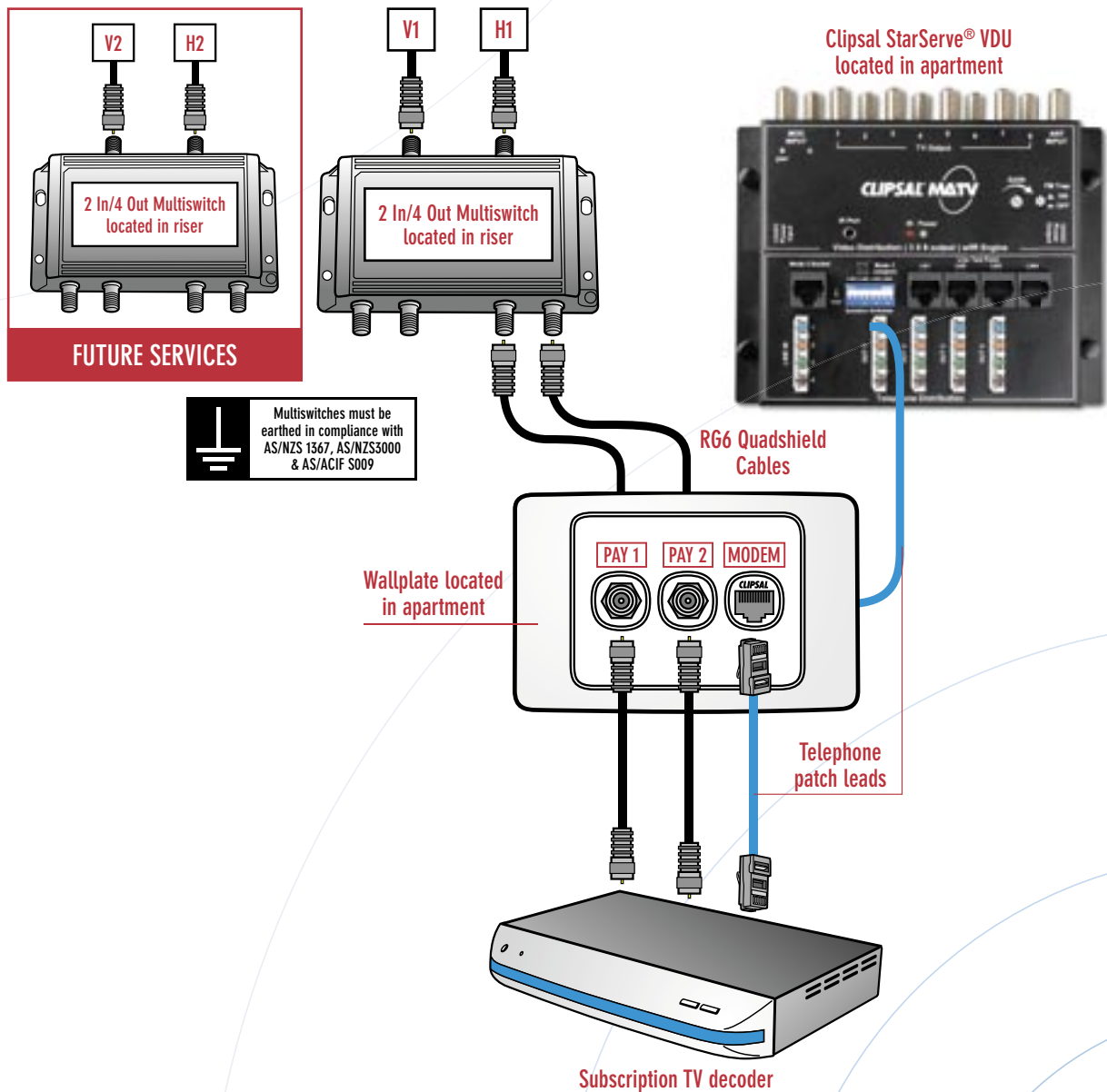

## Key Area 1 - The Lounge Room

The first key area is the location where the active devices such as the subscription TV decoder, DVD, VCR / DVR are located. The reason this is important is because we need to supply the DVR with a separate TV input so that the DVR can record without affecting the television in that room. The television in that room must also have a separate TV input.

To view the active devices in other rooms, the signals from these devices must be sent back to the Clipsal StarServe® VDU to be combined with the free to air signals going to the TV sets throughout the home. This then enables all the TV sets to view free to air TV plus DVD, DVR and subscription TV decoder signals.

A data outlet is required for technologies such as media centres that enable your computer to interact with your TV and stereo system.

### Typical Locations

The lounge room is a typical location for all of these devices and probably the most popular. In the home we generally have all of active devices in the lounge room, as it provides easy access to DVDs or watching subscription TV.

In some homes, the practice is to hide the active equipment in cupboards. As plasma screens become more affordable homeowners want to make it a feature on the wall and hide all the cables and boxes away from sight. Either way, you must have the cabling in the right location.

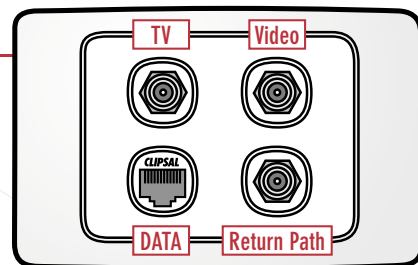

### Future Distribution of Services

Along with the standard wall plate you will require an additional four data cables on a separate wall plate. These four data cables are for the future distribution of video services.

This wall plate is highly recommended as the benefits of installing this while building will far out way the addition cost of installing it after the building has been completed.

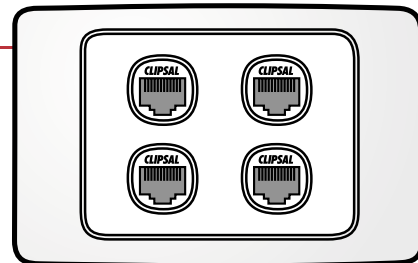

### Foxtel / Austar

As satellite TV becomes more popular, the benefit of installing cabling as you build becomes evident. If you have a two storey home it extremely difficult to install cabling after the walls are up. In some cases you cannot install extra cables unless you make holes in the walls. The added cost of the repair to the new wall after installation can be inconvenient and costly. It is wise to install the cabling during building as a safe guard. Many people have said they will never have subscription TV and the next thing you know they are making holes in walls and spending extra money when they had been advised to install it beforehand.

Both Foxtel and Austar will have the same cabling requirements for the service they provide.

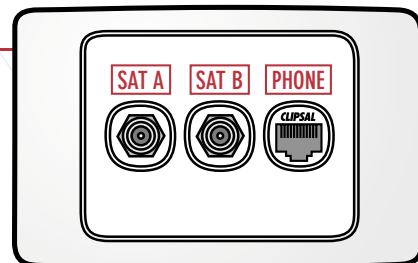

## Key Area 2 - The Master Bedroom

The master bedroom will have two wall plates as a minimum - one wall plate for TV and one wall plate for telephone. The TV wall plate will generally be located on the opposite side of the bedroom from the bed. This will enable the homeowner to watch TV in the bedroom in comfort as the TV is straight ahead. Most people these days will have a TV mounted on a TV bracket or on top of a dresser or even in a wardrobe.

### TV Wall Plates

All TV wall plates should have a minimum of one RG6 Quad Shield Coax Cable and one data cable. The future in video distribution is over a Category cable for active devices such as subscription TV, DVDs and DVRs. Coax will still be used for free to air TV. Modulators are currently used for the distribution of active devices.

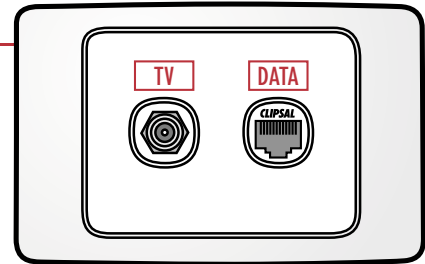

### Telephone Wall Plates

In the master bedroom the telephone outlets are generally located next to the bed on either side. You can have addition outlets for Internet access if you wish. Just install another cable from the Clipsal StarServe® Enclosure.

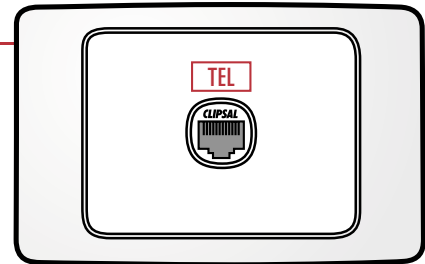

## Key Area 3 - Other Bedrooms

Other bedrooms are generally used by children. They do their homework in their bedroom and often when they get older they will have a TV in their bedroom. When planning for other bedrooms we need to make sure that we can have Internet access, telephone access and data network access to each room.

Clipsal recommend a minimum of one TV and two data outlets for each other bedroom but you may consider installing a third data outlet for future use. **SEE KEY AREA 4.**

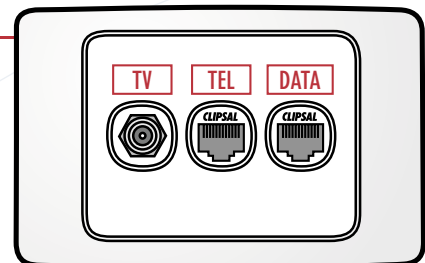

## Key Area 4 - Study/Other Bedrooms

The study or home office may require telephone, fax, Internet, data networking and TV access. To make sure all of services can be accessed we need to make sure we have enough cables.

Clipsal recommend a minimum wall plate configuration of one TV outlet and three data outlets. You can increase the number of data outlets depending on the demand for the services you may require.

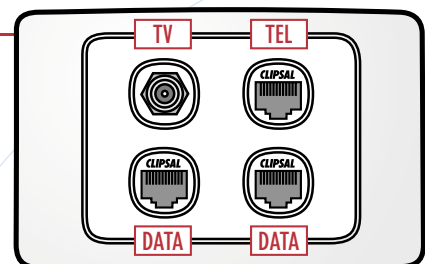

## Key Area 5 - The Kitchen

The kitchen will generally have a telephone outlet at the end of the breakfast bar. Many people will require an Internet outlet as well to allow access from the kitchen while preparing family meals or checking emails while having breakfast.

Internet fridges are also becoming popular as they come down in price. You may want to install a data outlet behind the fridge.

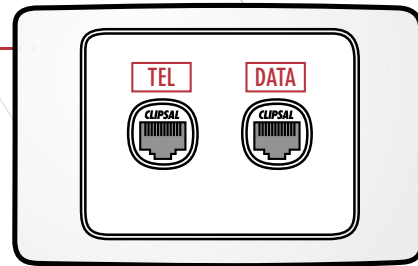

## Smart Wired Wall Plate

The SmartWired® group are recommending that you install a wall plate with two RG6 Quad Shield Coax Cables and two data cables. The reason for this is that you may require two coax cables for satellite services to every room. If this is likely, then make sure you cable for this service. This will leave a lot of unused cables in the Clipsal StarServe® Enclosure for potential future use.

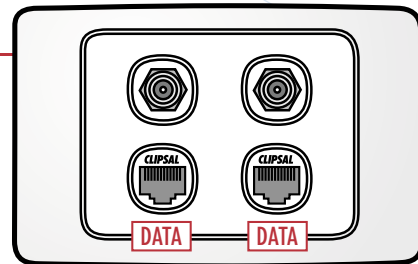

## Other Areas

Wherever you require a TV outlet, be sure to include a Category cable with it. The benefits will be evident as technology changes. This is not future proofing, as the technology is available today.

### TV Wall Plates

All TV wall plates should have a minimum of one RG6 Quad Shield Coax Cable and one data cable. The future in video distribution is over a Category cable for active devices such as subscription TV, DVDs and DVRs. Coax will still be used for free to air TV. Modulators are currently used for the distribution of active devices.

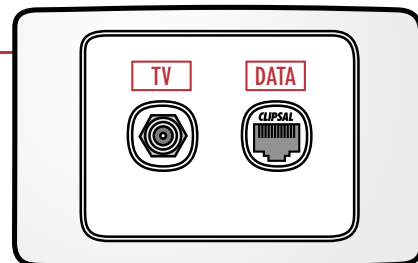

### Telephone Wall Plates

If you require a telephone outlet to any other location make sure that you think of Internet applications as well.

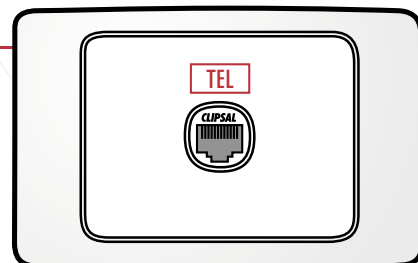

Clipsal Audio Solutions Product Introduction

3105SIMPS Stereo Input Module with Power Supply

The stereo input module is the connection between your audio source and your distributed audio system. The stereo input module also allows IR remote control of the source. You can control your audio source from other locations with a volume control connected to the Audio Solutions System.



3105VCRC,WE Volume Control with Remote

The volume control unit is the independent amplifier for an audio zone. It connects to the stereo input module via a Category cable and a figure 8 cable.

The Volume Control can perform the following functions:

- Turn On / Off
- Volume Up / Down
- Comes complete with a remote control to perform the above functions up to 15 meters from volume control
- Remotely controls the source using an emitter lead at the stereo input module and the source remote control.



3105ADJB Audio Distribution Junction Box

All cables are run to the Clipsal StarServe® enclosure from the volume control and stereo input module. The 3105ADJB is designed to fit into the Clipsal StarServe® enclosure range with power access.

Speaker Options, Tools and Cabling

<p><b>IN-WALL SPEAKERS</b></p> <p>5600IWK, WE Kevlar Drivers</p> <p>5600IWP, WE Polypropylene Drivers</p>	<p><b>TOOL KIT</b></p> <p>8520CPH Cable Cutters</p>	<p><b>CABLING</b></p> <p>14/020 AWG18 or 24/020 AWG20 FIG 8 Cable</p>
<p><b>IN-CEILING SPEAKERS</b></p> <p>5600ICK, WE Kevlar Drivers</p> <p>5600ICP, WE Polypropylene Drivers</p>	<p>3100RJA5V Punchdown Tool</p>	<p>2D4P5IPV5B, BU Category 5 Cable</p>
<p><b>OUTDOOR SPEAKERS</b></p> <p>5600ODP, WE</p> <p>5600ODP, BK</p>	<p>2.4mm flat head screwdriver</p>	<p>2SPK2C105 (1.5mm<sup>2</sup>) 2SPK2C259 (3.0mm<sup>2</sup>) Speaker Cable</p>





Infrared Control of the Source

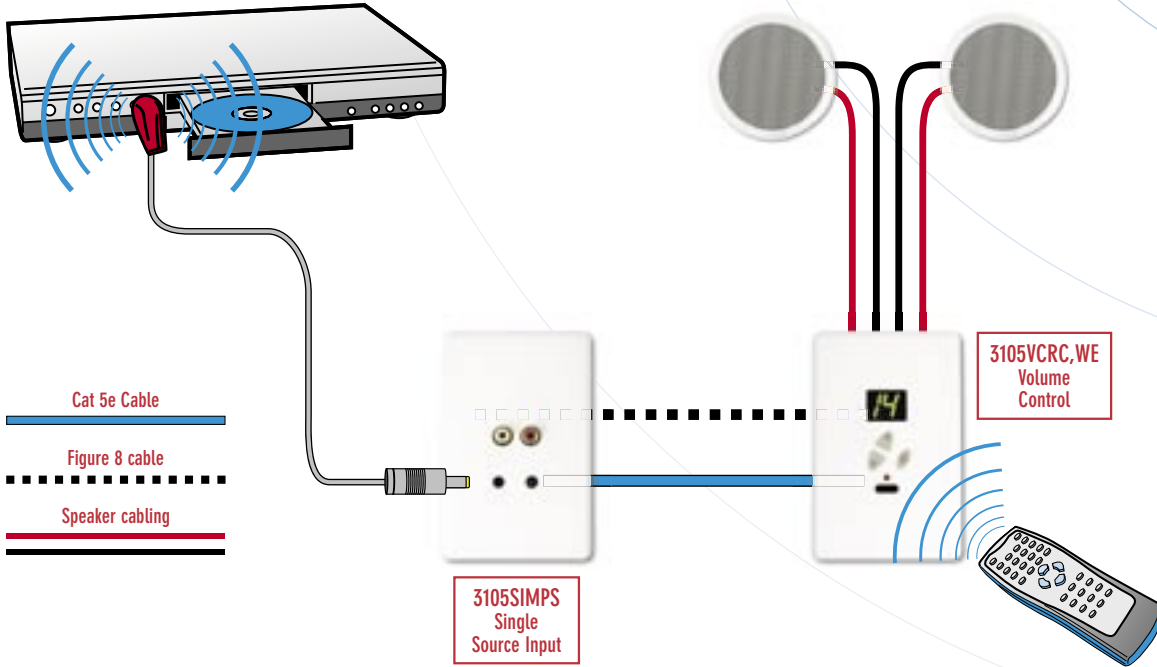

Clipsal Audio Solutions Wiring

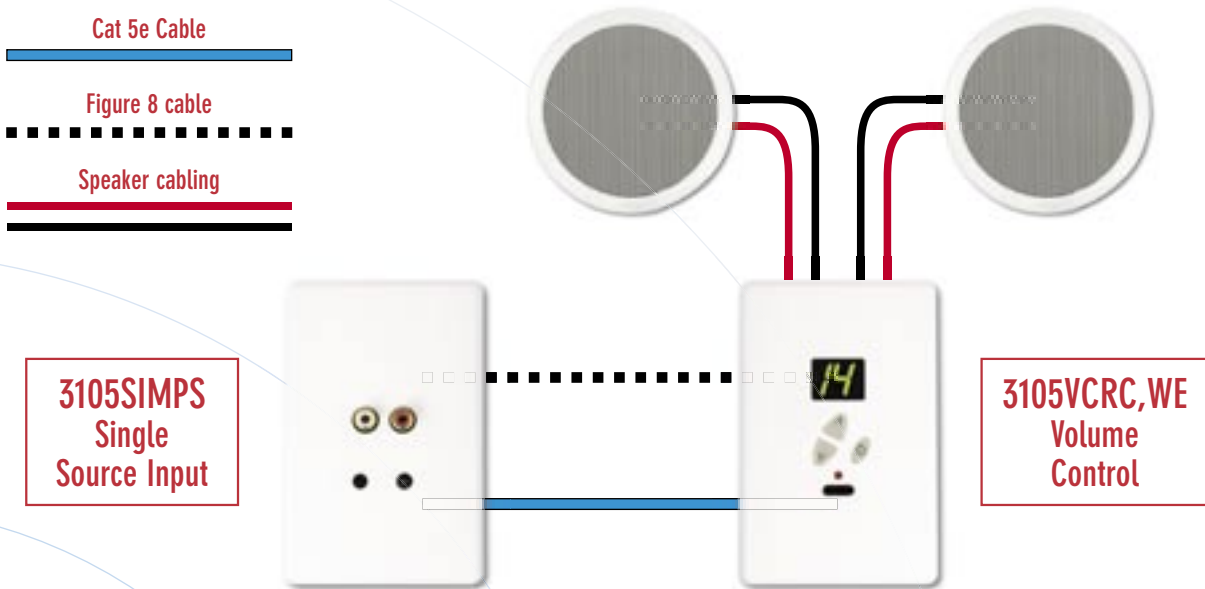

**AUDIO SOLUTIONS TROUBLESHOOTING**

**CABLING:** Check connections. Check the colour code is correct. Check the positive and negative cables are the same at both ends. Is the power supply connected?

**SOURCE:** Double check your source is in stereo. Do this by using either the left or right jacks only on both inputs to check.

INSTALLATION GUIDE





Clipsal Audio Solutions Loop Wiring

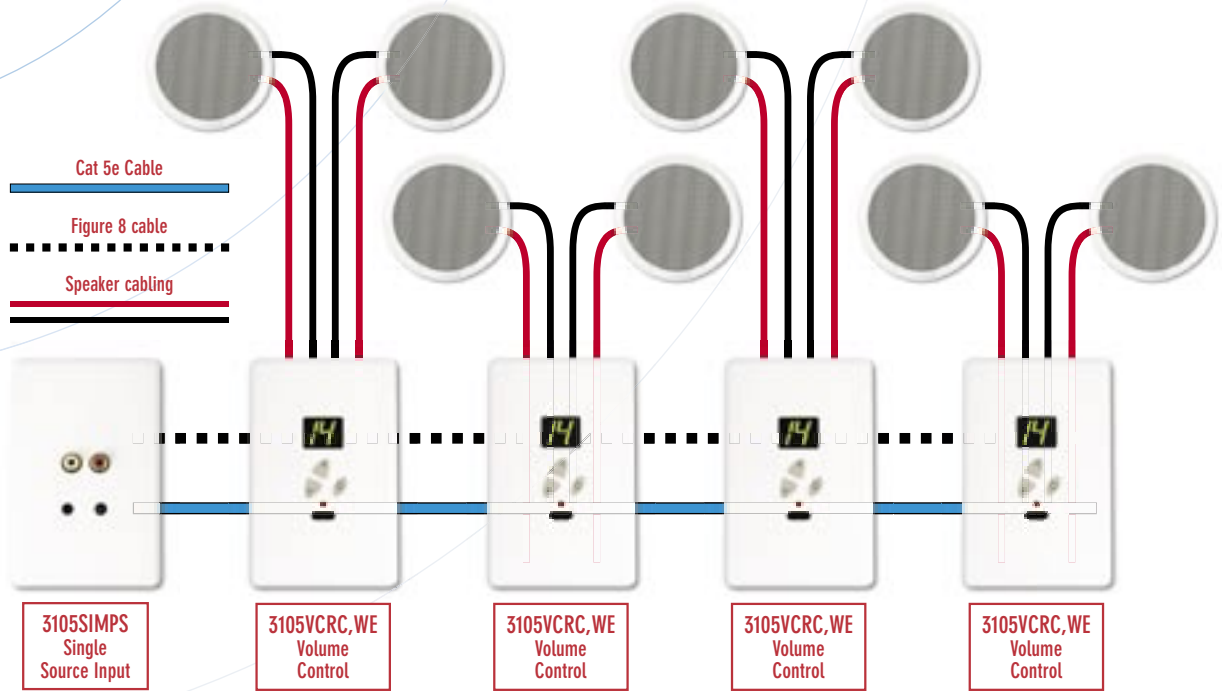

Clipsal Audio Solutions Star Wiring

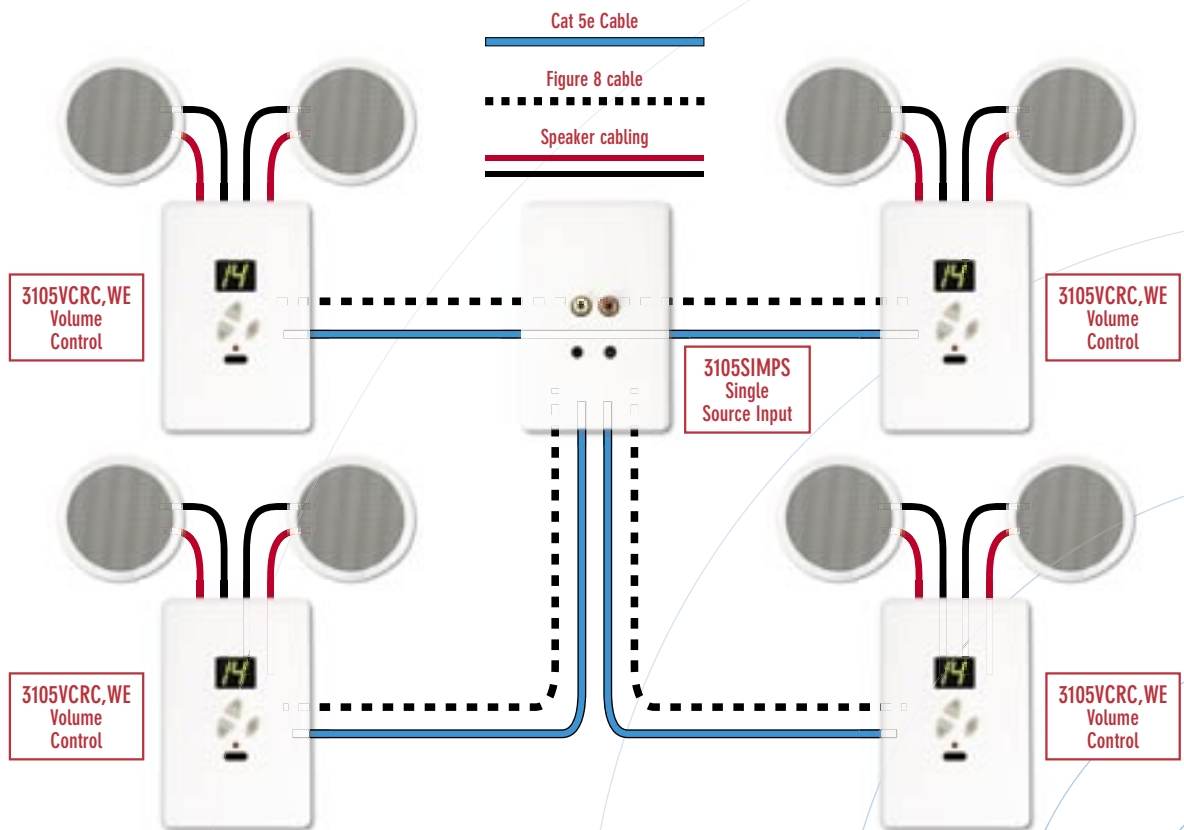

Clipsal Audio Solutions and Clipsal StarServe®

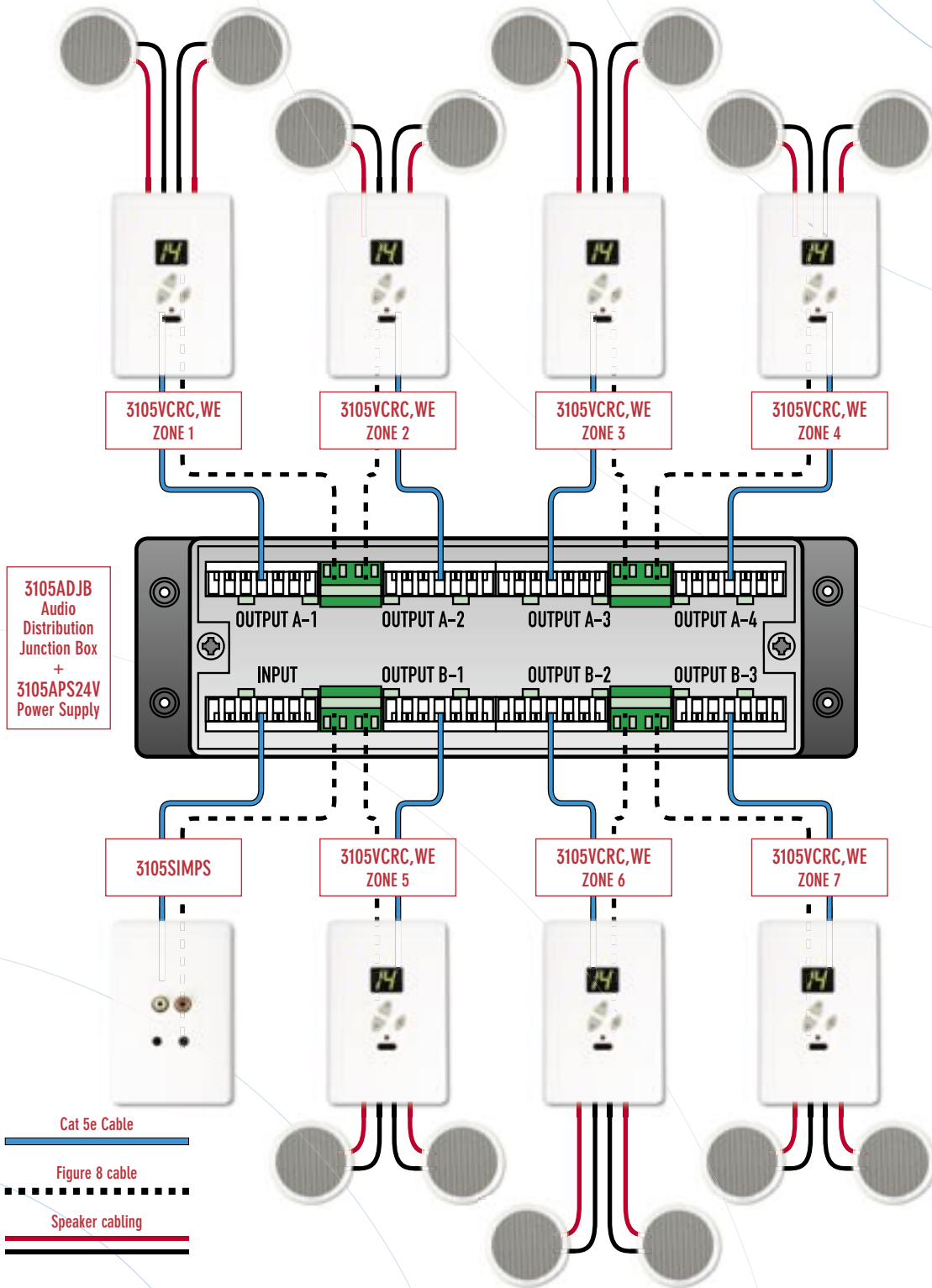

All cables are run to the Clipsal StarServe® enclosure from the volume control and stereo input module. The 3105ADJB is designed to fit into the enclosure range with power access.

STAR SERVE  
 THE CLIPSAL GROUP

## Infrared Troubleshooting Guide

### 1 IR Components

Are all the components IR compatible?

#### Modulator

- Must be 2 or 4 channel connected to "MOD INPUT B".

#### VDU

- Must be 3 in/8 out with inbuilt IR engine.

#### TV Outlets

- Must be a 30PFM.

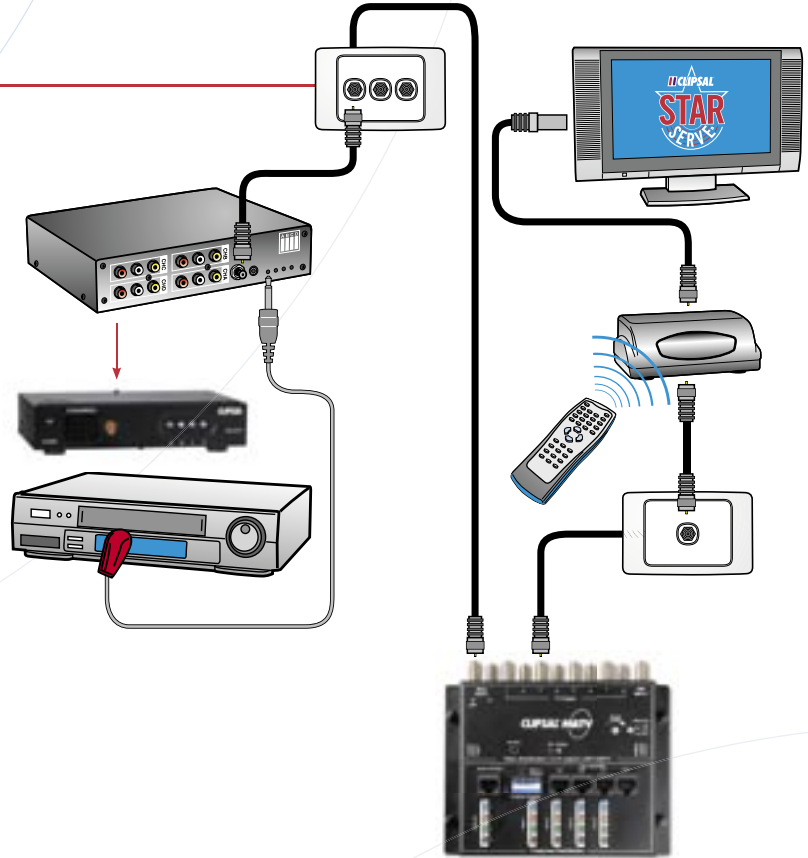

### 2 IR Remote Power Switch

Is the remote power switch on the modulator switched to the ON position?

- Remove any other power pack from the VDU and then switch to the ON position
- Make sure the Modulator is connected to "MOD INPUT B" at the VDU.

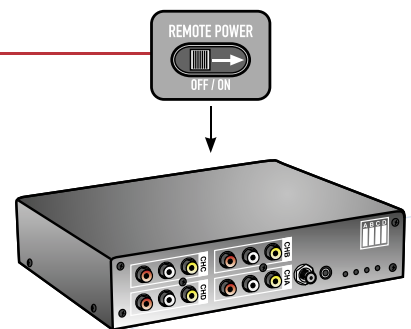

### 3 IR Emitter Lead

Is the emitter lead head over the IR pickup of the AV equipment?

- To locate the IR pickup of the device you wish to control, place your thumb over the suspected location of the IR pickup. Use the remote control to change channels, fast forward or skip. When you cannot change the status of the device you are directly over the IR pickup.

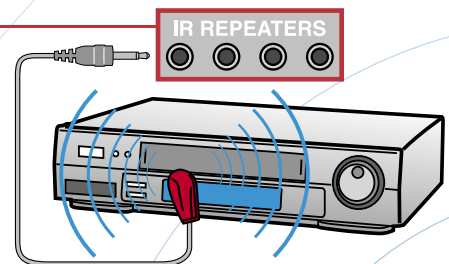

## Infrared Troubleshooting Guide

### 4 IR Target Location

Is the IR target too close to a plasma screen?

Position the IR target below the plasma screen to avoid the radiation drowning out the IR signal sent from the remote control.

You may need to adjust the position of the target on site depending on the amount of radiation the plasma screen emits.

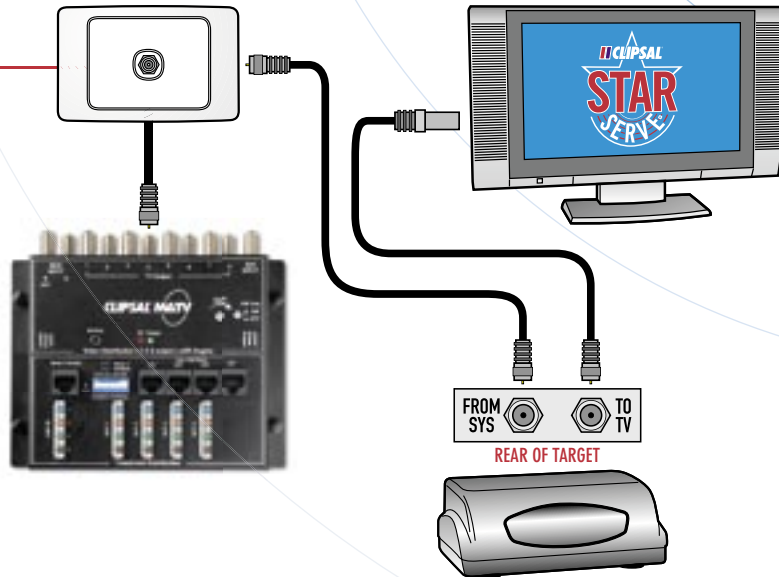

### 5 IR LED

Is the IR LED on permanently?

The IR target may be getting interference from a plasma TV.

- Remove the IR target to see if the LED goes out
- The connection of the cabling may have a short circuit
- Check your fly leads first
- Remove output cables from the VDU and replace one by one. If all outputs are removed and the LED is still on, it may be a short on the modulator cabling or the power supply of the modulator.



### 6 Clipsal StarServe® Service Agent

If you cannot solve the problem by following the first five steps, you may need to call a Clipsal StarServe® Service agent to fix the problem.

The Clipsal StarServe® Service Agent will rectify any faulty Clipsal StarServe® product at no cost to you or your customer.

If the fault is found to be an installation fault or an environmental fault, then the Clipsal StarServe® Service Agent will charge you directly for the call out and to rectify the problem.

**A faulty product is deemed to be a product that when installed correctly as to the manufacturers recommendations does not perform the function it is intended to perform due to the manufacturing process.**

## TV Reception Troubleshooting Guide - Free to Air Picture

### 1 Good quality signal strength at antenna input

Do you have a good quality signal strength of 69-89dBuV at the antenna input?

You must start with a quality TV signal before you try to distribute it to other TVs. The Clipsal StarServe® VDU distributes the incoming TV signal to multiple outlets - good Quality in means good quality out.

For difficult reception areas you may require a TV antenna specialist installer to give you a quality signal of 72dBuV at the antenna input.

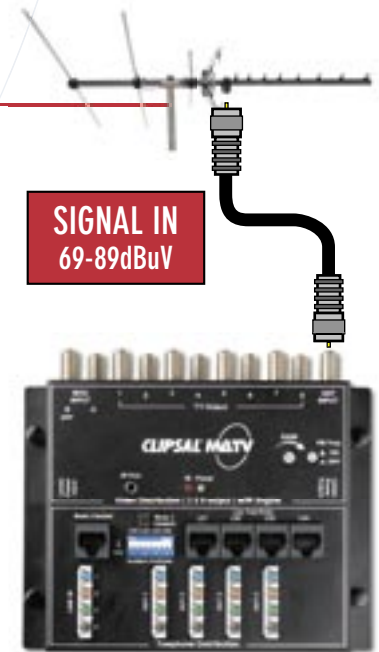

### 2 Output signal from VDU

Is the output signal from the VDU set at 72dBuV?

Use the variable gain control to adjust the output signal strength to 72dBuV.

For difficult reception areas you may require a TV antenna specialist installer to give you a quality signal of 72dBuV at the antenna input.

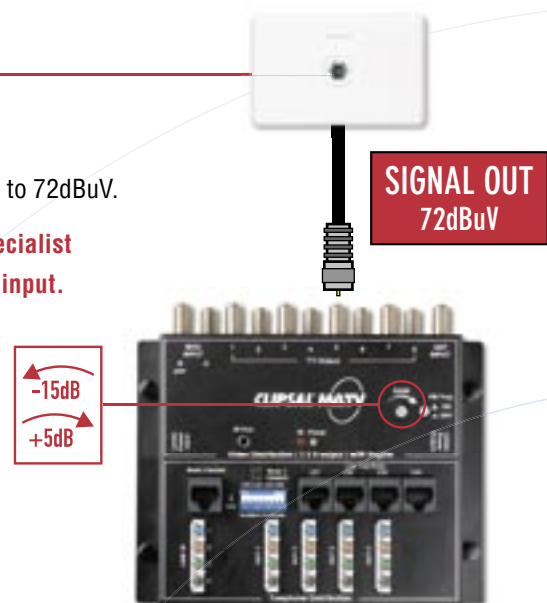

### 3 Modulator signal strength

Is the modulator signal strength within 15dBuV of the VDU output signal strength?

Lower signals may give a good picture quality to TV outlets but when a modulator is introduced into the system and the difference in signal strength is more than 15dBuV the picture quality will deteriorate.

For difficult reception areas you may require a TV antenna specialist installer to give you a quality signal of 72dBuV at the antenna input.

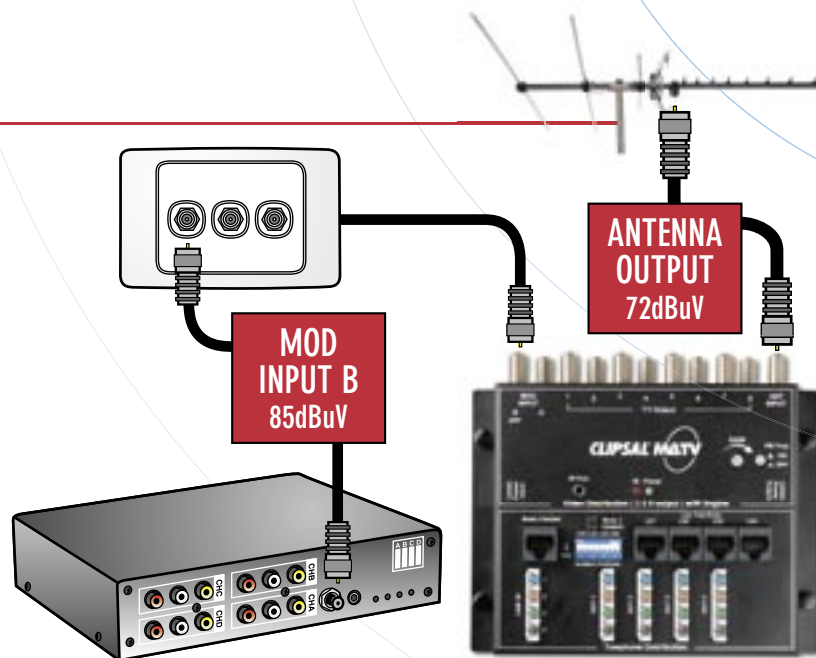

## TV Reception Troubleshooting Guide - Modulated Channels

### Modulated AV equipment channels are not clear?

Are the modulated channels at least 2 channels apart from any free to air TV channels being broadcasted in your area?

- Set the channels more than two channels apart from each other
- Check the **TV Across Australia** book for channels being broadcast in your area.

Do the Modulated channels have at least two channel separation?

- Example: **CH A = UHF 35 CH B = 37 etc...**
- Set the channels more than two channels apart from each other.



If you are using Y Leads or double adaptors and the picture seems to be washed out, you must make sure that the Hi-Z dip Switches are in the Hi-Z position. The reason for this is the Hi-Z dip switches ensure the impedance of leads are kept consistent with the requirements for video distribution.

## Clipsal StarServe® Frequently Asked Questions (FAQs)

---

### Preface

---

Clipsal StarServe® is a distribution system for TV, telephone and data networking. It is a simple system to set up and install. Here are some frequently asked questions on Clipsal StarServe®.

### Questions and Answers

---

**Q:** Can Clipsal StarServe® distribute digital TV signals?

**A:** **YES.**

**Q:** Does Clipsal StarServe® decode digital signals?

**A:** **NO. Clipsal StarServe® will distribute free to air digital signals to digital receivers. You will need a digital tuner to decode digital signals. This may be an inbuilt tuner or a digital set top decoder.**

**Q:** Can Clipsal StarServe® distribute DVD, subscription TV, video recorders and surveillance cameras?

**A:** **YES.**

**Q:** Does the Clipsal StarServe® modulator distribute digital signals?

**A:** **NO. The modulator distributes analogue signals. All TVs or tuners must be able to receive analogue signals to view modulated channels. Most new plasma screens with inbuilt digital tuners will accept analogue signals but may require a programming code to be entered. Digital modulators are in development and very costly to produce.**

**Q:** Can I remotely control my DVD, subscription TV and video from other rooms of the home?

**A:** **YES, via the IR target and emitter leads in conjunction with IR compatible products.**

**Q:** How many IR targets can be used on one Clipsal StarServe® system?

**A:** **You can have as many targets as the number of outputs on the VDU (eight) per VDU.**

**Q:** How many main entertainment area locations can be remotely controlled at any one time?

**A:** **ONE ONLY. The Clipsal StarServe® system is designed to distribute devices from ONE main entertainment area ONLY that can be remotely controlled. A total of eight devices can be remotely controlled from this location.**





- Q:** Can I remotely control devices not connected to the modulator from other rooms in the home using the Clipsal IR remote control facility?
- A:** **YES. You can control up to eight devices via the IR remote control feature of Clipsal StarServe®. Other devices may include stereo systems and amplifiers in the same location as other devices being remotely controlled.**
- Q:** Will the Clipsal StarServe® VDU distribute satellite TV signals?
- A:** **NO. Under NO circumstances is the Clipsal StarServe® VDU to be connected to the satellite TV coax cabling. Refer to the appropriate satellite TV cabling requirements. Satellite services will require multi switches for switching between vertical and horizontal polarities from the decoder to the satellite dish LNB.**
- The Clipsal StarServe® VDU will only distribute frequencies up to 1000MHz (free to air or terrestrial TV). The Clipsal StarServe® VDU will only distribute devices that have been modulated to VHF or UHF frequencies. Satellite signals must be distributed through a subscription TV approved parts list that is designed to accommodate satellite services.**
- Q:** Can I connect my subscription TV decoder directly to Clipsal StarServe®?
- A:** **NO. Under no circumstances is it recommended that any input device is connected to the Clipsal StarServe® VDU other than the appropriate products designed to be connected directly. Modulated outputs of devices (videos, subscription TV decoders) are low powered and not designed to be distributed over an extended length other than that of a fly lead.**
- Q:** Do you need an open registration licence to install Clipsal StarServe®?
- A:** **Only if you are connecting to the telephone network. If all you are doing is TV installation, then you do not need an open registration Cablers Licence.**
- If you are connecting to the telephone network or installing cabling that is to be connected to the telephone network then you must have the appropriate licence.**
- Q:** Are there training courses available for Clipsal StarServe®?
- A:** **YES. Contact your local Clipsal Australia Pty Ltd sales office for the next Clipsal StarServe® training course nearest you.**
- Q:** I have TWO entertainment areas that have DVD players and subscription TV Decoders - one upstairs and one downstairs. Can I remotely control both of them from any other TV in the home with an IR target?
- A:** **NO. You can only remotely control devices that are in ONE main entertainment area. Clipsal StarServe® has provision for four dual emitter leads that control up to eight devices in the one location. You may need to run another cable to the main entertainment area for the distribution of these devices and connect it to "MOD INPUT A".**



Notes





# INSTALLATION GUIDE



## CLIPSAL STARSERVE® SERVICE AGENT

Clipsal are introducing a Clipsal StarServe® agent to attend to calls received by contractors and consumers who are having installation issues with Clipsal StarServe®.

The service agent will repair any faulty Clipsal StarServe® product and Clipsal Australia will cover the cost of the replacement product and the time to rectify the fault.

If the fault is not the responsibility of Clipsal Australia, then the contractor or consumer will be charged to rectify the problem by the service agent.

All service agent callouts must go through the Clipsal Datacomms Call Centre where the call will be logged and a reference number allocated.

For further information call the  
Clipsal Datacomms Call Centre: **1800 728 728**

**Product of Clipsal Australia Pty Ltd**  
ABN 27 007 873 529

**Head Office**  
12 Park Terrace, Bowden  
South Australia 5007  
Telephone (08) 8269 0511  
Facsimile (08) 8340 1724  
Internet clipsal.com  
E-Mail plugin@clipsal.com.au

**National Customer Service Enquiries:**  
**1300 2025 25**

**National Customer Service Facsimile:**  
**1300 2025 56**

**International Enquiries**  
**International Sales and Marketing**  
Telephone + 61 8 8269 0587  
Facsimile + 61 8 8340 7350  
E-Mail export@clipsal.com.au

**New Zealand**  
**Clipsal Industries (NZ) Ltd**  
Telephone (09) 576 3403  
Facsimile (09) 576 1015  
E-Mail headoffice@clipsal.co.nz

**Customer Service**  
Free Fax (0508) 250 305  
Auckland/Mobile Phone (09) 572 0014  
Free Phone (0508) CLIPSAL  
2 5 4 7 7 2 5

You can find this brochure and many others online in PDF format at: [clipsal.com](http://clipsal.com)

Follow the links off the home page or access the following page directly:  
[clipsal.com/wat\\_lib\\_pdf.cfm](http://clipsal.com/wat_lib_pdf.cfm)

[clipsal.com](http://clipsal.com)

Clipsal Australia Pty Ltd reserves the right to change specifications, modify designs and discontinue items without incurring obligation and whilst every effort is made to ensure that descriptions, specifications and other information in this catalogue are correct, no warranty is given in respect thereof and the company shall not be liable for any error therein.

©Copyright Clipsal Australia Pty Ltd 2006.  
All rights reserved.