

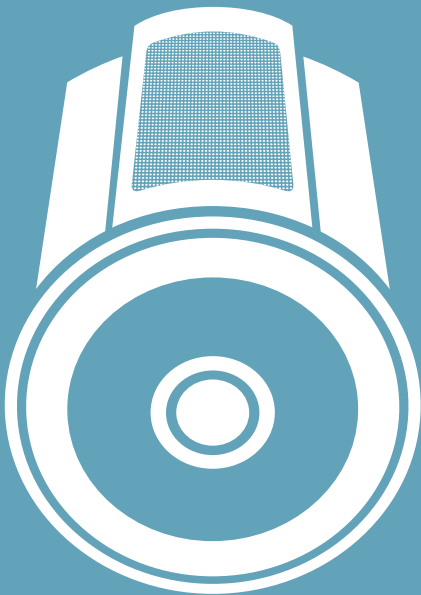

STRATOSPHERIX **AS**

INSTALLATION GUIDE



Congratulations on choosing Krix

Your Krix speakers are designed to reproduce the highest quality sound. To get the best performance from your speakers please read these installation instructions thoroughly as there are many factors that influence the performance of your speakers. If you have any difficulties please speak with one of our friendly authorised Krix dealers.

INSTALLATION

Before you begin



Please read the disclaimer on page 4 of this manual.

- Discuss with your local Krix distributor or installation consultant to determine the best location for your loudspeakers. Be sure to check for any obstructions, such as electrical wiring, plumbing, stud work or air conditioning ducts before commencing the installation. **(Figure 4)**

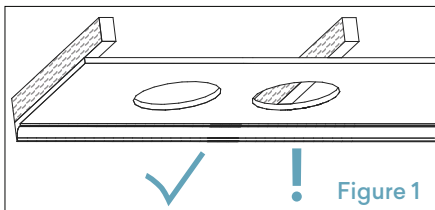

- Also ensure that there is enough ceiling/wall space to accommodate the speaker enclosure.

Connecting

To ensure optimum performance it is important that your speaker system is connected properly:



Turn off all electronic equipment and disconnect from the power point.

- Follow the connection instructions supplied with your amplifier, CD/DVD, hard disk recorder, video player etc.
- Install speaker cable in wall or ceiling cavity, or run cable along wall surface. Allow approximately 300mm of excess cable to facilitate loudspeaker installation.
- Follow the connection instructions supplied with your amplifier to connect the speaker cables to amplifier. Take care to assign the same cable colour or trace to the positive (+) connector on the amplifier as the positive (+) connector on the speaker.
- Prepare speaker cables for connecting to speakers by neatly stripping cable ends.



Care should be taken to **eliminate loose strands of wire** that may be present a short circuit hazard.

Installation

- Once the correct placement of the speakers has been determined, use the cardboard insert marked 'template' (from the internal packing) to trace the required cut-out onto the ceiling/wall. **(Figure 4)**
- Drill a hole inside the marked cut-out. Using a fine gyprock saw, cut around the inside of the marked cut-out. **(Figure 5)**
- Remove the circular offcut and insert the speaker to check the hole is the correct size. Enlarge the cut-out if required.
- Pull the stripped speaker cable through the ceiling/wall opening. Push and hold down the positive (+) red binding post on the speaker and insert the positive (+) wire through hole. Take care to assign the same cable colour or trace to the positive (+) connector on the amplifier as the positive (+) connector on the speaker. Repeat connection process with the negative (-) black binding post and the negative (-) wire. **(Figure 6)**
- Ensure all mounting clamps are swung back against the speaker enclosure **(Figure 6)**, so that the speaker can be easily inserted into the ceiling cut-out.
- Once the speaker has been located in the ceiling/wall, use a Philips head screwdriver to tighten all mounting screws. As the screws are tightened, the mounting clamps will automatically swing out over the gyprock and clamp the speaker in place. Be careful not to over tighten the screws as this may strip the clamp or crush the gyprock surface. **(Figure 7)**
- Gently fit the magnetic grille to the front of the speaker housing. **(Figure 8)**

Painting

If the speaker grille requires painting it is recommended to use a spray can for ease of application. Alternatively, it is possible to apply acrylic or enamel paint using a small foam roller but this will require more applications to achieve a good result.

Spray can application

- Use a spray can and apply a light coat of paint. Rotate the product at 90° intervals and apply three more light coats to ensure an even coverage.
- Be careful in applying single heavy coats of paint as there is a higher probability of blocking the holes in the grille.
- If the grill does become blocked by paint, use a small pin or similar to release the blockage, while the paint is still wet.

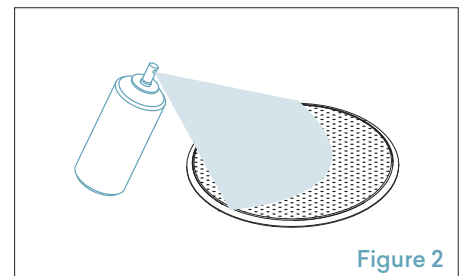

Roller application

- Peel away and discard the fabric liner from inside the grille.
- Load a foam roller with a light coverage of thin paint and then roll onto the grille. Try to avoid blocking the holes in the grille. If the grille does become blocked by paint, use a small pin or similar to release the blockage, while the paint is still wet.
- Allow the paint to dry. Apply three or more light coats to ensure an even coverage.

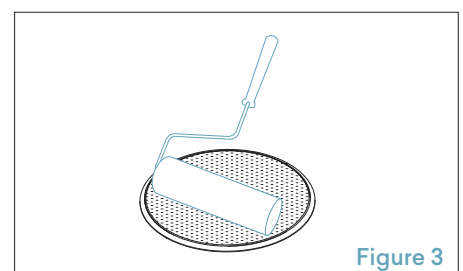

INSTALLATION

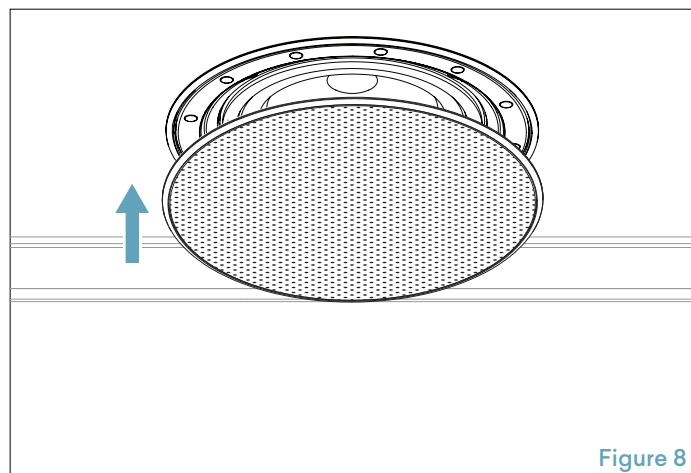
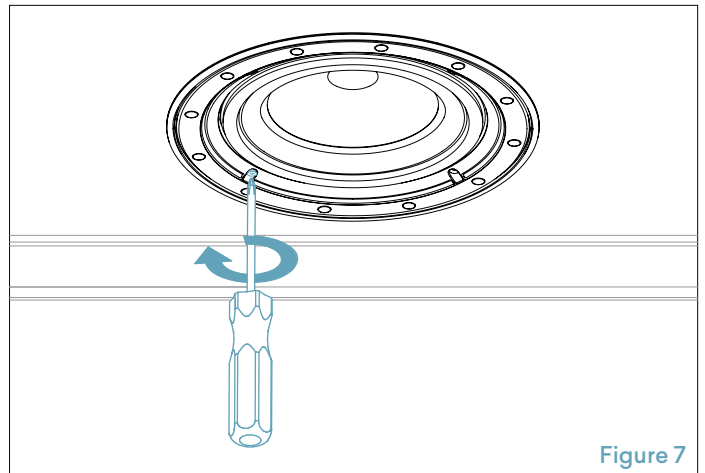
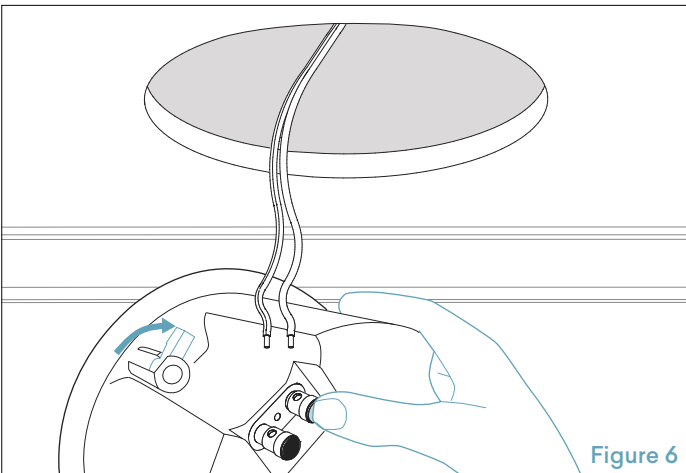
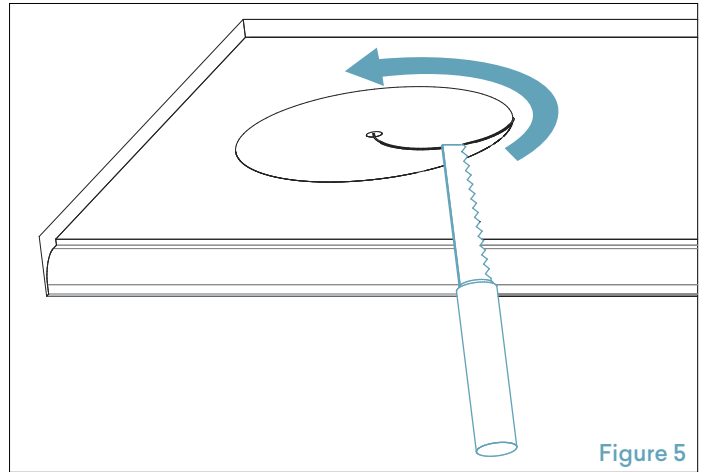
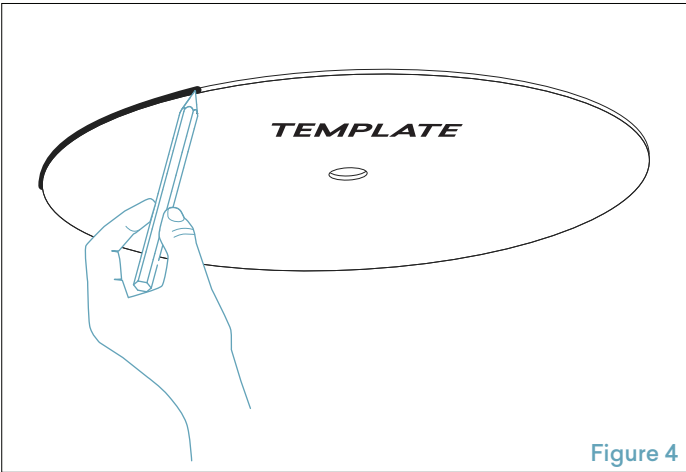



Krix Loudspeakers Pty Ltd
14 Chapman Road
Hackham SA 5163
Australia

T 61 8 8384 3433
F 61 8 8384 3419
listen@krix.com

Doc. Rev. # 10001

krix.com



Disclaimer

Cutting or drilling into anything can be dangerous. You should make sure you know what is behind or inside the surface that you are cutting into before you start to cut. For example, you might strike an electrical cable. If you do not feel entirely confident about installing this product, contact a professional installer.

Disclaimer

To the extent permissible by law:

All warranties, conditions, representations, promises and statements relating howsoever to this product whether express or implied and whether in contract or tort are excluded to the extent permitted by law; and

Our liability to you under a condition or warranty (if any) implied into this sale and purchase agreement relating to this product by the Trade Practices Act 1974 (as amended) or any other law (whether a law of Australia or any other country) other than a condition implied by Section 69 of the said Act is limited at our option to:

- the replacement of the product; or
- the supply of an equivalent product; or
- the repair of the product.

If you do not accept the above conditions, return this product (in the original packaging) with proof of purchase for a full refund.