

# Owner's Manual

## Epix - Back Box

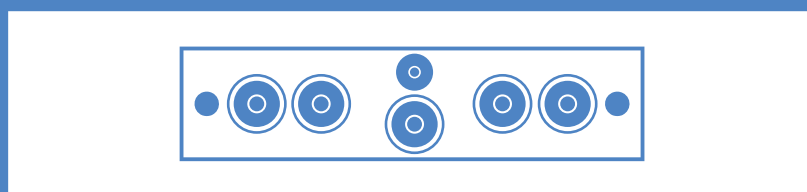
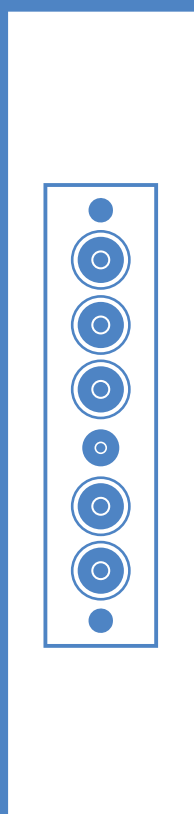

## setup in brief

---

*The following setup procedure will help you achieve the best performance from your inwall speaker:*

### 1. unpacking

Remove your speaker from the packaging

### 2. before you begin

Ensure correct tools are used and precautions are made

### 3. positioning

Determine a suitable location for your speakers and prepare studwork to accommodate speaker enclosures

### 4. installation

Attach speaker to studwork and connect cabling

### 5. listen and enjoy

Listen to your favourite music/movies and enjoy.



#### disclaimer

Drilling into anything can be dangerous. You should make sure you know what is behind or inside the surface that you are drilling before you start to drill. For example, you might strike an electrical cable.

You must use appropriate fixings for the surface that you are fixing to. If you don't, injury or damage may occur.

If you do not feel entirely confident about installing this product, contact a professional installer.

#### Disclaimer

To the extent permissible by law:

All warranties, conditions, representations, promises and statements relating howsoever to this product whether express or implied and whether in contract or tort are excluded to the extent permitted by law; and

Our liability to you under a condition or warranty (if any) implied into this sale and purchase agreement relating to these brackets by the Trade Practices Act 1974 (as amended) or any other law (whether a law of Australia or any other country) other than a condition implied by Section 69 of the said Act is limited at our option to:

the replacement of the product; or  
the supply of an equivalent product; or  
the repair of the product.

If you do not accept the above conditions, return this product (in the original packaging) with proof of purchase for a full refund.

# before you begin

---

## New Construction

The Krix Epix inwall speakers have been developed to suit 45x90mm or 35x90mm timber stud construction.

 The speakers must be installed before the plasterboard is installed.

To allow the speakers to be installed at the optimum positions in the wall, timber stud positions should be mapped out prior to construction by the installer (see page 5).

## Retrofit

Retrofitting of the Epix is possible in 90mm studwalls.

Retrofitting requires removal of large sections of plasterboard and possible repositioning of studwork, wiring etc. to accommodate the speakers' large MDF backboxes.

## False Walls

Where existing walls are unsuitable for retrofitting, or timber stud construction is not used, installers may consider creating a false timber stud and plasterboard wall to accommodate the Epix boxes.

## Tools Required

Electric drill  
No.2 (medium) extended Phillips Bit  
Level (optional)  
Medium phillips head screw driver  
Plasterboarding tools  
- Drywall saw, flushing compound etc

## Safety

It is recommended that the Krix Epix is installed by a qualified installer.

Due to the size and weight of the Epix it is recommended that at least two people install the Epix enclosure into the studwork.

# positioning

## front left and right speakers

As a guide, the placement of left and right speakers used for two-channel stereo should form an equilateral triangle with the primary listening position. In many situations room layout and speaker mounting may require the front speakers to be positioned closer together than this recommendation. Excellent results are often achieved in these situations. It must be noted however, that placing front speakers too close together can result in the sound becoming monophonic and lacking depth.

## centre channel speaker

Position the centre channel speaker above or below your television. Ideally the centre channel speaker should aim at ear level when seated.

If an acoustically transparent screen is to be used, a vertical center channel speaker may be placed behind the screen. In this configuration it is suggested that the grille is removed from the product. (see page 5.)

## rear speakers

Rear speakers (for home theatre) should be placed to each side and/or behind the listener. Exact positioning will be dependant on your room layout and the number of surround/rear speakers in your system (e.g 5.1, 6.1, 7.1 and beyond).

## loudspeaker dimensions

\*Do not build studwork with 390mm spacing. The enclosures have been optimised for use with 450mm stud centers (see page 5). This will result in a 5-20mm gap between the speaker and the stud, which helps to reduce transmission of vibrations between the loudspeaker and the studwork.

\*\*Exact dimensions are provided for the front baffles. When cutting the plasterboard allow an extra 3-5mm of clearance for the pre-installed plasterboard metal capping (see page 9).

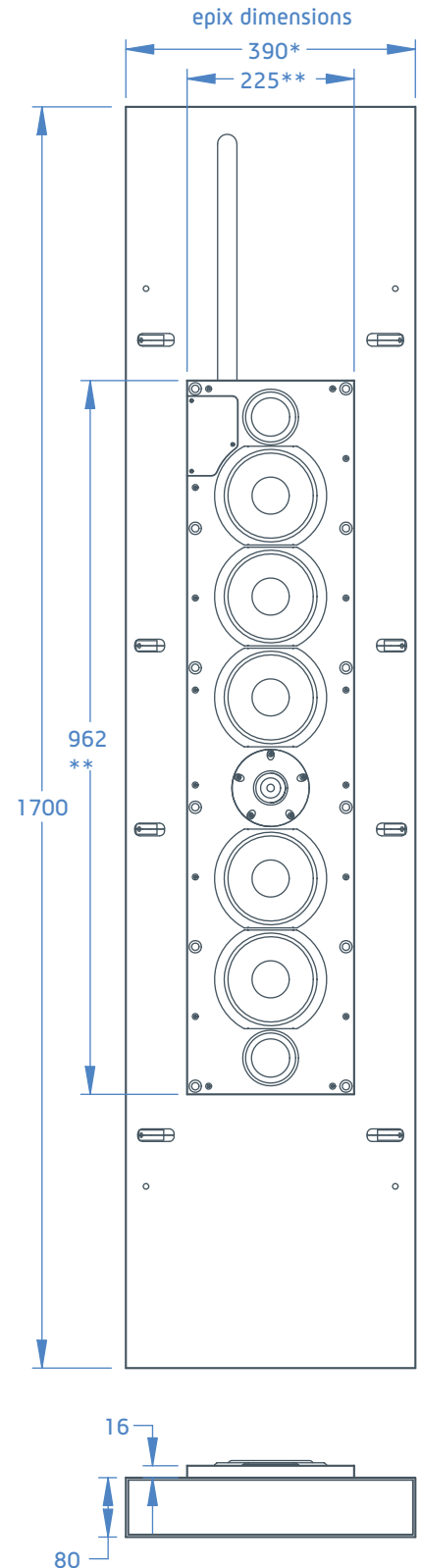

# positioning

## studwork preparation

Below are recommendations for constructing a suitable timber stud frame for the Epix. Consult with a professional installer for further recommendations.

Refer to page 6 for recommendations when using acoustically transparent screens.

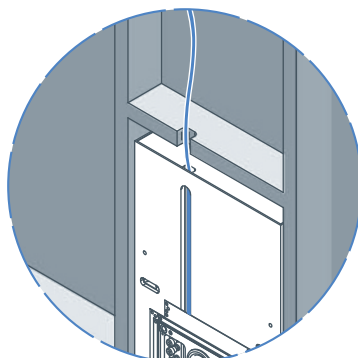
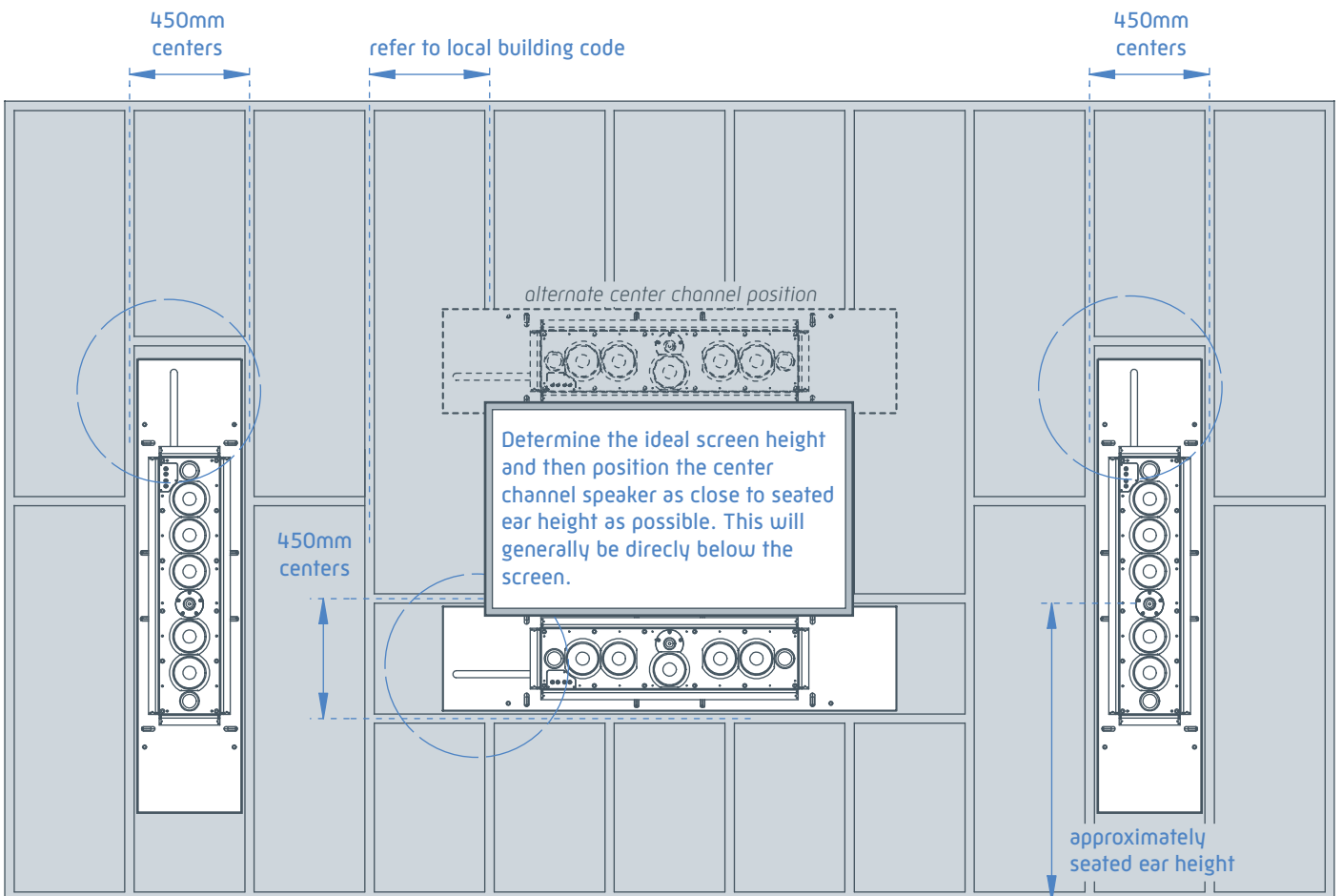

Ensure a clear path is maintained for cable insertion

## positioning - acoustically transparent screens

### studwork preparation

Below are recommendations for constructing a suitable timber stud frame when using an acoustically transparent screen. The diagram below shows a vertical Epix used as a center channel. In certain installations it may also

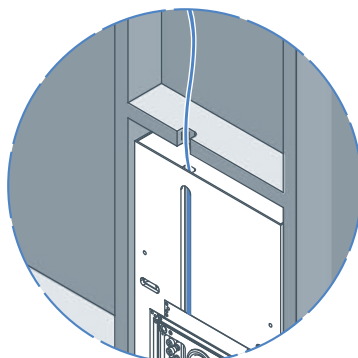
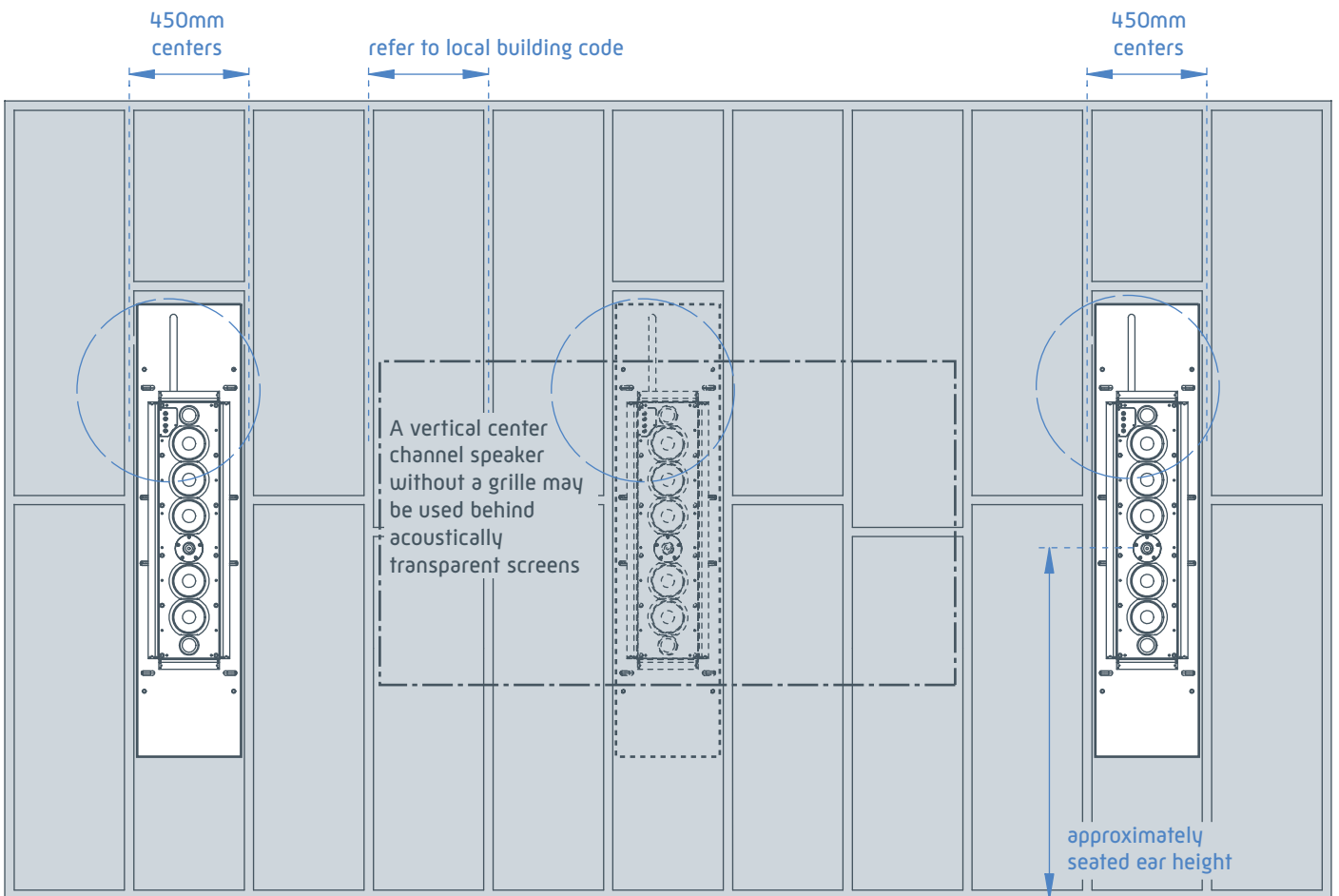

be appropriate to install left, center and right speakers behind the screen. Consult with a professional installer for further recommendations.



Ensure a clear path is maintained for cable insertion

# installation

## install enclosure using temporary braces

1.  The installation braces are supplied factory fitted for 10mm plaster board installation. If 13mm plasterboard is to be used, follow the instructions printed on brace. This ensures the front baffle of the speaker will sit flush with the plasterboard wall.  
 Ensure installation brace bolts are tight before proceeding.
2. Ensure speaker enclosure is level.
3. Fix temporary braces to studwork using supplied zinc Phillips head screws.

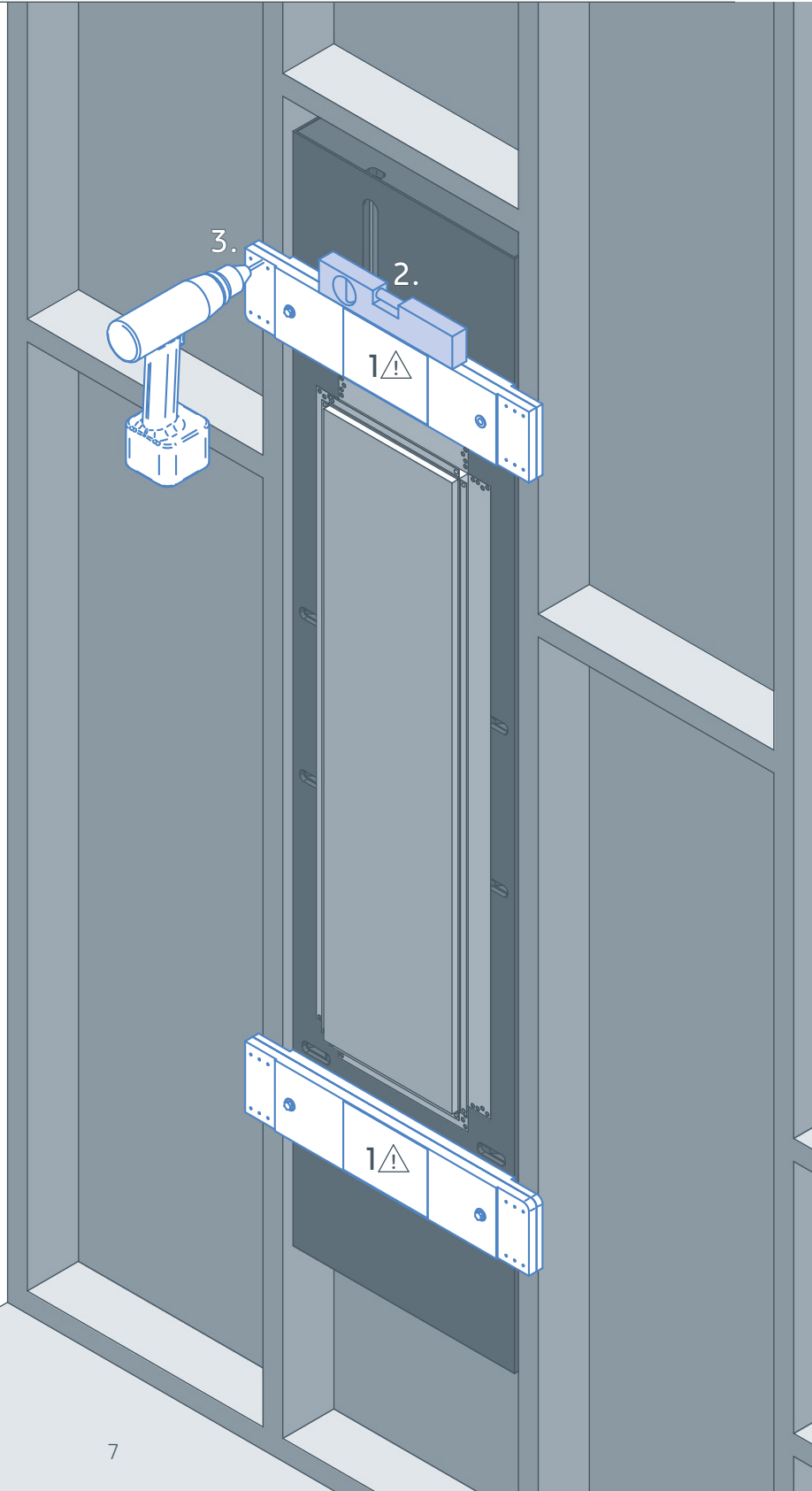

# installation

## install timber Phillips screws

4. Install the coated Phillips drive screws using an extended Phillips bit.

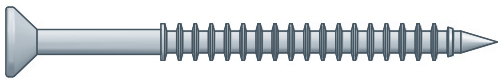

8 x coated Phillips drive

5. Removed temporary cross braces

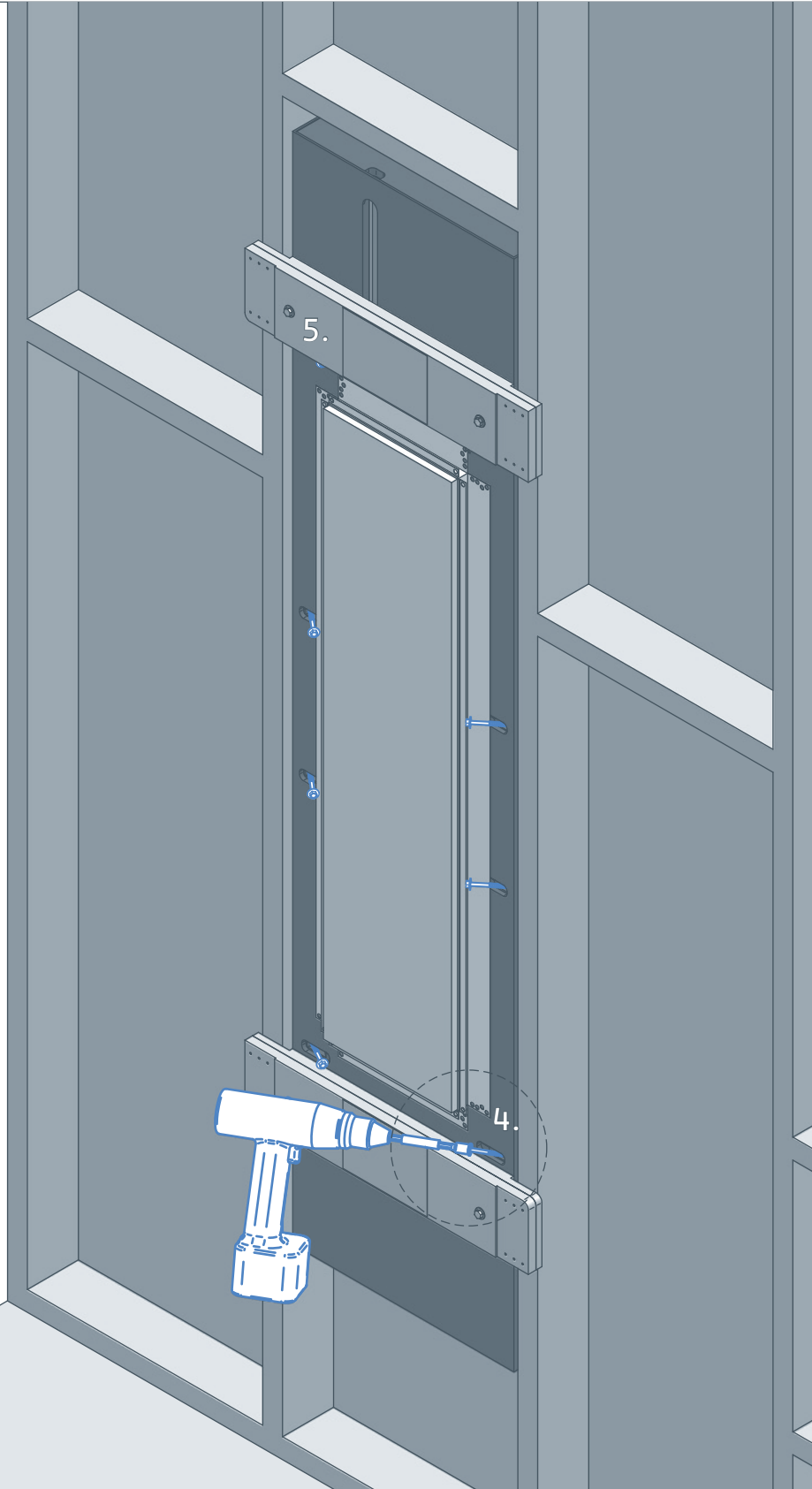
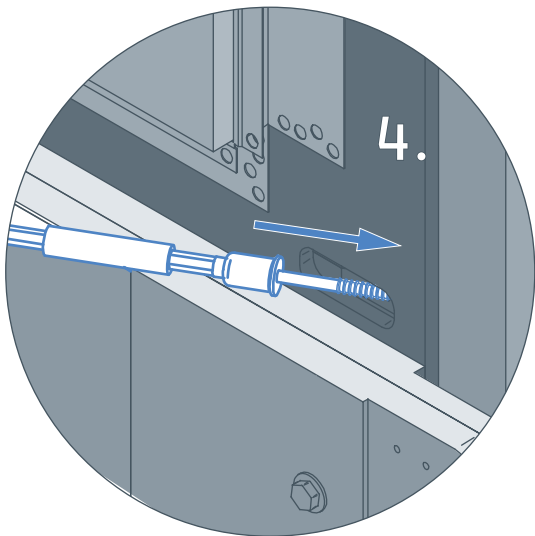



# installation

## routing speaker cable

6. Route speaker cable through studwork to speaker.
7. Securely screw cable into to binding posts. Take care to assign the same cable colour or trace to the positive (+) connector on the amplifier, as the positive (+) connector on the speaker. Repeat connection process with negative (-) binding post and negative (-) wire.

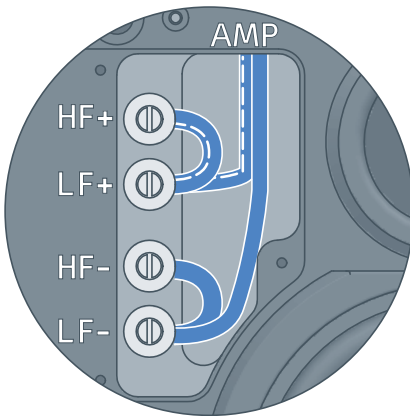

### **Single Pair**

When using single pair cable, LF- and HF- must be bridge and LF+ and HF+ must be bridged.

⚠ Note if bridging connections are not made, the speaker will not produce both bass and treble.

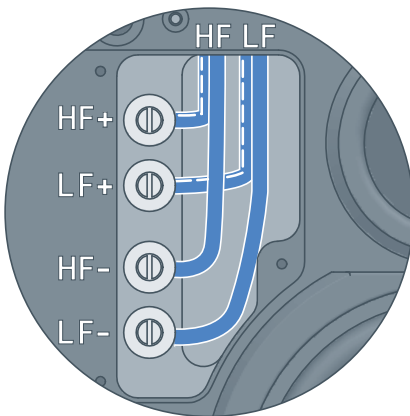

### **Bi-Wire**

When Bi-wiring the Epix connect LF and HF cables to the corresponding binding posts.

# installation

## installing plasterboard

- 8. Cut plasterboard to size and slide under metal edging.
- 9. Attach plasterboard to stud work.
- 10. Using flushing compound flush over metal capping.
- 11. Paint plasterboard wall.

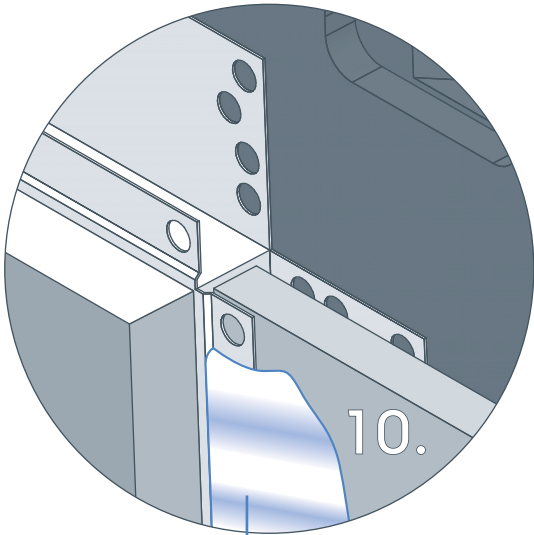

flushing compound

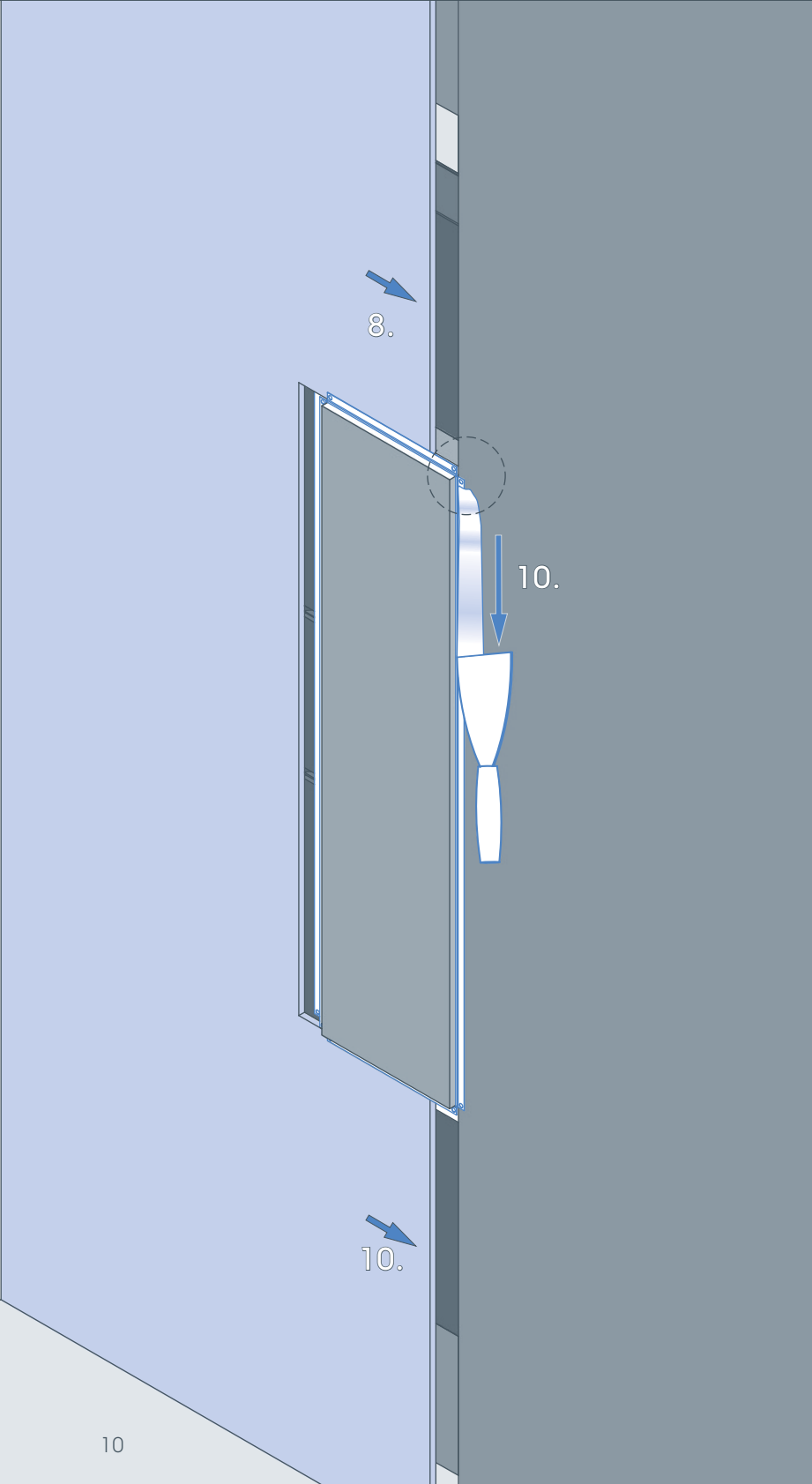

# specifications

## Epix: specifications

Frequency Range	40Hz - 40kHz in room response
Power Handling	Maximum 200 watts RMS amplifier power into 4ohms
Sensitivity	90dB for 2.83 volts at 1 metre
Configuration	6 driver 3-way bi-wireable / bi-ampable
Bass Drivers	4 x nominal 130mm (5") coated paper cones. 26mm (1") voice coil wound on high powered aluminium former provides good linearity and driver control at large cone excursion.
Midrange Driver	1 x nominal 130mm (5") coated paper cone. 26mm (1") voice coil wound on high powered aluminum former, using copper shorting ring and oversized magnet for lower distortion.
Tweeter	26mm (1") dual concentric diaphragm with wave-guide centre plug for controlled directivity. Non-reflective dual chambered magnet structure with copper shorting ring to lower distortion.
Crossover Point	340Hz & 2.5kHz
Impedance	Nominally 4 ohms
Enclosure Type	Triple chambers – sealed midrange chamber, with dual bass reflex chambers, front vented.
Dimensions	box: 1700mm high x 390mm wide x 80mm deep front baffle: 962mm high x 225mm wide x 18mm deep
Material	12mm MDF enclosure, 25mm braces, with 18mm MDF front baffle
Finish	Black Suede Vinyl
Volume	34 litres internal
Weight	27kg each

### warranty

5 year warranty applies to the cabinet and speaker.

*(Refer to the details on the warranty card supplied)*

### queries

If you have any queries regarding the Epix setup procedure or any other Krix product, please contact your nearest Krix retailer or Krix directly. Contact details are on the back cover of this booklet.

Krix Loudspeakers Pty Ltd  
14 Chapman Road  
Hackham SA 5163  
Australia

T 61 8 8384 3433  
F 61 8 8384 3419  
listen@krix.com

Rev #10003

[krix.com](http://krix.com)