



On-Wall Set with Audio
Mx-M-OWA-AU / Mx-M-OWA-AU-b

Vandalism Set
for On-Wall Set with Audio
MX-MT-v25-V-XL

On-Wall Set with Audio for MOBOTIX v26

For on-wall installation of MOBOTIX camera v26 (not included), for ceiling or upright installation, includes microphone and speaker.

More information:
www.mobotix.com > Products > Accessories > Mounting > v26 On-Wall Set with Audio

Mx-M-OWA-AU
32.942-001_EN_06/2017

MOBOTIX

Standard Delivery



Item	Count	Part Name
1.1	1	On-Wall Set with Audio housing
1.2	1	Threaded plug (installed, black or white – depending on housing color)
1.3	2	Cable fitting (1 white, 1 black)
1.4	1	Sealing disc
1.5	1	Speaker with cable and connector (installed)
1.6	1	Microphone with cable and connector
1.7	1	Sealing for microphone, blue
1.8	4	Washer 5.3 mm dia., stainless steel
1.9	4	Cylinder head screw M5 x 12 mm, stainless steel
1.10	1	Allen wrench 3 mm
1.11	1	Torx wrench TX6

Preparing the Camera

1. Remove the dome

Unscrew the dome using a lint-free cotton cloth.

2. Install the microphone in the camera housing

Push the microphone into the blue sealing as shown.

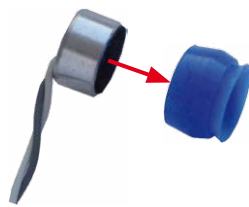

Insert the microphone into the chamber on the back of the camera housing. Use a small, nonconductor rod (wood, cardboard, plastic) and press the microphone carefully down into the housing until it stops.



3. Connect the microphone cable

Guide the microphone cable from the back through the center of the camera housing as shown. Connect the cable by pushing the cable connector into the socket labeled "MIC" next to the SD card (red arrow in figure on the right).

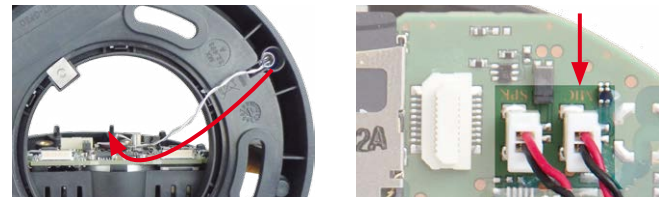

4. Complete optional tasks

You can now complete the following tasks as shown in the camera documentation:

- Exchange the supplied microSD by a card with more storage capacity.

Preparing the On-Wall Set with Audio

1. Install the Cable Fitting (Optional)

If you are running the cables from the side and not from the rear, you should exchange the threaded plug against the supplied cable fitting. To unscrew the threaded plug, use a suitable coin.



2. Install the Interface Box Boards (Optional)

You can install the boards of up to two interface boxes inside the on-wall set. First, remove the lid of the interface box (three screws). Remove the two screws (red arrows in figure) using the supplied Torx wrench TX6 (Pos. 1.11) and remove the board.

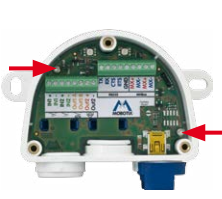

Properly fasten the interface box boards using the same screws and the Torx wrench at the corresponding positions within the housing of the on-wall set.

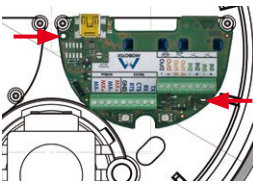

3. Prepare the Installation of the On-Wall Set

Make sure that there is enough space for installing the On-Wall Set with Audio and that you can access it from the rear or the side later on. The surface should be even and smooth so that the sealing lies flat properly.

Drill the holes using the drilling template on the back of this document and insert the supplied dowels, if required.

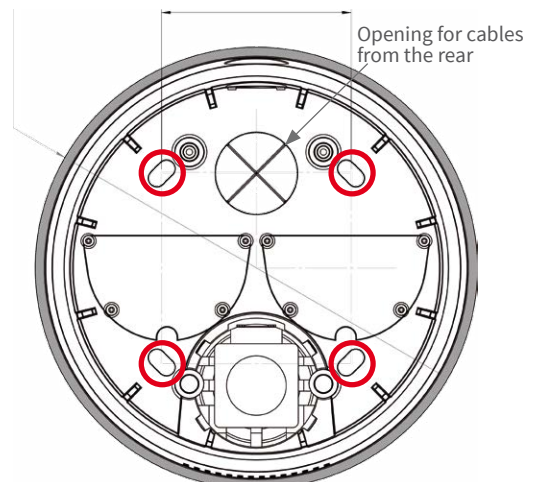

Guide the cables from the back (through the sealing disc of the on-wall set) or from the side. When guiding the cables from the back into the set, you need to cut the sealing disc as shown using a sharp knife (marked by a red cross in figure at the right). Only cut so far as to allow all cables and wires to pass.



Installing the On-Wall Set with Audio

1. Install the On-Wall Socket

- Place the sealing onto the rear of the on-wall socket as shown. Make sure that the area marked in blue covers the speaker and that the drilled holes correspond to the holes in the sealing (red arrows in figure).
- If required, lead the cables from the rear through the sealing and the on-wall socket.



- Hold the on-wall socket and the sealing over the holes and attach the on-wall socket using the Torx screws with washers 5.3 mm dia. **supplied with the camera** (red arrows at the right).



2. Connect the Interface Box Boards

- If you are using interface boxes, connect the corresponding wires to the boards.
- Note:** Please follow the notes on installing in the documentation of the individual interface box.

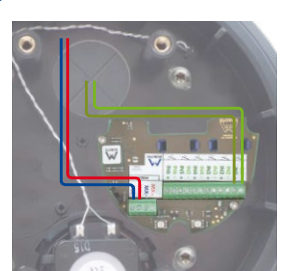

3. Apply the Camera Sealing Disc

- Lead the connected cables (Ethernet, speaker, MxBus, etc.) from the rear through the camera sealing disc.
- Place the sealing disc with the cables onto the on-wall set as shown. Make sure that the threaded inserts of the on-wall set (marked red in the figure) are showing through the sealing.



MOBOTIX

1. Connect the Speaker Cable

Roughly point the camera into the proper viewing direction, lead the speaker cable (together with any other cables) from the back into the camera and push the cable connector into the socket labeled “SPK” next to the SD card (red arrows in figures below).

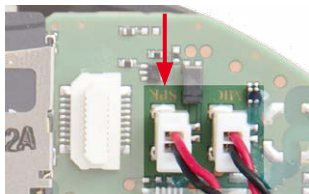

2. Mount the v26 on the On-Wall Set with Audio

- Place the camera onto the On-Wall Set with Audio in such a way that the microphone is opposite to the speaker of the on-wall set.
- Use the four supplied cylinder head screws M5 x 12 mm (item 1.9) and 5.3 mm dia. washers (item 1.8) to affix the camera on the On-Wall Set with Audio (red circles in figure at the right).



3. Further Tasks

You can now complete the remaining tasks as described in the camera documentation («Quick Install Indoor Dome v26»):

- Installation of MX-Bus-IO-Module (if supported by the camera)
- Complete the cabling (Ethernet, MxBus (if supported by the camera), wires for inputs/outputs)
- Insert the reflection protection (ring only)
- Adjusting the camera
- Operating the camera

Safety Warnings

- This product must not be used in locations exposed to the dangers of explosion.
- The On-Wall Set with Audio is only to be used in combination with MOBOTIX cameras of the v26 series.
- Make sure that you install this product as outlined in the installation instructions above.
- Electrical systems and equipment may only be installed, modified and maintained by a qualified electrician or under the direction and supervision of a qualified electrician in accordance with the applicable electrical guidelines. Make sure to properly set up all electrical connections.
- Only install this product in or on suitable, solid materials that provide for a sturdy installation of the fixing elements used.
- When using a MOBOTIX interface box (e.g., MX-232-IO-Box), the installation instructions of these boxes are also to be followed.
- For the On-Wall Set with Audio, the same operating conditions apply as for the installed MOBOTIX camera.

Technical Specifications

On-Wall Set with Audio	
Dimensions	Total diameter (with sealing disc) 163.4 mm/6.43 in, height without camera: 32.5 mm/1.28 in, with bars 38.5 mm/1.52 in, height with v26: 121 mm/4.76 in
Operating Conditions	Same as for installed MOBOTIX camera
Materials	Housing: PBT GF30
Weight	254 g (with sealing disc)

Dimensions with Installed Camera

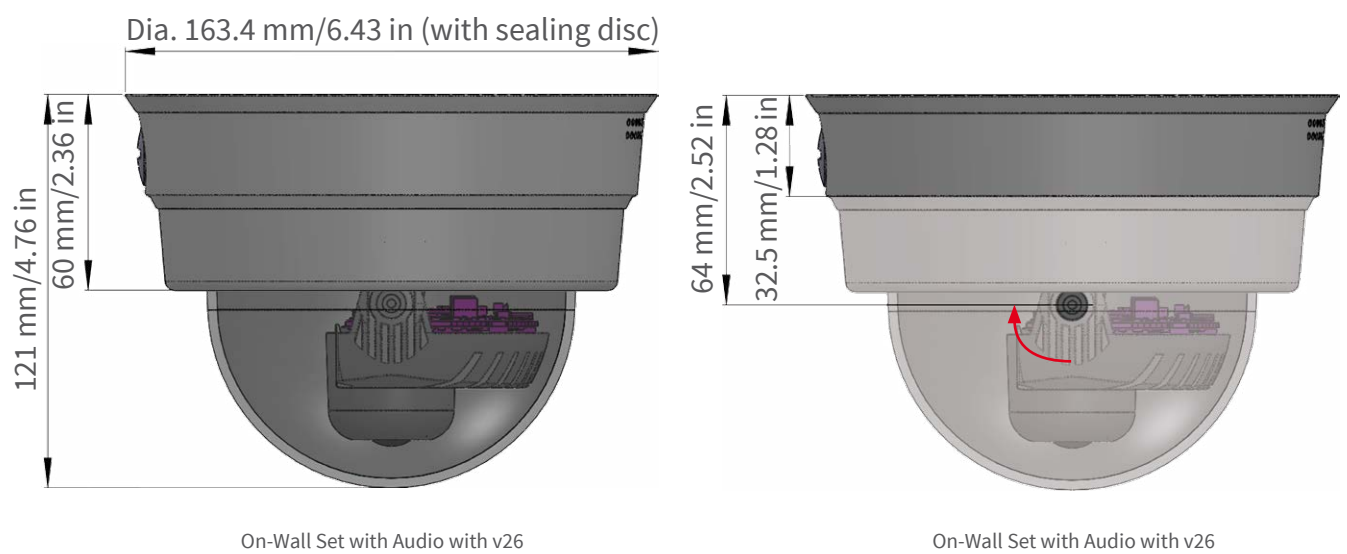

Dimensions/Drilling Template

