

CLIPSAL[®]

by Schneider Electric

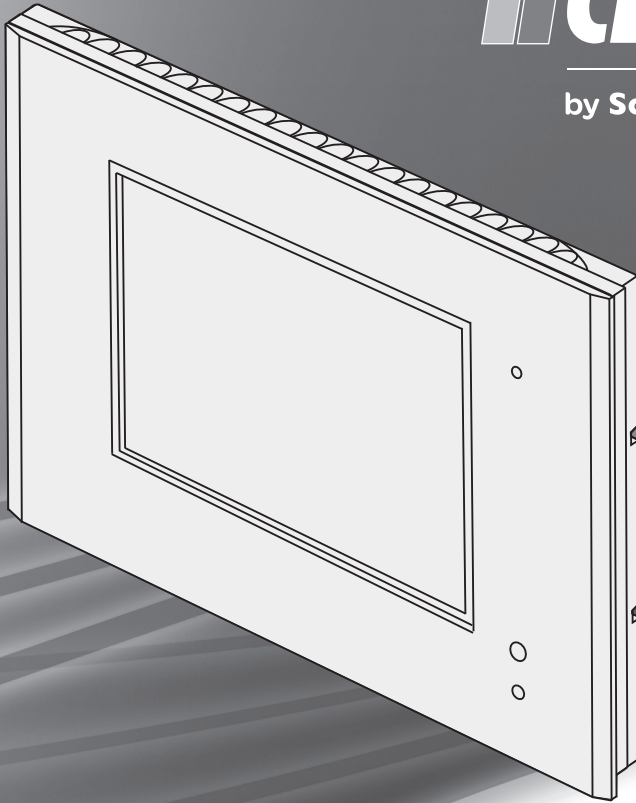

C-Bus[®]

Colour Touchscreen

5000CTC3 Series



User's Guide

Contents

1.0	Product Description	3
2.0	Capabilities	5
3.0	Using the Touchscreen	6
	3.1 Typical Page for Controlling Appliances	7
	3.2 Configuration Page	8
4.0	Remote Control	9
5.0	Scenes	10
6.0	Schedules	10
7.0	Care Instructions	11
8.0	Removing and Installing the Fascia	11
9.0	Specifications	13
10.0	Two-Year Warranty	14
11.0	Installer Details	15

Copyright 2011. Schneider Electric Australia Pty Ltd. All rights reserved.

The information in this document is provided in good faith. Schneider Electric Australia Pty Ltd has endeavoured to ensure the relevance and accuracy of the information, but assumes no responsibility for any loss incurred as a result of its use. Schneider Electric does not warrant that the information is fit for any particular purpose, nor does it endorse its use in applications that are critical to the health or life of any human being. Schneider Electric reserves the right to update the information at any time without notice.

C-Bus, Clipsal, C-Touch and HomeGate are trademarks of Schneider Electric Industries SAS. All other trademarks are the property of their respective owners.

November 2011

1.0 Product Description

The colour touchscreen is a configurable controller and scheduler for C-Bus systems. It has infrared remote capability and a backlit colour display touchscreen. The unit mounts in a wall and connects to the C-Bus network, providing control and scheduling of services throughout a home or commercial installation.

The touchscreen displays a series of touch-sensitive pages that are associated with various lights or other electrical devices on the C-Bus network. You can use the unit to trigger 'scenes' where multiple devices are switched on together, setting a particular mood at the press of a button. You can also control appliances according to a schedule.

The colour touchscreen is a wall-mounted unit available with several fascia styles and colours (see Table 1). The colour touchscreen includes an IR window for remote control interface functions using a hand held C-Bus remote control.

Catalogue Number	Description
5080CTC3-xx	Colour touchscreen, 6.4", wall mount, beveled glass surround. Several fascia colour options are available.
5050CTC3-xx	Colour touchscreen, 6.4", wall mount, Neo style plastic fascia. Several fascia colour options are available.
	Parts package, including: stylus, microfibre cleaning cloth, ferrite filter, WiFi antenna and extension, mounting screws and a programming cable. (included parts)
5035TX2	C-Bus infrared remote control, 5-button
	Power supply, 24V d.c., 1.25A, 30W, with AC adapters and screw terminal adapter (power supply ordered separately)

Table 1. Colour touchscreen and accessories

An infrared remote control is provided with the touchscreen for local control. When connected to a Clipsal StarServe™ system, the touchscreen can be controlled from any location where an infrared target is located.

To program the touchscreen, a PC is connected to the LAN interface located behind the fascia. Clipsal Toolkit and Piced configuration software tools are downloaded from the Web. Projects are created using Piced and are transferred to the touchscreen's memory. The appearance of every touchscreen's setup is unique, so your display may look different from examples in this guide.

An internal battery maintains the time and date settings. The touchscreen's processor automatically controls the contrast and brightness of the screen as well as backlight level control.

By setting access levels and passwords, you can set up the touchscreen to restrict access to touchscreen functions.

Figure 1 shows the features of the front side of the unit. Normally, you do not need to remove the front fascia. It must be removed to gain access to the reset button. See the instructions later in this guide for removing and installing the fascia.

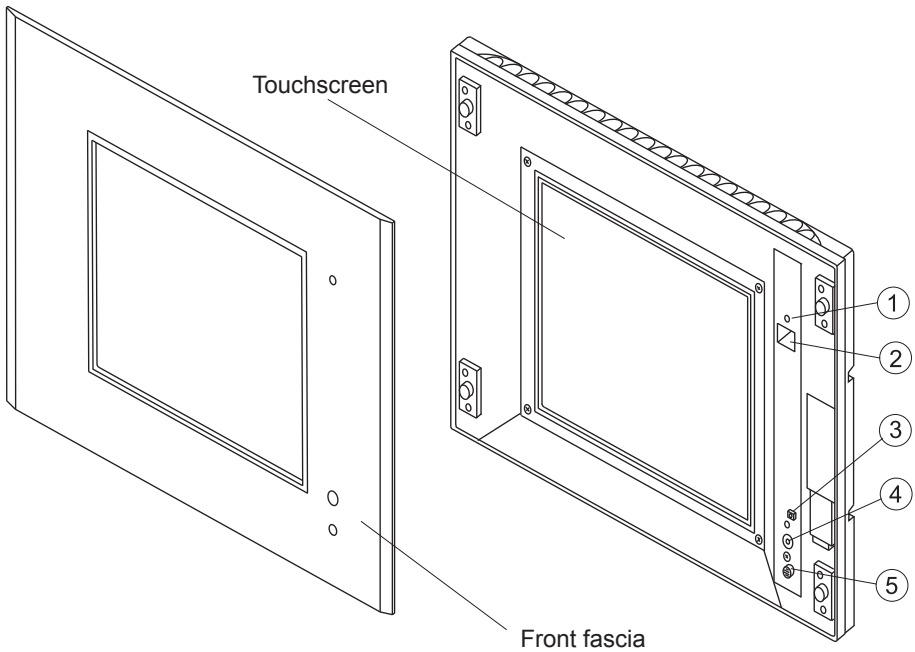

Figure 1. Front panel features

Figure reference	Description
1	Power on/off indicator LED
2	Programming connector (RJ45)
3	Reset pushbutton
4	Infrared remote control window
5	Light level sensor

2.0 Capabilities

Depending on its configuration, you can use the touchscreen to:

- switch and dim lights and other electric appliances
- switch off lights and appliances using a timer
- automatically control lights and appliances using a schedule
- simultaneously control multiple appliances from a single button (using scenes)
- activate the colour touchscreen functions by remote control
- monitor a room or other area with an IP camera
- view HTML-compatible pages over a network

A typical touchscreen page is shown in Figure 2. Notice that the page allows you to turn lights and security on an off and to activate scenes.

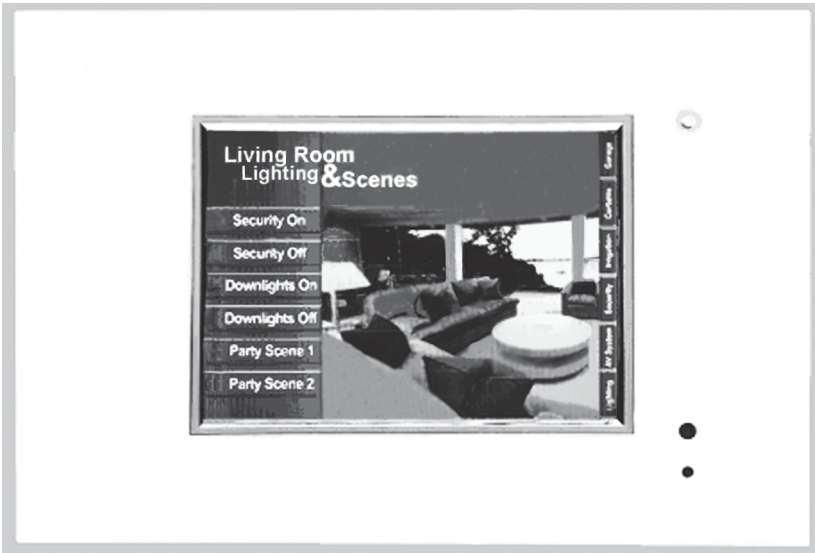

Figure 2. Typical touchscreen page for control of lighting, security and scenes

3.0 Using the Touchscreen

The colour touchscreen is configured with software customised for a particular location (such as your home or office). The software typically presents a main page with buttons that link to other pages.

Most pages contain buttons that control appliances such as lights, fans, and curtains. Some pages contain slider controls or radio buttons that adjust lighting levels or select from a range of options. Pages can also display local or networked HTML documents, or a video feed from an IP camera as shown in Figure 3.

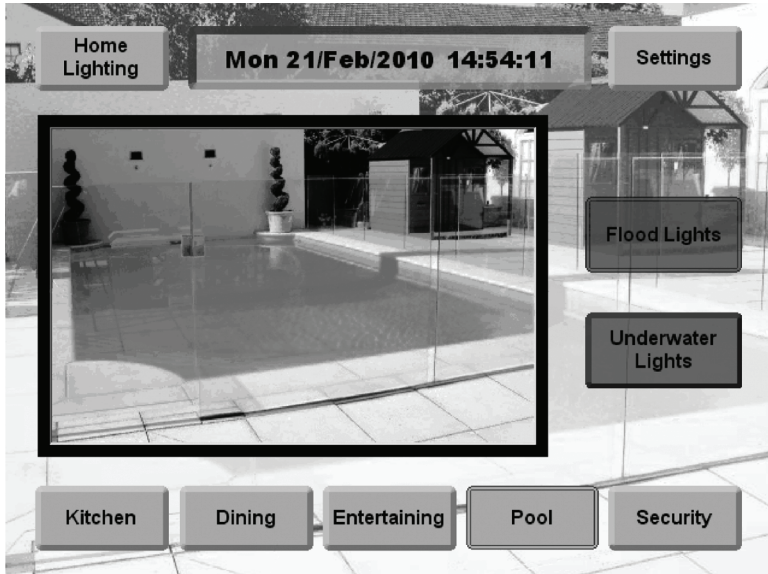

Figure 3. A page that displays video from an IP camera

Definitions

Term	Definition
load	An electrical device (such as a light) connected to a C-Bus output unit (such as a dimmer).
scene	A series of actions across multiple outputs, triggered by a single button. For example, on arrival home, you could use a scene to switch on lights in the hallway, kitchen and lounge, and switch on a heater.
schedule	A sequence of events set to occur at particular times in the future.
backlight	The light behind the LCD screen providing visibility in varying lighting conditions.

3.1 Typical Page for Controlling Appliances

Figure 4 shows an example of a page that is used to control lights and fans in a kitchen. The page includes:

- **Scene** buttons that set appliances to specific levels. For example, the Cooking button sets the kitchen and bench lights to their highest levels and switches the exhaust and range hood fans on.
- **Switch** buttons that allow you to toggle appliances on and off.
- **Sliders** that allow you to adjust (dim) specific lighting levels, by touching the slider with your finger and dragging up or down.
- **Buttons** that link to other pages.

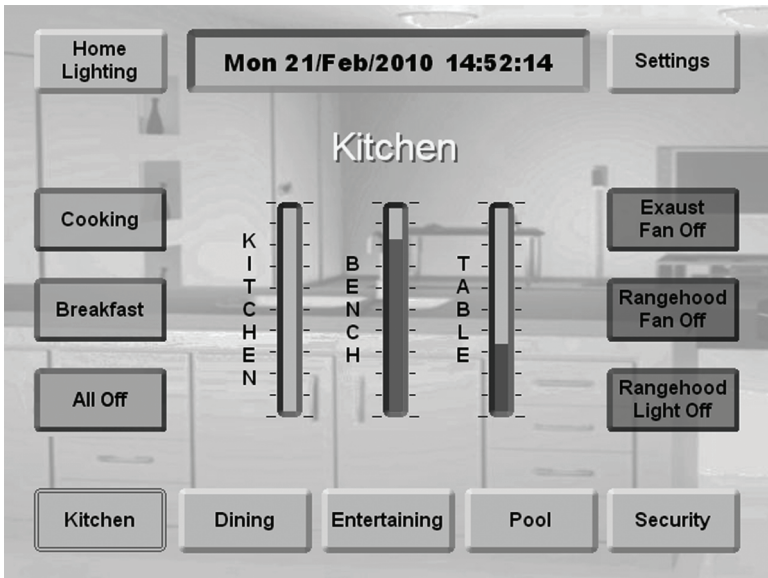

Figure 4. A page used to control kitchen lights and fans

3.2 Configuration Page

The touchscreen's software includes a configuration page, such as the one shown in Figure 5. This page allows you to customise your unit. The configuration page may have a different name, such as Tools, Utilities, Setup, Settings or System.

Depending on your installation, the configuration page may allow you to:

- set or change the time and date
- change the region or language
- temporarily ignore screen presses (cleaning mode)
- adjust sound settings
- adjust the backlight
- set or change a password
- calibrate the screen
- configure the unit's network settings

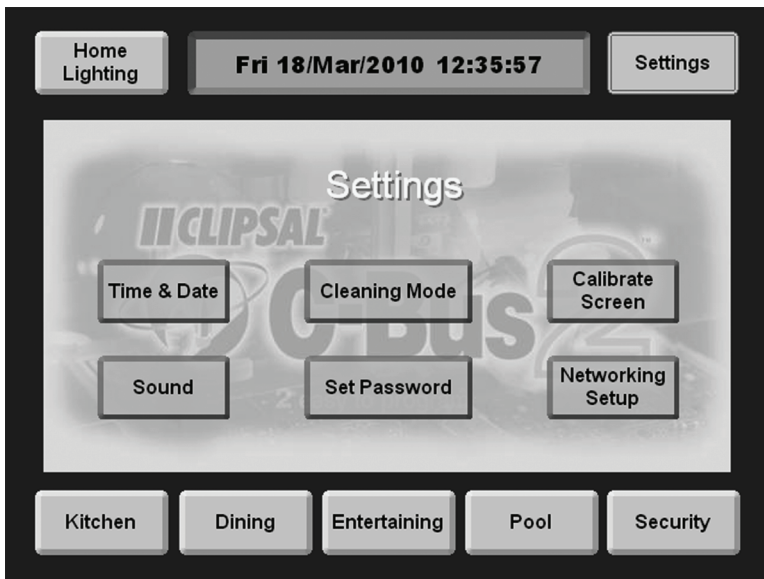

Figure 5. An example of a configuration (settings) page

4.0 Remote Control

The colour touchscreen is supplied with an infrared remote control that allows you to control appliances from a distance. You can use the remote to trigger scenes, switch appliances and adjust lighting levels, depending on how the touchscreen was configured by the installer.

If you have multiple touchscreen units (colour or black & white), you can use the same remote control for all of them. The remote has a range of approximately 8 metres from the infrared receiver at 90° to the touchscreen, or 4 metres at 60°. This is illustrated in Figure 6. A universal remote control with learning capability (such as the Clipsal 5030URC) can be used to control C-Bus touchscreens. Please follow the instructions of the learning remote control.

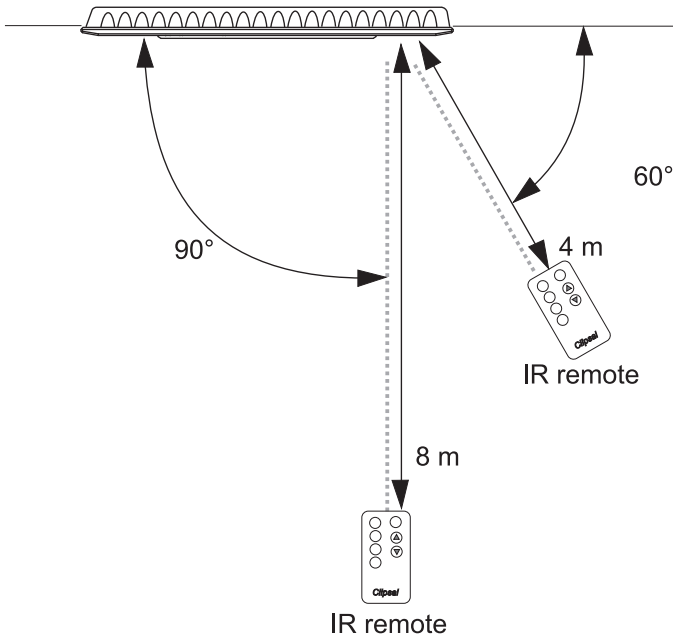

Figure 6. Remote control range

The infrared remote control is supplied with a CR2025 (or equivalent) coin type lithium battery. The battery is shown in Figure 7.

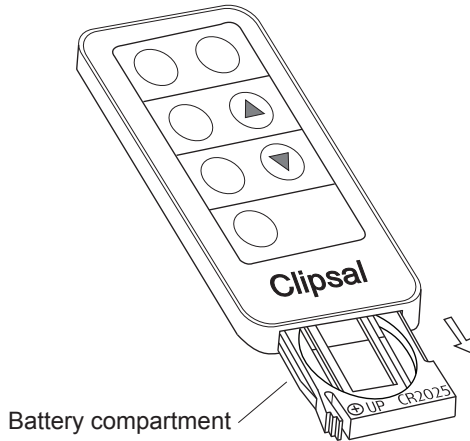

Figure 7. Battery compartment in the 5035TX2 remote control

5.0 Scenes

One of the benefits of an automation system is the combining of events to create a special effect or mood. An example of this is when a movie starts at a cinema. The house lights dim, the curtains open and the movie begins to play. You can reproduce this effect by creating a scene triggered by your touchscreen unit.

Almost anything on your C-Bus system can be included in a scene. Ask your installer for information on how scenes can be used to set special moods.

6.0 Schedules

A schedule is used to make something happen at a particular time. Since this feature is included in the touchscreen, you can ask your installer to include schedules that perform household chores on a regular basis. An example would be to turn the lights on and off when you are away from home to make the house look lived in. You can create the impression that someone is home and moving from room to room a various times. Another example is something often forgotten, such as watering the garden on a regular basis.

Note: Your installer creates schedules using special software tools.

7.0 Care Instructions

The touchscreen unit contains electrical and electronic parts. Follow these guidelines to maintain the unit:

- Clean the touchscreen regularly using the soft cleaning cloth provided.
- Do not use chemicals or spray cleaners on the touchscreen or the fascia.
- Do not operate the unit with wet hands.
- Do not use hard, sharp objects to select the controls. Use your fingertip or the provided stylus.
- Allow adequate ventilation. Do not block the ventilation holes.

Note: The warm airflow coming from the vents on the top of the unit may cause discolouration of some surfaces over time.

8.0 Removing and Installing the Fascia

Normally, you do not need to remove the fascia. You might be instructed to access the reset button that is located behind the front fascia. Do not leave the touchscreen unit unattended when the fascia is removed.

To remove the fascia refer to the figure and follow these steps:

- 1) Grasp the right side of the fascia with your left hand.
- 2) Push the release lock in with your right thumb. At the same time lift the right side of the fascia plate off and to the right with your left hand.
- 3) Swing the fascia off towards the left. Refer to Figure 8.

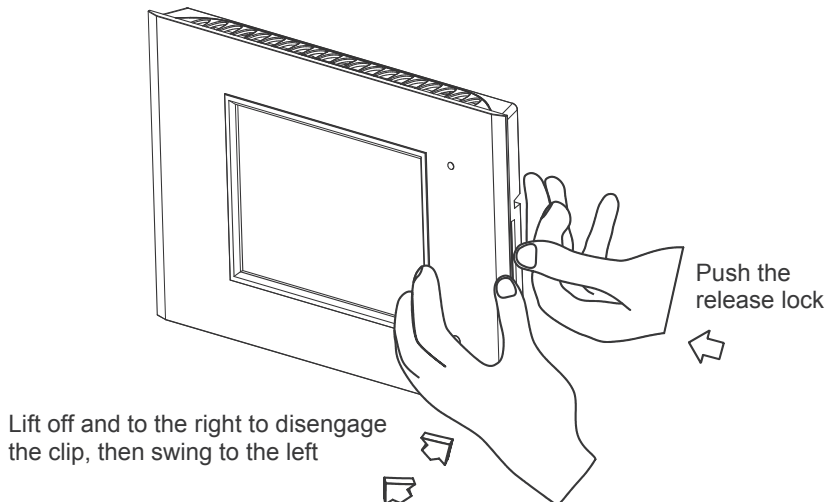
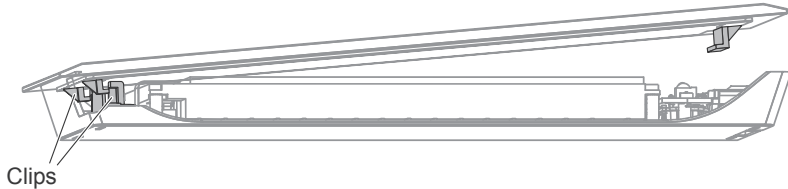

Figure 8. Removing the fascia

To install the fascia, do the following:

1. Position the fascia over the touchscreen, with the IR and indicator windows on the right hand side. Ensure that the clips on the left underside of the fascia are positioned slightly to the left of the matching clips on the touchscreen.



2. While applying forward pressure on the left side of the fascia (toward the touchscreen), push the left side to the right. You should feel the clips slot into each other.



3. Push the right side of the fascia forward and to the right until the clip on the underside snaps into place.

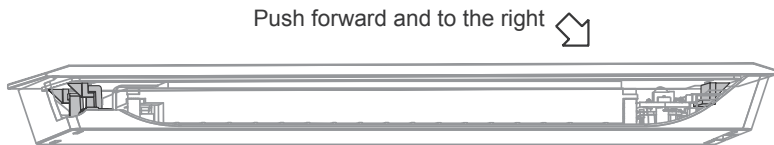

9.0 Specifications

Parameter	Description
Supply voltage	12 - 36V d.c., class 2
Display type	16.3cm (6.4 in) TFT Colour Active Matrix LCD
Display resolution	640 × 480 pixels
Display luminance	> 300cd/m ² Controlled by the processor
Display contrast ratio	> 100:1
Viewing angle	left, right: 60°; down: 55°; up: 40°
Backlight lifetime (typical)	50,000 hours
Touch surface durability	35 million touches in any one location, 1 million slide touches
C-Bus supply voltage	15 to 36V d.c. @ 20mA required for normal operation. Does not provide current for the C-Bus network.
C-Bus control functions	Load switching and dimming, control and scheduling
C-Bus connection	2 × C-Bus RJ45 (parallel)
C-Bus System Clock	Software selectable
Connections	USB type A x 2 Ethernet, RJ45 x 2, one front, one back RS-232, DB9 Audio Line In, 3.5mm stereo Audio Line Out, 3.5mm stereo Infrared In, 3.5mm mono Keyboard, PS/2 Power, 2 pin screw terminal
Operating temperature range	XX to XX°C (XX to XX °F)
Operating humidity range	5 to 90% RH (non-condensing)
Weight	1375 g (excluding fascia)

10.0 Two-Year Warranty

The 5000CTC3 Series Colour Touchscreen carries a two-year warranty against manufacturing defects.

Warranty Statement

The benefits conferred herein are in addition to, and in no way shall be deemed to derogate, either expressly or by implication, any or all other rights and remedies in respect to the Clipsal by Schneider Electric product, that the consumer has in the location where the product is sold.

The warrantor is Schneider Electric (Australia) Pty Ltd, a member of Schneider Electric Industries SAS, with offices worldwide.

This Clipsal by Schneider Electric product is guaranteed against faulty workmanship and materials for a period of two(2) years from the date of purchase.

Schneider Electric (Australia) Pty Ltd reserves the right, at its discretion, to either repair free of parts and labour charges, replace or offer refund in respect to any article found to be faulty due to materials, parts or workmanship.

This warranty is expressly subject to the Clipsal by Schneider Electric product being installed, wired, tested, operated and used in accordance with the manufacturer's instructions. Any alterations or modifications made to the product without permission of Schneider Electric (Australia) Pty LTD might void the warranty.

Schneider Electric (Australia) Pty Ltd shall meet all costs of a claim. However, should the product that is the subject of the claim be found to be in good working order, all such costs shall be met by the claimant.

When making a claim, the consumer shall forward the Clipsal by Schneider Electric product to the nearest Clipsal by Schneider Electric office. Provide adequate particulars of the defect within 28 days of the fault occurring. The product should be returned securely packed, complete with details of the date and place of purchase, description of the load and circumstances of the malfunction.

For all warranty enquiries, contact your local Clipsal by Schneider Electric sales office. The address and contact number can be found at the website

<http://www.clipsal.com/locations>

or by telephoning 1 300 722 247, the CIS Technical Support Hotline (Australia only).

11.0 Installer Details

Parameter	Description
Name	
Company	
Address	
City / Suburb	
State	
Postcode / Zipcode	
Country	
Voice Phone	
Mobile Phone	
Facsimile	
Email	
Web	

Technical Support and Troubleshooting

For further assistance in using this product, consult your nearest Clipsal by Schneider Electric Sales or Technical Support Office.

Australia Technical Support Hotline 1300 722 247

New Zealand Technical Support Hotline 0800 888 219

United States Customer Information Center 1 888 778 2733

lightingcontrol.support@us.schneider-electric.com

CIS Technical Support email: cis.support@clipsal.com.au



Schneider Electric (Australia) Pty Ltd

clipsal.com

Contact us: clipsal.com/feedback

National Customer Service Enquiries

Tel 1300 2025 25

Fax 1300 2025 56

Schneider Electric (Australia) Pty Ltd reserves the right to change specifications, modify designs and discontinue items without incurring obligation and while every effort is made to ensure that descriptions, specifications and other information in this instruction manual is correct, no warranty is given in respect thereof and the company shall not be liable for any error therein.

© 2011 Schneider Electric. All rights reserved.
Trademarks are owned by Schneider Electric Industries SAS or its affiliated companies.